

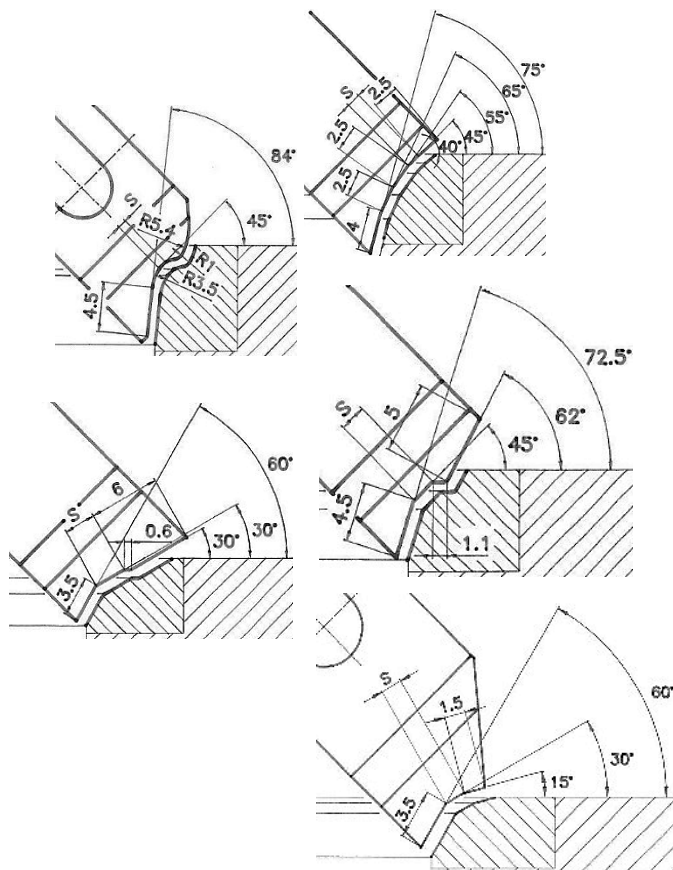

**MIRA**®

**Formtools and Pilots**  
**Formstähle und**  
**Führungsdorne**  
***Outils de façon et pilotes***  
***Skärstal och Styrspindlar***  
**Utensili e pilote**  
***Cuchillas y pilotos***



**Summary****Inhaltsverzeichnis****Table des matières**

1	Introduction .....	4
1	Einleitung .....	4
1	<i>Introduction</i> .....	4
2	Formtools and lettering of Formtools .....	5
2	Formstähle .....	5
2	<i>Outils de façon</i> .....	5
2	<i>Skärstål</i> .....	5
2	Utensil ad angolazione multipla .....	5
2	<i>Cuchillas de mandrinado moldeada</i> .....	5
3	Lettering of Formtools .....	5
3	Beschriftung der Formstähle.....	5
3	<i>Inscription des outils de façon</i> .....	5
3	<i>Märkning av Skärsål</i> .....	5
3	Dicitura degli utensili ad angolazione multipla.....	5
3	<i>Denominación de las cuchillas de mandrinado moldeadas</i> .....	5
4	Order Form for Mira Formtools.....	6
4	Bestellformular für Mira-Formstähle .....	6
4	<i>Bulletin de commande pour outils Mira</i> .....	6
5	Tool-heads and types of formtools .....	7
5	Drehköpfe und Formstahltypen .....	7
5	<i>Têtes porte-outils et modèles d'outils</i> .....	7
5	<i>Skärhuvuden och Skärstålmodeller</i> .....	7
5	Teste porta-utensili e Tipi d'utensili.....	7
5	<i>Cabezales mandinadores y Modeles de cuchilla</i> .....	7
6	Pilots .....	8

6	Führungsdorne .....	8
6	<i>Pilotes</i> .....	8
6	<i>Styrspindlar</i> .....	8
6	Piloti .....	8
6	<i>Pilotos</i> .....	8
7	mira formtool list .....	9
7	mira Formstahlliste .....	9
7	<i>mira list des outils de façon</i> .....	9
8	Standard Formtool 45° .....	16
8	Standard-Formstähle 45° .....	16
8	<i>Outils de façon standard 45°</i> .....	16
8	<i>Standard skärstål 45°</i> .....	16
8	Utensili ad angolazione multipla standard 45° .....	16
8	<i>Cuchillas de mandrinado moldeada standard 45°</i> .....	16
9	Formtools 45° .....	17
9	Formstäle 45° .....	17
9	<i>Outils de façon 45°</i> .....	17
9	<i>Skärstål 45°</i> .....	17
9	Utensili ad angolazione multipla 45° .....	17
9	<i>Cuchillas de mandrinado moldeada 45°</i> .....	17
10	Standard Formtool 30° .....	26
10	Standard-Formstähle 30° .....	26
10	<i>Outils de façon standard 30°</i> .....	26
10	<i>Standard skärstål 30°</i> .....	26
10	Utensili ad angolazione multipla standard 30° .....	26
10	<i>Cuchillas de mandrinado moldeada standard 30°</i> .....	26
11	Formtools 30° .....	27
11	Formstähle 30° .....	27

11	<i>Outils de façon 30°</i> .....	27
11	<i>Skärstål 30°</i> .....	27
11	Utensili ad angolazione multipla 30° .....	27
11	<i>Cuchillas de mandrinado moldeada 30°</i> .....	27
12	Formtools 20° .....	30
12	Formstähle 20° .....	30
12	<i>Outils de façon 20°</i> .....	30
12	<i>Skärstål 20°</i> .....	30
12	Utensili ad angolazione multipla 20° .....	30
12	<i>Cuchillas de mandrinado moldeada 20°</i> .....	30
13	Formtools 35°/ 38° .....	31
13	Formstähle 35°/ 38° .....	31
13	<i>Outils de façon 35°/ 38°</i> .....	31
13	<i>Skärstål 35°/ 38°</i> .....	31
13	Utensili ad angolazione multipla 35°/ 38° .....	31
13	<i>Cuchillas de mandrinado moldeada 35°/ 38°</i> .....	31
14	Formtools for corrections .....	32
14	Formstähle für Korrekturen .....	32
14	<i>Outils de façon pour dégagements</i> .....	32
14	<i>Skärstål för reducering</i> .....	32
14	Utensili ad angolazione multipla per correzioni .....	32
14	<i>Buriles para correcciones</i> .....	32
15	Formtools for corrections and counterbores .....	33
15	Formstähle für Korrekturen und Ringsitze .....	33
15	<i>Outils de façon pour dégagements et l'usinage de logements</i> .....	33
15	<i>Skärstål för reducering och ringsäten</i> .....	33
15	Utensili ad angolazione multipla per correzioni e per anelli .....	33
15	<i>Buriles para correcciones y anillos de asiento</i> .....	33

## 1 Introduction

Thanks to their profiled carbide tip, **mira** formtools allow a quick processing of the entire valve seat profile in one working cycle. **mira** offers you the largest range of formtools in various shapes, with seat widths from 0.5 to 8.0 mm and seat angles of 45° and 30°, in two qualities ("normal" and "X" for extremely hard valve seats) and with 4 different holder types.

All formtools which are available from stock are listed in this catalogue.

The respective drawings of formtools are shown on pages 16 - 33, assorted by seat angle and seat width.

**mira** can also offer special priced custom made formtools on request. Orders for special formtools may be placed by filling-in the order form included in this catalogue. You will find the required information in the corresponding vehical manual. Any missing information must be established from the appropriate cylinder head or are available with the general dealer.

To determine the size of holder, please consider the valve seat diameter and the different types of tool-heads (refer to the following pages).

## 1 Einleitung

**mira** Formstähle ermöglichen dank ihrer profilierten Hartmetallschneide eine schnelle Bearbeitung des gesamten Ventilsitzprofils in einem Arbeitsgang. **mira** bietet Ihnen das grösste Sortiment an Formstählen in verschiedenen Formen, mit Sitzbreiten von 0.5 - 8.0 mm, Sitzwinkel von 45° und 30° und zwei Qualitäten ("normal" und "X" für besonders harte Ventilsitze) sowie mit 4 verschiedenen Haltertypen.

Alle ab Lager erhältlichen Formstähle sind in diesem Katalog aufgelistet.

Die entsprechende Formstahl-Zeichnung finden Sie auf den Seiten 16 - 33, sortiert nach Sitzwinkel und Sitzbreite.

Nebst diesen Formstählen sind auf Anfrage auch Spezialformstähle erhältlich, welche zu einem Spezialpreis hergestellt werden. Für Bestellungen von Spezialanfertigungen füllen Sie bitte das Bestellformular in diesem Katalog aus. Die benötigten Daten finden Sie im Handbuch des entsprechenden Fahrzeuges. Fehlende Angaben sind bei Ihrem Generalimporteur erhältlich oder müssen am Zylinderkopf ausgemessen werden.

Für die Bestimmung des Halter-Typs sind der Ventilsitzdurchmesser sowie die verschiedenen Drehkopftypen zu berücksichtigen (siehe folgende Seiten).

## 1 Introduction

*Grâce à leur lame profilée en métal dur, les outils de façonnage **mira** permettent l'usinage rapide des sièges de soupape, en une seule passe. **mira** vous propose un immense assortiment d'outils de façonnage de diverses formes, avec des largeurs de siège de 0.5 à 8.0 mm et des angles de siège de 45° ou 30°, en deux Qualités ("normale" et "X", pour les sièges de soupape particulièrement durs), et avec 4 divers types de support.*

*Tous les outils de façonnage disponibles sur stock sont énumérés dans le présent catalogue.*

*Vous trouverez les dessins correspondants aux pages 16 à 33, classés selon les angles et les largeurs de siège.*

*Outre les outils ci-dessus, des outils de façonnage spéciaux, fabriqué à des prix eux aussi spéciaux, sont disponibles sur demande. Pour la commande de versions spéciales, nous vous prions de remplir le formulaire inclus dans ce catalogue. Vous trouverez les données nécessaires dans le manuel de véhicule correspondant. Les données manquantes seront disponibles auprès de votre importateur général, ou bien vous devrez les mesurer sur la culasse.*

*Pour déterminer le type de support, il faudra tenir compte de diamètre de sièges de soupape ainsi que des divers types de têtes tournantes (voir les pages suivantes).*

**2 Formtools and lettering of Formtools**

**2 Formstähle**

**2 Outils de façon**

**2 Skärstål**

**2 Utensil ad angolazione multipla**

**2 Cuchillas de mandrinado moldeada**

$\alpha$   
Seat angle  
Sitzwinkel  
Angle de siège  
Sätessvinkel  
Angolo di sede  
Ángulo del asiento

$\beta$   
Lower correction angle  
Unterer Korrekturwinkel  
Angle de dégage-  
ment inférieur  
Inre korrek-tionsvinkel  
Angolo di correzione inferiore

$\gamma$   
Upper correction angle  
Oberer Korrekturwinkel  
Angle de dégage-  
ment supérieur  
Yttre korrek-tionsvinkel  
Angolo di correzione superiore

**S**  
Seat width  
Sitzbreite  
Largeur de siège  
Sätessbredd  
Larghezza di sede  
Largura del'

**LC**  
Lower correction length  
Unterer Korrekturlänge  
Largeur du dégage-  
ment inférieure  
Inre korrek-tionsbredd  
Larghezza di correzione infe  
Largura de la corrección infe

**UC**  
Upper correction length  
Obere Korrekturlänge  
Largeur du dégage-  
ment sup  
Yttre korrek-tionsbredd  
Larghezza della correzione s  
Largura de la corrección sup

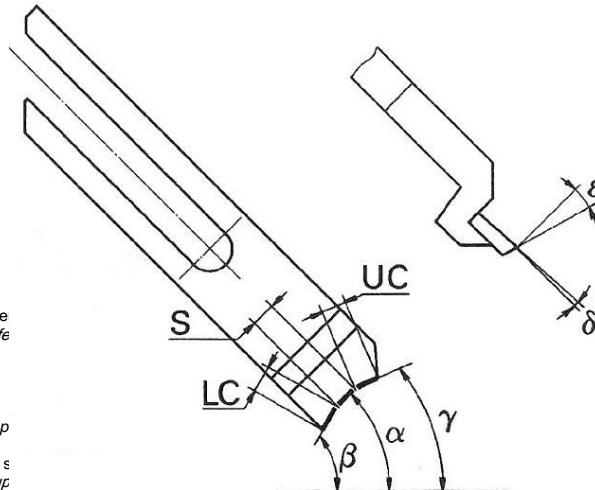

$\epsilon$  Typ A+B+DT=10°; Typ C=15°  
Clearance angle  
Freiwinkel  
Dépouille  
Släppingsvinkel  
Angolo di spoglia inferiore  
Despajo

$\delta=3^\circ$   
Cutting angle  
Schnittwinkel  
Angle de coupe  
Skärwinkel  
Angolo di spoglia  
anteriore

**3 Lettering of Formtools**

**3 Beschriftung der Formstähle**

**3 Inscription des outils de façon**

**3 Märkning av Skärsål**

**3 Dicitura degli utensili ad angolazione multipla**

**3 Denominación de las cuchillas de mandrinado moldeadas**

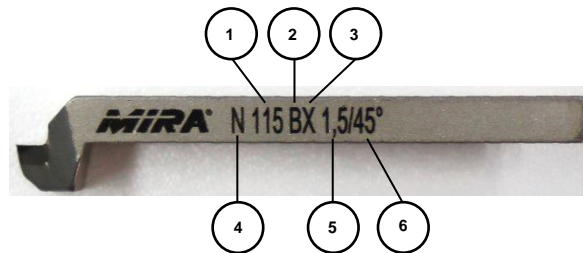

1	Formtool No.	Formstahlnummer	Nombre d'outil	Skärstålnummer	Numero del l' utensile	Número de la cuchilla
2	Formtool model A – normal diameter B – bigger diameter C – only little diameter DT – only DT3 tool-head for biggest diameter	Formstahltyp	Modèle de l' outile	Skärståltyp	Tipo d' utensile	Modelo de la cuchilla
3	Carbide tool bit -no indication = normal quality -X indication = special quality	Hartmetall	Métal dur	Hårdmetall	Metallo duro	Metal duro
4	Internal term (not necessary for customer)	Interne Bezeichnung (nicht notwendig für den Kunden)	Nom interne (pas nécessaire pour le Client)	Intern namn (inte nödvändigt för kunden)	Nome interno (non necessario per il cliente)	Nombre interno (no es necesario para el cliente)
5	Seat width in mm	Sitzbreite in mm	Largeur du siège en mm	Sätessbredd i mm	Larghezza di sede in mm	Largura del asiento in mm
6	Seat angle in °	Sitzwinkel in °	Angle de siège en °	Sätessvinkel i °	Angolo di sde in °	Ángulo del asiento in °

**4 Order Form for Mira Formtools**  
**4 Bestellformular für Mira-Formstähle**  
**4 Bulletin de commande pour outils Mira**

Local dealer: \_\_\_\_\_ Name: \_\_\_\_\_ Date of purchase: \_\_\_\_\_

**Information needed about the Vehicle:**

Mark: \_\_\_\_\_ Vehicle: \_\_\_\_\_ Year: \_\_\_\_\_  
 Engine type: \_\_\_\_\_ Fuel/ Diesel: \_\_\_\_\_ Volume (ccm): \_\_\_\_\_

Information needed about the cylinderhead:

	<u>Inlet Valve:</u>				<u>Outlet Valve:</u>			
Seat width in mm:	S	=	_____	S	=	_____		
Seat angle in °:	$\alpha$	=	_____	$\alpha$	=	_____		
Upper correction length in mm:	UC	=	_____	UC	=	_____		
Upper correction angle in °:	$\gamma$	=	_____	$\gamma$	=	_____		
Lower correction length in mm:	LC	=	_____	LC	=	_____		
Lower correction angle in °:	$\beta$	=	_____	$\beta$	=	_____		
Valveguide:	$\emptyset$	=	_____	$\emptyset$	=	_____		
Carbide tool bit (normal or X)	N <input type="checkbox"/>	X <input type="checkbox"/>		N <input type="checkbox"/>	X <input type="checkbox"/>			
Holder type (valve- $\emptyset$ )	A <input type="checkbox"/>	B <input type="checkbox"/>	C <input type="checkbox"/>	DT <input type="checkbox"/>	A <input type="checkbox"/>	B <input type="checkbox"/>	C <input type="checkbox"/>	DT <input type="checkbox"/>

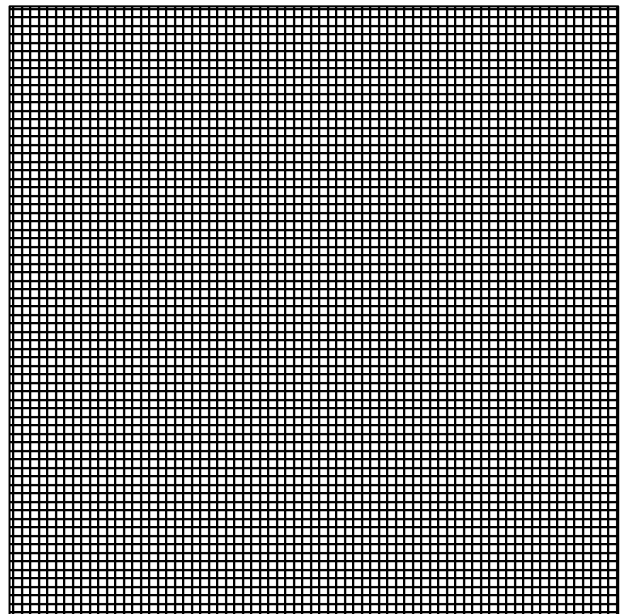
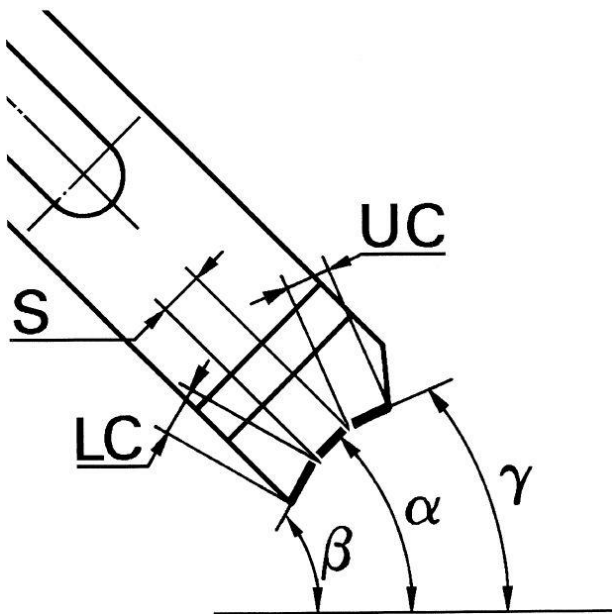



Please fill in this completely, this assures a prompt delivery without delays because of further information needed in production and also helps us to update our formtool list. If the requested formtool is very different from the one above, please fill in a drawing or add a copy of the manual.

Manufacturer and worldwide distributor:

**MINELLI CORPORATION**  
 8330 Pfäffikon/ ZH  
 Switzerland  
 Phone: +41 952 35 35 Fax: +41 952 35 60

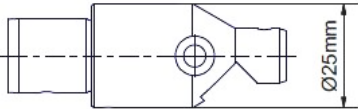
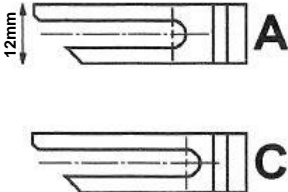
- 5 **Tool-heads and types of formtools**
- 5 **Drehköpfe und Formstahltypen**
- 5 **Têtes porte-outils et modèles d'outils**
- 5 **Skärhuvuden och Skärstålmodeller**
- 5 **Teste porta-utensili e Tipi d'utensili**
- 5 **Cabezales mandinadores y Modelos de cuchilla**

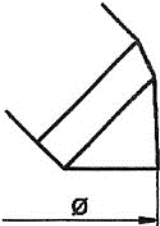
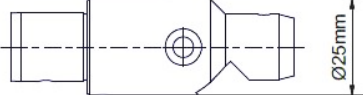
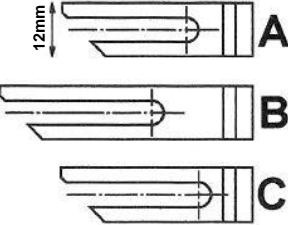
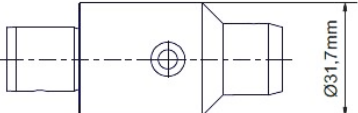
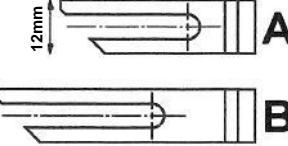
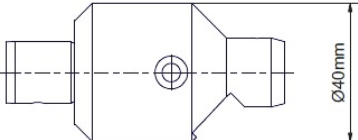
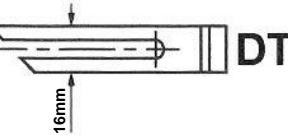
<p>Spindle size Drehkopf-Grösse Modèle de broche Storlek skärhuvud Modello testa porta-utensili Talla del cabezal mandrinador</p>	<p>Formtool model Formstahl-Typ Modèle de l'outil Skärståltyp Tipo d'utensile Modelo de la cuchilla</p>	<p>Processing-Ø (formtool 115) Bearbeitungs-Ø (Formstahl 115) Ø d'usinage (outil 115) Bearbetnings Ø (Skärstål 115) Ø di lavorazione (utensile 115) Ø de labra (cuchilla 115)</p>	<p>Processing-Ø ring seating tool 390 Bearbeitungs-Ø Ringsitzstahl 390 Ø d'usinage por un acier 390 Bearbetnings Ø Stål för ringsäten 390 Ø di lavorazione per un acciaio 390 Ø de labra por un acero 390</p>
<p><b>DT05 / (DRC05)</b> suitable for FDM, FDMH pilots</p> 		 <p><b>20 to / bis / à 35</b> <b>16 to / bis / à 30</b></p>	 <p><b>23 to / bis / à 38</b> <b>21 to / bis / à 34</b></p>
<p><b>DT1 / (DRC1)</b> suitable for FD pilots</p>  <p>(Standard model/ VGX-21) (Standardtyp/ VGX-21) (Modèle standard/ VGX-21)</p>		<p><b>23 to / bis / à 36</b> <b>31 to / bis / à 45</b> <b>21 to / bis / à 33</b></p>	<p><b>28 to / bis / à 38</b> <b>34 to / bis / à 48</b> <b>25 to / bis / à 35</b> <b>DSD Ø35 - 45</b></p>
<p><b>DT2 / (DRC2)</b> suitable for FD pilots</p> 		<p><b>37 to / bis / à 42</b> <b>38 to / bis / à 55</b></p>	<p><b>42 to / bis / à 48</b> <b>42 to / bis / à 58</b> <b>DSD Ø45 - 55</b></p>
<p><b>DT3</b> suitable for FD pilots</p> 		<p><b>35 to / bis / à 75</b></p>	<p><b>DSD Ø55 - 75</b></p>



- 6 Pilots
- 6 Führungsdorne
- 6 *Pilotes*
- 6 *Styrspindlar*
- 6 Piloti
- 6 *Pilotos*

**Plug-in Pilots**

Suitable for DT-, DRC-tool-head models

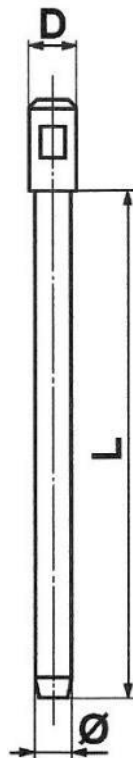

**FD**            Ø        5.87 – 9.20  
                   D=        Ø 9.52  
                   L=        100

**FD**            Ø        9.30 – 16.00  
                   D=        Ø 9.52  
                   L=        138

**FDM**            Ø        3.49 – 6.02  
                   D=        Ø 6.00  
                   L=        80

**FDMH**            sintered carbide type  
                   only available on request

**7 mira formtool list**  
**7 mira Formstahlliste**  
**7 mira list des outils de façon**

Specification		seatwidth	seatangle	Cutting angle	Clearance angle	Lower correction		1. Upper correction		2. Upper correction		Page
Bezeichnung		Sitzbreite	Sitzwinkel	Schnittwinkel	Freiwinkel	Untere Korrektur		1. Obere Korrektur		2. Ober Korrektur		Seite
		S	$\sphericalangle\alpha$	$\sphericalangle\delta$	$\sphericalangle\varepsilon$	$\sphericalangle\beta$	L	$\sphericalangle\gamma$	L	$\sphericalangle\gamma$	L	Nr.
105C	0.5/45°	0.50	45°30'	3°	15°	60°	3.5	25°	1.5			17
107C	0.7/45°	0.70	45°30'	3°	15°	60°	3.5	25°	1.5			17
108A	0.8/45°	0.80	45°30'	3°	10°	60°	3.5	25°	1.5			17
108B	0.8/45°	0.80	45°30'	3°	10°	60°	3.5	25°	1.5			17
108C	0.8/45°	0.80	45°30'	3°	15°	60°	3.5	25°	1.5			17
108CX	0.8/45°	0.80	45°30'	3°	15°	60°	3.5	25°	1.5			17
110A	1.0/45°	1.00	45°30'	3°	10°	60°	3.5	25°	1.5			17
110AX	1.0/45°	1.00	45°30'	3°	10°	60°	3.5	25°	1.5			17
110B	1.0/45°	1.00	45°30'	3°	10°	60°	3.5	25°	1.5			17
110BX	1.0/45°	1.00	45°30'	3°	10°	60°	3.5	25°	1.5			17
110C	1.0/45°	1.00	45°30'	3°	15°	60°	3.5	25°	1.5			17
110CX	1.0/45°	1.00	45°30'	3°	15°	60°	3.5	25°	1.5			17
115A	1.5/45°	1.50	45°30'	3°	10°	60°	3.5	25°	1.5			16
115AX	1.5/45°	1.50	45°30'	3°	10°	60°	3.5	25°	1.5			17
115B	1.5/45°	1.50	45°30'	3°	10°	60°	3.5	25°	1.5			17
115BX	1.5/45°	1.50	45°30'	3°	10°	60°	3.5	25°	1.5			17
115C	1.5/45°	1.50	45°30'	3°	15°	60°	3.5	25°	1.5			17
115CX	1.5/45°	1.50	45°30'	3°	15°	60°	3.5	25°	1.5			17
115DT	1.5/45°	1.50	45°30'	3°	10°	60°	3.5	25°	1.5			17
120A	2.0/45°	2.00	45°30'	3°	10°	60°	3.5	25°	1.5			16
120AX	2.0/45°	2.00	45°30'	3°	10°	60°	3.5	25°	1.5			17
120B	2.0/45°	2.00	45°30'	3°	10°	60°	3.5	25°	1.5			17
120BX	2.0/45°	2.00	45°30'	3°	10°	60°	3.5	25°	1.5			17
120CX	2.0/45°	2.00	45°30'	3°	15°	60°	3.5	25°	1.5			17
120DT	2.0/45°	2.00	45°30'	3°	10°	60°	3.5	25°	1.5			17
120DTX	2.0/45°	2.00	45°30'	3°	10°	60°	3.5	25°	1.5			17
125A	2.5/45°	2.50	45°30'	3°	10°	60°	3.5	25°	1.5			17
125AX	2.5/45°	2.50	45°30'	3°	10°	60°	3.5	25°	1.5			17
125B	2.5/45°	2.50	45°30'	3°	10°	60°	3.5	25°	1.5			16
125BX	2.5/45°	2.50	45°30'	3°	10°	60°	3.5	25°	1.5			17
125DT	2.5/45°	2.50	45°30'	3°	10°	60°	3.5	25°	1.5			17
125DTX	2.5/45°	2.50	45°30'	3°	10°	60°	3.5	25°	1.5			17
130B	3.0/45°	3.00	45°30'	3°	10°	60°	3.5	25°	1.5			17
130BX	3.0/45°	3.00	45°30'	3°	10°	60°	3.5	25°	1.5			17
135B	3.5/45°	3.50	45°30'	3°	10°	60°	3.5	25°	1.5			17
135DT	3.5/45°	3.50	45°30'	3°	10°	60°	3.5	25°	1.5			17
140B	4.0/45°	4.00	45°30'	3°	10°	60°	3.5	25°	1.5			17
208C	0.8/30°	0.80	30°30'	3°	15°	60°	3.5	15°	1.5			27
210A	1.0/30°	1.00	30°30'	3°	10°	60°	3.5	15°	1.5			27
210AX	1.0/30°	1.00	30°30'	3°	10°	60°	3.5	15°	1.5			27
210B	1.0/30°	1.00	30°30'	3°	10°	60°	3.5	15°	1.5			27
210BX	1.0/30°	1.00	30°30'	3°	10°	60°	3.5	15°	1.5			27
210C	1.0/30°	1.00	30°30'	3°	15°	60°	3.5	15°	1.5			27
212B	1.2/30°	1.20	30°30'	3°	10°	60°	3.5	15°	1.5			27
215A	1.5/30°	1.50	30°30'	3°	10°	60°	3.5	15°	1.5			26

Specification		seatwidth	seatangle	Cutting angle	Clearance angle	Lower correction		1. Upper correction		2. Upper correction		Page
Bezeichnung		Sitzbreite	Sitzwinkel	Schnittwinkel	Freiwinkel	Untere Korrektur		1. Obere Korrektur		2. Ober Korrektur		Seite
		S	$\sphericalangle\alpha$	$\sphericalangle\delta$	$\sphericalangle\varepsilon$	$\sphericalangle\beta$	L	$\sphericalangle\gamma$	L	$\sphericalangle\gamma$	L	Nr.
215AX	1.5/30°	1.50	30°30'	3°	10°	60°	3.5	15°	1.5			27
215B	1.5/30°	1.50	30°30'	3°	10°	60°	3.5	15°	1.5			27
215BX	1.5/30°	1.50	30°30'	3°	10°	60°	3.5	15°	1.5			27
215C	1.5/30°	1.50	30°30'	3°	15°	60°	3.5	15°	1.5			27
215CX	1.5/30°	1.50	30°30'	3°	15°	60°	3.5	15°	1.5			27
215DT	1.5/30°	1.50	30°30'	3°	10°	60°	3.5	15°	1.5			27
220A	2.0/30°	2.00	30°30'	3°	10°	60°	3.5	15°	1.5			26
220AX	2.0/30°	2.00	30°30'	3°	10°	60°	3.5	15°	1.5			27
220B	2.0/30°	2.00	30°30'	3°	10°	60°	3.5	15°	1.5			27
220BX	2.0/30°	2.00	30°30'	3°	10°	60°	3.5	15°	1.5			27
220DT	2.0/30°	2.00	30°30'	3°	10°	60°	3.5	15°	1.5			27
225B	2.5/30°	2.50	30°30'	3°	10°	60°	3.5	15°	1.5			26
225BX	2.5/30°	2.50	30°30'	3°	10°	60°	3.5	15°	1.5			27
225DT	2.5/30°	2.50	30°30'	3°	10°	60°	3.5	15°	1.5			27
230B	3.0/30°	3.00	30°30'	3°	10°	60°	3.5	15°	1.5			27
230BX	3.0/30°	3.00	30°30'	3°	10°	60°	3.5	15°	1.5			27
230DT	3.0/30°	3.00	30°30'	3°	10°	60°	3.5	15°	1.5			27
235B	3.5/30°	3.50	30°30'	3°	10°	60°	3.5	15°	1.5			27
240B	4.0/30°	4.00	30°30'	3°	10°	60°	3.5	15°	1.5			27
301A	45°	9.00	45°30'	3°	10°							32
301AX	45°	9.00	45°30'	3°	10°							32
301B	45°	9.00	45°30'	3°	10°							32
301BX	45°	9.00	45°30'	3°	10°							32
301C	45°	9.00	45°30'	3°	15°							32
301CX	45°	9.00	45°30'	3°	15°							32
301DT	45°	13.00	45°30'	3°	10°							32
302A	30°	9.00	30°30'	3°	10°							32
302AX	30°	9.00	30°30'	3°	10°							32
302B	30°	9.00	30°30'	3°	10°							32
302BX	30°	9.00	30°30'	3°	10°							32
302C	30°	9.00	30°30'	3°	15°							32
302CX	30°	9.00	30°30'	3°	15°							32
302DT	30°	9.00	30°30'	3°	10°							32
303B	35°	10.00	35°30'	3°	10°							32
303BX	35°	10.00	35°30'	3°	10°							32
304B	45°	12.00	45°30'	3°	10°							32
304BX	45°	12.00	45°30'	3°	10°							32
305B	30°	12.00	30°30'	3°	10°							32
305BX	30°	12.00	30°30'	3°	10°							32
306A	20°	7.50	20°30'	3°	10°							32
306B	20°	7.50	20°30'	3°	10°							32
306BX	20°	7.50	20°30'	3°	10°							32
306DT	20°	7.50	20°30'	3°	10°							32
351A	75°			3°	10°	75°	14.0					32
351B	75°			3°	10°	75°	14.0					32
351BX	75°			3°	10°	75°	14.0					32
351C	75°			3°	15°	75°	14.0					32
351CX	75°			3°	15°	75°	14.0					32
352A	15°			3°	10°			15°	9.5			33
352B	15°			3°	10°			15°	9.5			33
352BX	15°			3°	10°			15°	9.5			33

Specification		seatwidth	seatangle	Cutting angle	Clearance angle	Lower correction		1. Upper correction		2. Upper correction		Page
Bezeichnung		Sitzbreite	Sitzwinkel	Schnittwinkel	Freiwinkel	Untere Korrektur		1. Obere Korrektur		2. Ober Korrektur		Seite
		S	α	δ	ε	β	L	γ	L	γ	L	Nr.
352DT	15°			3°	10°			15°	9.5			33
353A	75°			3°	10°	75°	7.0					32
353B	75°			3°	10°	75°	7.0					32
354B	15°			3°	10°			15°	4.0	R7.0		33
355B	38°			3°	10°			38°	6.5	R5.4		33
357B	39°			3°	10°			39°	2.0	R6.5		33
358B				3°	10°	R27.5						32
360B	25°			3°	10°			25°	9.5			33
362A	60°			3°	10°	60°	11.0					32
262B	60°			3°	10°	60°	11.0					32
363B	80°			3°	10°							33
365A	85°			3°	10°	85°	12.0					32
365B	85°			3°	10°	85°	12.0					32
390A		8.00	0°0'	3°	10°							33
390AX		8.00	0°0'	3°	10°							33
390B		8.00	0°0'	3°	10°							33
390BX		8.00	0°0'	3°	10°							33
390C		8.00	0°0'	3°	15°							33
390CX		8.00	0°0'	3°	15°							33
390DT		8.00	0°0'	3°	10°							33
4001A	1.0/45°	1.00	45°30'	3°	10°	60°	3.5	0°	1.5			18
4002A	1.5/45°	1.50	45°30'	3°	10°	60°	3.5	0°	1.5			21
4003A	2.0/45°	2.00	45°30'	3°	10°	60°	3.5	0°	1.5			22
4003B	2.0/45°	2.00	45°30'	3°	10°	60°	3.5	0°	1.5			22
4004A	1.0/45°	1.00	45°30'	3°	10°	60°	3.5	30°	1.5			18
4004B	1.0/45°	1.00	45°30'	3°	10°	60°	3.5	30°	1.5			18
4005A	1.5/45°	1.50	45°30'	3°	10°	55°	3.5	30°	1.5			21
4005AX	1.5/45°	1.50	45°30'	3°	10°	55°	3.5	30°	1.5			21
4005B	1.5/45°	1.50	45°30'	3°	10°	55°	3.5	30°	1.5			21
4005BX	1.5/45°	1.50	45°30'	3°	10°	55°	3.5	30°	1.5			21
4006A	2.0/45°	2.00	45°30'	3°	10°	55°	3.5	30°	1.5			22
4006AX	2.0/45°	2.00	45°30'	3°	10°	55°	3.5	30°	1.5			22
4006B	2.0/45°	2.00	45°30'	3°	10°	55°	3.5	30°	1.5			22
4006BX	2.0/45°	2.00	45°30'	3°	10°	55°	3.5	30°	1.5			22
4009A	6.0/45°	6.00	45°30'	3°	10°	60°	3.5					25
4010B	2.8/45°	2.80	45°30'	3°	10°	60°	3.5	0°	0.3	45°	5.5	24
4011B	4.2/45°	4.20	45°30'	3°	10°	60°	2.5	0°	0.7	45°	5.0	24
4012B	2.0/45°	2.00	45°30'	3°	10°	60°	2.5	0°	0.7	60°	7.0	23
4015B	3.0/45°	3.00	45°30'	3°	10°	60°	3.5	R0.6				24
4016B	3.5/45°	3.50	45°30'	3°	10°	60°	3.5	R0.6				24
4018B	1.5/45°	1.50	45°30'	3°	10°	70°	4.0	0°	0.4	45°	7.0	21
4020A	1.5/45°	1.50	45°30'	3°	10°	65°	3.5	R2.0				21
4021A	1.7/45°	1.70	45°30'	3°	10°	65°	3.5	R2.0				22
4022B	1.7/45°	1.70	45°30'	3°	10°	60°	5.0	0°	0.8			22
4023B	5.0/45°	5.00	45°30'	3°	10°	60°	4.5					24
4025B	2.0/45°	2.00	45°30'	3°	10°	65°	3.5	38°	2.6	R1.5		23
4025BX	2.0/45°	2.00	45°30'	3°	10°	65°	3.5	38°	2.6	R1.5		23
4027B	2.0/45°	2.00	45°30'	3°	10°	60°	6.0	0°	1.0	60°	2.5	23
4028B	3.0/45°	3.00	45°30'	3°	10°	60°	6.0	0°	1.0	60°	2.5	24
4029A	1.0/45°	1.00	45°30'	3°	10°	R12		15°	2.0			18
4029B	1.0/45°	1.00	45°30'	3°	10°	R12		15°	2.0			18

Specification		seatwidth	seatangle	Cutting angle	Clearance angle	Lower correction		1. Upper correction		2. Upper correction		Page
Bezeichnung		Sitzbreite	Sitzwinkel	Schnittwinkel	Freiwinkel	Untere Korrektur		1. Obere Korrektur		2. Ober Korrektur		Seite
		S	$\sphericalangle\alpha$	$\sphericalangle\delta$	$\sphericalangle\varepsilon$	$\sphericalangle\beta$	L	$\sphericalangle\gamma$	L	$\sphericalangle\gamma$	L	Nr.
4030B	1.3/45°	1.30	45°30'	3°	10°	65°	3.5	38°	2.5	R1.5		20
4030BX	1.3/45°	1.30	45°30'	3°	10°	65°	3.5	38°	2.6	R1.5		20
4030C	1.3/45°	1.30	45°30'	3°	15°	65°	3.5	38°	2.6	R1.5		20
4032A	1.0/45°	1.00	45°30'	3°	10°	75°	7.0	15°	2.3	R0.7		18
4033B	1.5/45°	1.50	45°30'	3°	10°	60°	3.0	30°	3.2			21
4034B	2.0/45°	2.00	45°30'	3°	10°	72.5°	4.5	0°	1.1	62°	5.0	23
4036A	1.2/45°	1.20	45°30'	3°	10°	60°	5.0	15°	2.0			20
4036B	1.2/45°	1.20	45°30'	3°	10°	60°	5.0	15°	2.0			20
4036BX	1.2/45°	1.20	45°30'	3°	10°	60°	5.0	15°	2.0			20
4037A	1.0/45°	1.00	45°30'	3°	15°	53°	3.5	35°	1.5			18
4037AX	1.0/45°	1.00	45°30'	3°	10°	53°	3.5	35°	1.5			18
4037B	1.0/45°	1.00	45°30'	3°	10°	53°	3.5	35°	1.5			18
4037BX	1.0/45°	1.00	45°30'	3°	10°	53°	3.5	35°	1.5			18
4037CX	1.0/45°	1.00	45°30'	3°	15°	53°	3.5	35°	1.5			18
4038A	1.5/45°	1.50	45°30'	3°	10°	53°	3.5	35°	1.5			21
4038AX	1.5/45°	1.50	45°30'	3°	10°	53°	3.5	35°	1.5			21
4038B	1.5/45°	1.50	45°30'	3°	10°	53°	3.5	35°	1.5			21
4038BX	1.5/45°	1.50	45°30'	3°	10°	53°	3.5	35°	1.5			21
4038C	1.5/45°	1.50	45°30'	3°	15°	53°	3.5	35°	1.5			21
4039B	2.0/45°	2.00	45°30'	3°	10°	53°	3.5	35°	1.5			23
4039BX	2.0/45°	2.00	45°30'	3°	10°	53°	3.5	35°	1.5			23
4040B	2.5/45°	2.50	45°30'	3°	10°	53°	3.5	35°	1.5			24
4041A	1.0/45°	1.00	45°30'	3°	10°	82°	R0.5	30°	1.7	R2.5		19
4041B	1.0/45°	1.00	45°30'	3°	10°	82°	R0.5	30°	1.7	R2.5		19
4042B	1.0/45°	1.00	45°30'	3°	10°	65°	5.5	32°	2.5			19
4043A	1.0/45°	1.00	45°30'	3°	10°	R12	3.0	35°	2.0	R1.0		19
4043B	1.0/45°	1.00	45°30'	3°	10°	R12	3.0	35°	2.0	R1.0		19
4043BX	1.0/45°	1.00	45°30'	3°	10°	R12	3.0	35°	2.0	R1.0		19
4045B	1.0/45°	1.00	45°30'	3°	10°	R5.0	2.5	40°	2.0			19
4046B	1.0/45°	1.00	45°30'	3°	10°	R5.0	4.0	40°	2.0			19
4047B	1.0/45°	1.00	45°30'	3°	10°	R12		40°	2.0			19
4048B	1.0/45°	1.00	45°30'	3°	10°	R12	3.5	40°	2.0			19
4050B	1.0/45°	1.00	45°30'	3°	10°	74°	7.0	35°	2.0			19
4052B	1.5/45°	1.50	45°30'	3°	10°	60°	3.5	R6.0				21
4053B	1.5/45°	1.50	45°30'	3°	10°	53°	3.5	37°	1.7			21
4058B	1.5/45°	1.50	45°30'	3°	10°	60°	3.5	0°	0.7	60°	6.5	21
4060A	1.4/45°	1.40	45°30'	3°	10°	75°	3.5	32.5°	1.0	R5.0		21
4060B	1.4/45°	1.40	45°30'	3°	10°	75°	3.5	32.5°	1.0	R5.0		21
4061A	1.4/45°	1.40	45°30'	3°	10°	75°	3.5	32.5°	1.5	R6.0	R2.0	21
4063A	1.0/45°	1.00	45°30'	3°	10°	R6.0		R4.7				19
4063B	1.0/45°	1.00	45°30'	3°	10°	R6.0		R4.7				19
4064A	0.8/45°	0.80	45°30'	3°	10°	60°	4.5	32.5°	1.0	R5.0		18
4064B	0.8/45°	0.80	45°30'	3°	10°	60°	4.5	32.5°	1.0	R5.0		18
4064C	0.8/45°	0.80	45°30'	3°	15°	60°	4.5	32.5°	1.0	R5.0		18
4065B	1.2/45°	1.20	45°30'	3°	10°	65°	4.5	35°	1.5	R0.9		20
4072B	7.0/45°	7.00	45°30'	3°	10°	60°	4.0					25
4072BX	7.0/45°	7.00	45°30'	3°	10°	60°	4.0					25
4074A	1.5/45°	1.50	45°30'	3°	10°	R12		15°	2.0			22
4074B	1.5/45°	1.50	45°30'	3°	10°	R12		15°	2.0			22
4076B	1.3/45°	1.30	45°30'	3°	10°	R6.6	4.5	37.5°	2.0			20
4077B	1.3/45°	1.30	45°30'	3°	10°	55°	2.5	40°	2.5			20

Specification		seatwidth	seatangle	Cutting angle	Clearance angle	Lower correction		1. Upper correction		2. Upper correction		Page
Bezeichnung		Sitzbreite	Sitzwinkel	Schnittwinkel	Freiwinkel	Untere Korrektur		1. Obere Korrektur		2. Ober Korrektur		Seite
		S	α	δ	ε	β	L	γ	L	γ	L	Nr.
4080B	2.0/45°	2.00	45°30'	3°	10°	60°	3.5	0°	0.3	45°	6.5	23
4081BX	2.0/45°	2.00	45°30'	3°	10°	55°	3.5	30°	4.0			23
4086B	1.0/45°	1.00	45°30'	3°	10°	65°	4.0	R6.0				19
4086C	1.0/45°	1.00	45°30'	3°	15°	65°	4.0	R6.0				19
4087B	1.2/45°	1.20	45°30'	3°	10°	65°	4.0	R6.0				20
4090C	1.3/45°	1.30	45°30'	3°	15°	65°	4.0	R6.3				20
4091A	3.0/45°	3.00	45°30'	3°	10°	75°	8.0					24
4092B	4.0/45°	4.00	45°30'	3°	10°	R10						24
4093B	3.0/45°	3.00	45°30'	3°	10°	60°	3.5	30°	1.5			24
4094B	1.2/45°	1.20	45°30'	3°	10°	70°	7.5	20°	1.1			20
4095B	1.0/45°	1.00	45°30'	3°	10°	R4.0	4.5	20°	2.0	R2.0		19
4096B	2.3/45°	2.30	45°30'	3°	10°	70°	6.0	0°	1.5			23
4098B	1.5/45°	1.50	45°30'	3°	10°	R12		40°	2.0			22
4099B	1.3/45°	1.30	45°30'	3°	10°	60°	3.5	30°	2.0			20
4100B	1.4/45°	1.40	45°30'	3°	10°	60°	4.0	35°	2.5			21
4101B	1.2/45°	1.20	45°30'	3°	10°	60°	3.5	35°	2.0			20
4102B	1.1/45°	1.10	45°30'	3°	10°	60°	3.5	38°	2.5			20
4104B	1.5/45°	1.50	45°30'	3°	10°	R12	3.0	35°	2.0	R1.0		22
4105B	2.0/45°	2.00	45°30'	3°	10°	R12	3.0	35°	2.0	R1.0		23
4107BX	2.5/45°	2.50	45°30'	3°	10°	75°	4.0	15°	3.0	R0.4		24
4109A	1.5/45°	1.50	45°30'	3°	10°	70°	5.0	0°	0.9			22
4110A	2.0/45°	2.00	45°30'	3°	10°	70°	5.0	0°	0.7			23
4111A	2.0/45°	2.00	45°30'	3°	10°	70°	5.0	0°	1.2			23
4112A	1.5/45°	1.50	45°30'	3°	10°	70°	5.0	0°	1.1			22
4120B	1.2/45°	1.20	45°30'	3°	10°	70°	4.5	30°	2.0			25
4121A	2.0/45°	2.00	45°30'	3°	10°	75°	7.0	15°	2.3	R0.7		23
4122BX	1.5/45°	1.50	45°30'	3°	10°	75°	6.0	15°	3.5			22
4129B	1.5/45°	1.50	45°30'	3°	10°	75°	5.0	15°	1.5			22
4130A	2.0/45°	2.00	45°30'	3°	10°	75°	5.0	15°	1.5			23
4130B	2.0/45°	2.00	45°30'	3°	10°	75°	5.0	15°	1.5			23
4131C	1.1/45°	1.10	45°30'	3°	15°	65°	4.0		1.5	R6.3		20
4132C	1.2/45°	1.20	45°30'	3°	15°	65°	4.0		1.5	R6.3		20
4135B	1.0/45°	1.00	45°30'	3°	10°	82°	7.0	20°	1.0			19
4136B	R1.5			3°	10°	82°	7.0	15°	1.0	R0.8		25
4138B	1.5/45°	1.50	45°30'	3°	10°	R5.0	4.0	30°	3.0	R1.0		22
4139BX	3.0/45°	3.00	45°30'	3°	10°	65°	3.5	38°	2.6	R1.5		24
4140B	1.7/45°	1.70	45°30'	3°	10°	60°	5.0	30°	1.5			22
4141B	0.8/45°	0.80	45°30'	3°	10°	R3.4	4.5	R2.6		45°	0.7	18
4142B	0.8/45°	0.80	45°30'	3°	10°	R3.5	4.5	R1.0		R5.4		18
4143B	0.8/45°	0.80	45°30'	3°	10°	R5.5	6.0	R2.2		45°	0.7	18
4144A	1.0/45°	1.00	45°30'	3°	10°	60°	7.0	30°	4.0			19
4144B	1.0/45°	1.00	45°30'	3°	10°	60°	7.0	30°	4.0			19
4146A	0.5/45°	0.50	45°30'	3°	10°	75°	4.5	30°	4.0	R0.7		18
4147A	1.3/45°	1.30	45°30'	3°	10°	75°	4.0	30°	2.0			20
4148A	1.3/45°	1.30	45°30'	3°	10°	75°	3.5	15°	1.0			21
4150B	3.5/45°	3.50	45°30'	3°	10°	65°	7.0	5°	2.0			24
4157B	1.3/45°	1.30	45°30'	3°	10°	R12		30°	2.5			21
4158B	4.5/45°	4.50	45°30'	3°	10°			0°	0.7	45°	7.0	24
4159B	5.5/45°	5.50	45°30'	3°	10°			0°	0.5	45°	6.0	24
4182A	0.8/45°	0.80	45°30'	3°	10°	65°	5.5	32°	2.5			18
4187A	2.0/45°	2.00	45°30'	3°	10°	70°	3.5	30°	1.5			23

Specification		seatwidth	seatangle	Cutting angle	Clearance angle	Lower correction		1. Upper correction		2. Upper correction		Page
Bezeichnung		Sitzbreite	Sitzwinkel	Schnittwinkel	Freiwinkel	Untere Korrektur		1. Obere Korrektur		2. Ober Korrektur		Seite
		S	$\sphericalangle\alpha$	$\sphericalangle\delta$	$\sphericalangle\varepsilon$	$\sphericalangle\beta$	L	$\sphericalangle\gamma$	L	$\sphericalangle\gamma$	L	Nr.
4188A	2.4/45°	2.40	45°30'	3°	10°	70°	3.5	30°	1.5			23
4203A	1.4/45°	1.40	45°30'	3°	10°	70°	3.3	30°	2.5	R0.5		21
4229B	0.85/45°	0.85	45°30'	3°	10°	R9.5	1.0	30°	2.0	R3.0		18
4229CX	0.85/45°	0.85	45°30'	3°	15°	R9.5	1.0	30°	2.0	R3.0		18
4231A	0.8/45°	0.80	45°30'	3°	10°	60°	3.5	30°	1.5			18
4231C	0.8/45°	0.80	45°30'	3°	15°	60°	3.5	30°	1.5			18
4232A	1.0/45°	1.00	45°30'	3°	10°	60°	3.5	30°	1.5			19
4232C	1.0/45°	1.00	45°30'	3°	15°	60°	3.5	30°	1.5			19
4232CX	1.0/45°	1.00	45°30'	3°	15°	60°	3.5	30°	1.5			19
4243A	1.5/45°	1.50	45°30'	3°	10°	67°	3.5	30°	1.5			22
4248A	1.0/45°	1.00	45°30'	3°	10°	R3.0	3.0	25°	1.0	R2.0		19
4254A	1.5/45°	1.50	45°30'	3°	10°	65°	3.5	38°	2.6	R1.5		22
4268A	1.0/45°	1.00	45°30'	3°	10°	65°	3.5	38°	2.6	R1.5		20
4444A	0.85/45°	0.85	45°30'	3°	10°	70°	3.5	30°	1.2			18
4460C	0.85/45°	0.85	45°30'	3°	15°	R3.3	0.5	30°	1.2			18
4502B	2.0/30°	2.00	30°30'	3°	10°	74°	4.0	15°	1.5			28
4503B	2.0/35°	2.00	35°30'	3°	10°	60°	3.5	15°	1.5			31
4504B	1.5/30°	1.50	30°30'	3°	10°	60°	3.5	0°	2.0			28
4505BX	2.6/38°	2.60	38°30'	3°	10°	60°	3.5	15°	1.5			31
4506B	3.5/30°	3.50	30°30'	3°	10°	60°	3.5	R0.6				29
4507B	3.2/35°	3.20	35°30'	3°	10°	75°	5.5	0°	1.0			31
4508B	1.7/35°	1.70	35°30'	3°	10°	60°	5.0	0°	1.0			31
4509BX	2.0/30°	2.00	30°30'	3°	10°	65°	3.5	23°	1.5	R1.5		28
4510B	1.0/30°	1.00	30°30'	3°	10°	R12		15°	2.0			28
4512BX	2.5/30°	2.50	30°30'	3°	10°	75°	4.0	15°	3.5			29
4514B	1.0/30°	1.00	30°30'	3°	10°	52°	3.5	23°	1.5			28
4515A	1.5/30°	1.50	30°30'	3°	10°	52°	3.5	23°	1.5			28
4515AX	1.5/30°	1.50	30°30'	3°	10°	52°	3.5	23°	1.5			28
4515B	1.5/30°	1.50	30°30'	3°	10°	52°	3.5	23°	1.5			28
4515BX	1.5/30°	1.50	30°30'	3°	10°	52°	3.5	23°	1.5			28
4516B	2.0/30°	2.00	30°30'	3°	10°	52°	3.5	23°	1.5			28
4516BX	2.0/30°	2.00	30°30'	3°	10°	52°	3.5	23°	1.5			28
4517B	2.5/30°	2.50	30°30'	3°	10°	52°	3.5	23°	1.5			29
4518A	1.2/30°	1.20	30°30'	3°	10°	55°	3.5	10°	1.7			28
4519B	3.0/30°	3.00	30°30'	3°	10°	60°	3.5	0°	1.0	R1.7		29
4520B	0.7/30°	0.75	30°30'	3°	10°	R9.2	3.5	20°	1.5	R0.9		28
4523B	2.5/20°	2.50	20°30'	3°	10°	60°	4.0	0°	1.8			30
4524B	2.0/20°	2.00	20°30'	3°	10°	60°	4.0	0°	1.8			30
4525B	2.0/30°	2.00	30°30'	3°	10°	60°	4.5	15°	0.8			28
4526BX	2.0/30°	2.00	30°30'	3°	10°	60°	5.0	15°	3.5			28
4529B	1.5/35°	1.50	35°30'	3°	10°	60°	3.5	15°	1.5			31
4530BX	1.2/30°	1.20	30°30'	3°	10°	75°	4.0	15°	2.0			28
4531B	7.0/30°	7.00	30°30'	3°	10°			15°	2.5			29
4535B	5.0/30°	5.00	30°30'	3°	10°	60°	4.0					29
4535BX	5.0/30°	5.00	30°30'	3°	10°	60°	4.0					29
4542B	2.0/35°	2.00	35°30'	3°	10°	70°	3.2	7°	1.0			31
4543BX	1.5/30°	1.50	30°30'	3°	10°	75°	4.0	15°	3.5			28
4544B	3.25/20°	3.25	20°30'	3°	10°	60°	6.2					30
4544BX	3.25/20°	3.25	20°30'	3°	10°	60°	6.2					30
4547B	1.5/30°	1.50	30°30'	3°	10°	75°	5.0	15°	1.5			28
4549BX	3.0/30°	3.00	30°30'	3°	10°	65°	3.5	23°	1.5	R1.5		29

Specification		seatwidth	seatangle	Cutting angle	Clearance angle	Lower correction		1. Upper correction		2.Upper correction		Page
Bezeichnung		Sitzbreite	Sitzwinkel	Schnittwinkel	Freiwinkel	Untere Korrektur		1. Obere Korrektur		2. Ober Korrektur		Seite
		S	$\sphericalangle\alpha$	$\sphericalangle\delta$	$\sphericalangle\varepsilon$	$\sphericalangle\beta$	L	$\sphericalangle\gamma$	L	$\sphericalangle\gamma$	L	Nr.
4552B	3.0/20°	3.00	20°30'	3°	10°	60°	3.5	15°	1.5			30
4552BX	3.0/20°	3.00	20°30'	3°	10°	60°	3.5	15°	1.5			30
4557B	4.5/30°	4.50	30°30'	3°	10°			0°	0.4	45°	7.3	29
4558B	2.0/37.5°	2.00	37.5°	3°	10°	60°	3.5	15°	1.5			31
4567B	9.0/30°	9.00	30°30'	3°	10°			0°	0.5			29



- 8 Standard Formtool 45°
- 8 Standard-Formstähle 45°
- 8 *Outils de façon standard 45°*
- 8 *Standard skärstål 45°*
- 8 Utensili ad angolazione multipla standard 45°
- 8 *Cuchillas de mandrinado moldeada standard 45°*

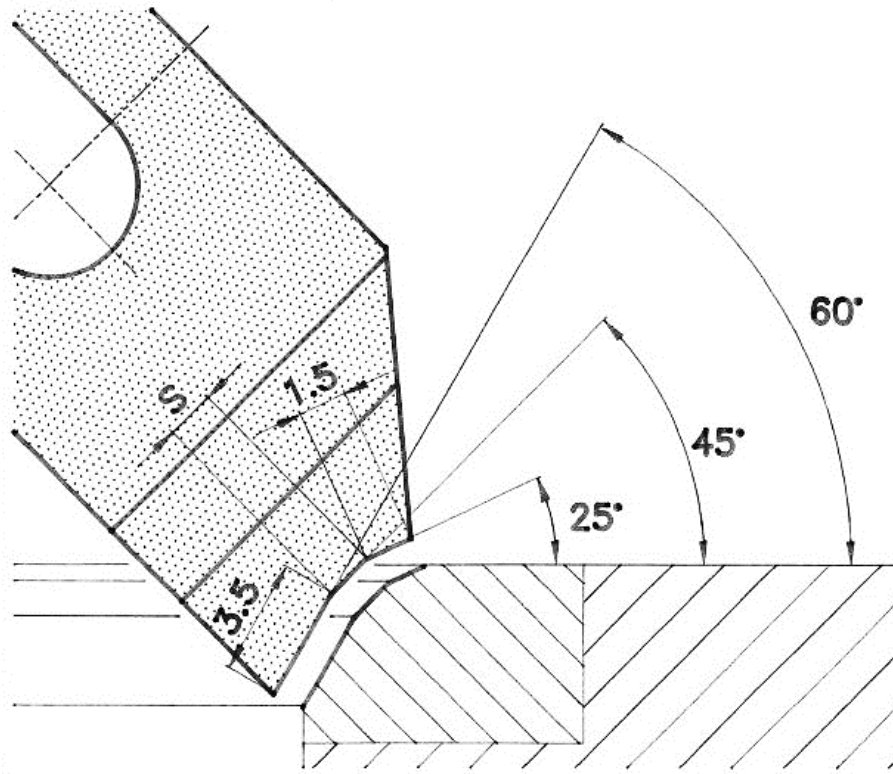

mira reference	Seat width	Seat angle
115A 1.5/45°	1.5	45°30'
120A 2.0/45°	2.0	45°30'
125B 2.5/45°	2.5	45°30'

- 9 Formtools 45°
- 9 Formst le 45°
- 9 Outils de fa on 45°
- 9 Sk rst l 45°
- 9 Utensili ad angolazione multipla 45°
- 9 Cuchillas de mandrinado moldeada 45°

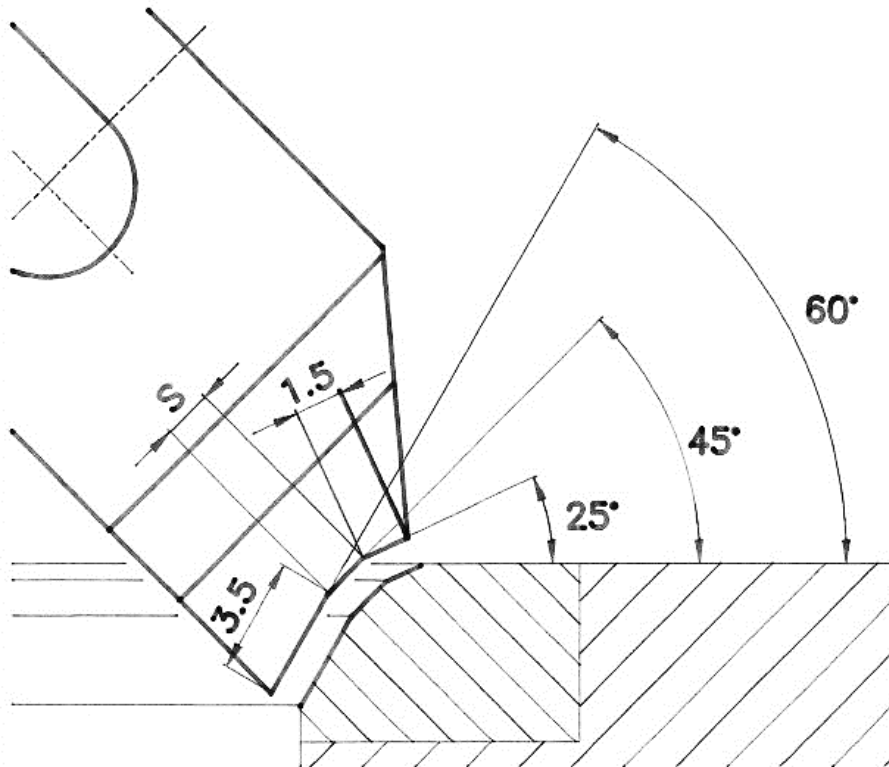

mira reference	Seat width	Seat angle
105C	0.5/45°	45°30'
107C	0.7/45°	45°30'
108A	0.8/45°	45°30'
108B	0.8/45°	45°30'
108C	0.8/45°	45°30'
108CX	0.8/45°	45°30'
110A	1.0/45°	45°30'
110AX	1.0/45°	45°30'
110B	1.0/45°	45°30'
110BX	1.0/45°	45°30'
110C	1.0/45°	45°30'
110CX	1.0/45°	45°30'
115AX	1.5/45°	45°30'
115B	1.5/45°	45°30'
115BX	1.5/45°	45°30'
115C	1.5/45°	45°30'
115CX	1.5/45°	45°30'
115DT	1.5/45°	45°30'

mira reference	Seat width	Seat angle
120AX	2.0/45°	45°30'
120B	2.0/45°	45°30'
120BX	2.0/45°	45°30'
120DT	2.0/45°	45°30'
125A	2.5/45°	45°30'
125BX	2.5/45°	45°30'
125DT	2.5/45°	45°30'
130B	3.0/45°	45°30'
130BX	3.0/45°	45°30'
135B	3.5/45°	45°30'
135DT	3.5/45°	45°30'
140B	4.0/45°	45°30'

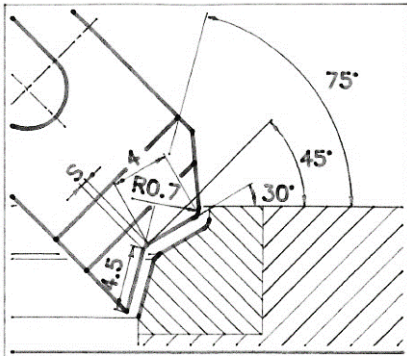

4146 S=0.5mm

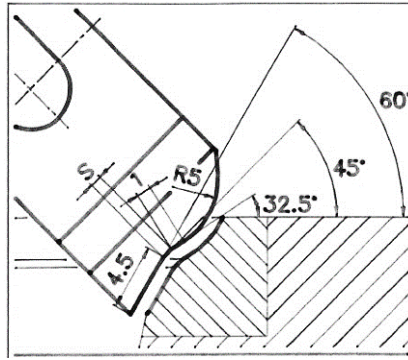

4064 S=0.8mm

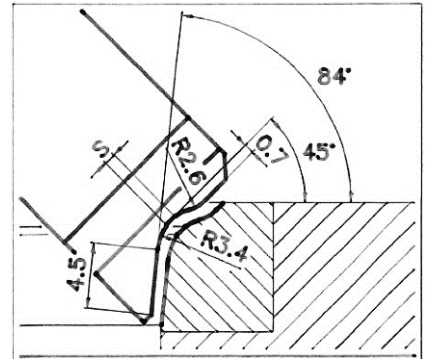

4141 S=0.8mm

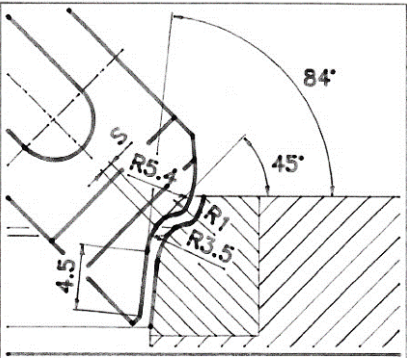

4142 S=0.8mm

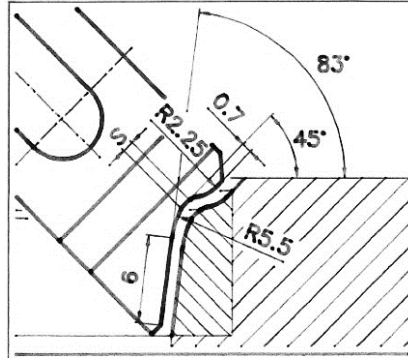

4143 S=0.8mm

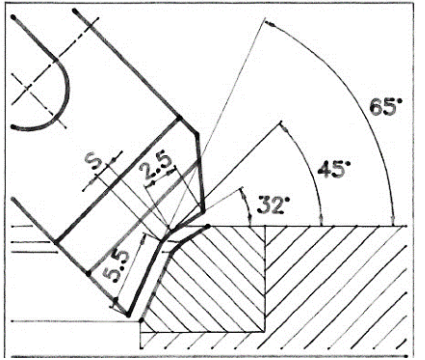

4182 S=0.8mm

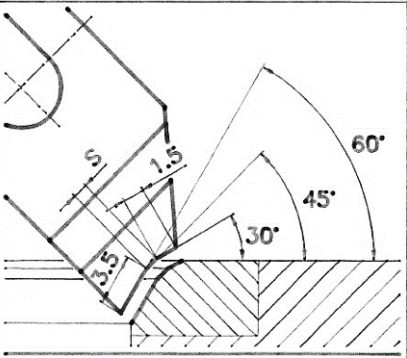

4231 S=0.8mm

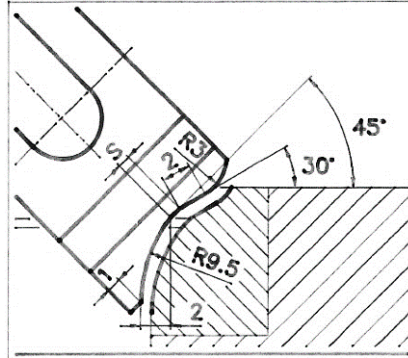

4229 S=0.85mm

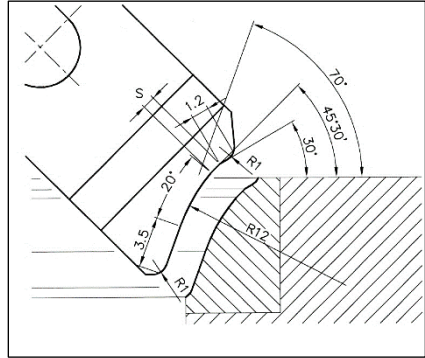

4444 S=0.85mm

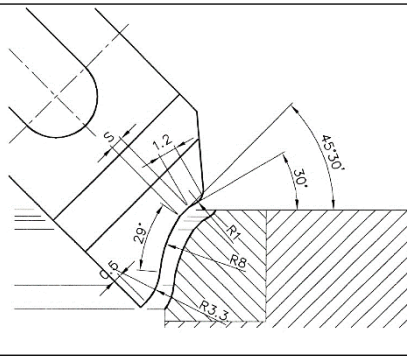

4460 S=0.85mm

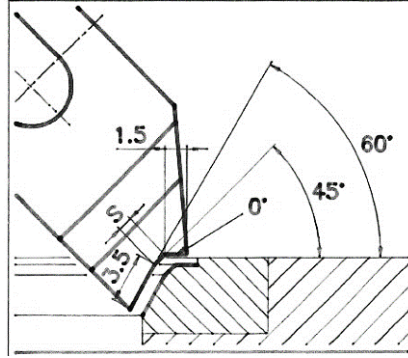

4001 S=1.0mm

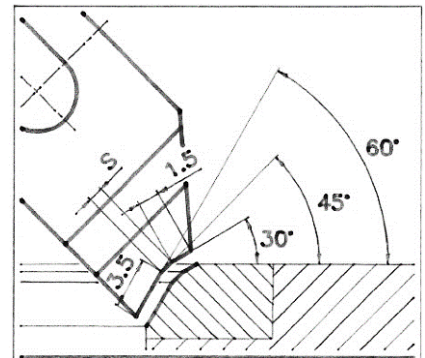

4004 S=1.0mm

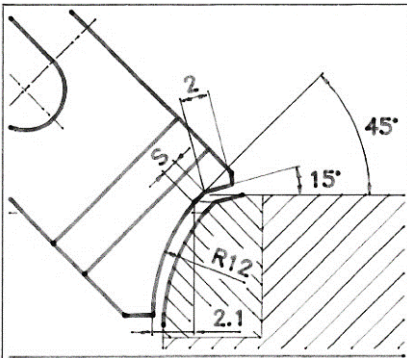

4029 S=1.0mm

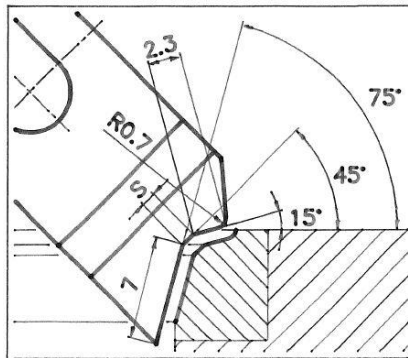

4032 S=1.0mm

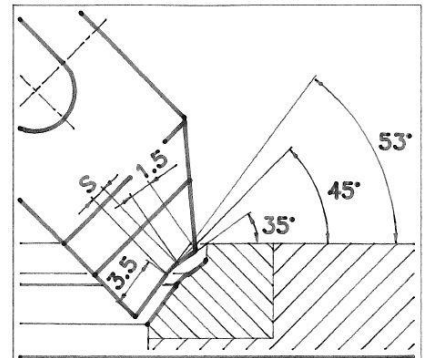

4037 S=1.0mm

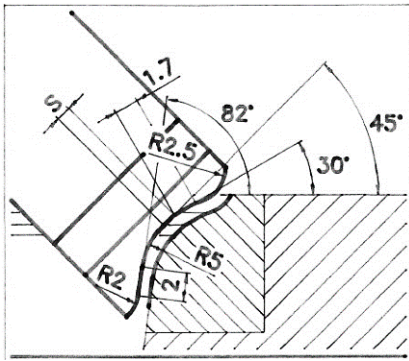

4041 S=1.0mm

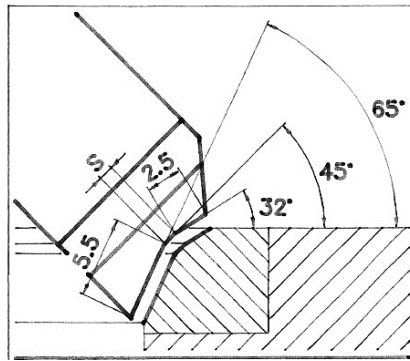

4042 S=1.0mm

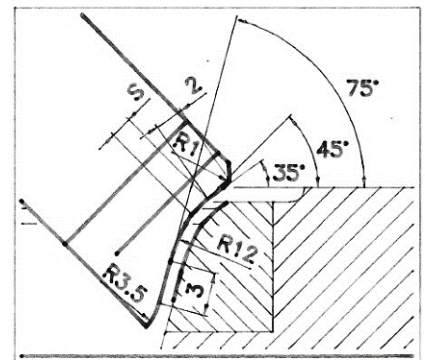

4043 S=1.0mm

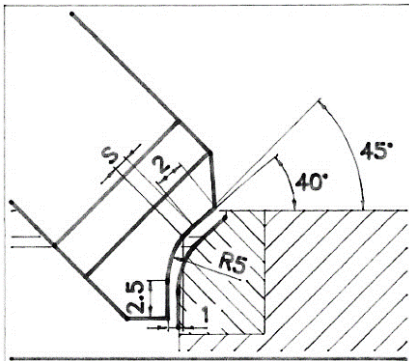

4045 S=1.0mm

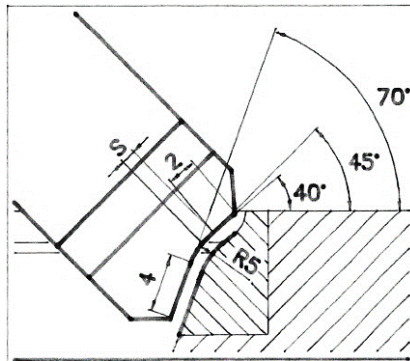

4046 S=1.0mm

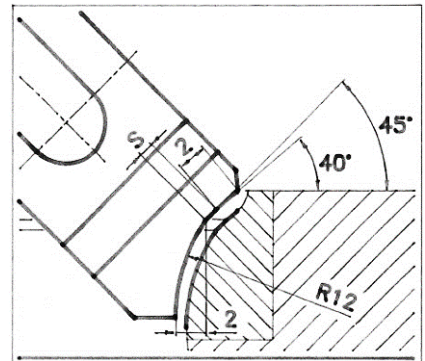

4047 S=1.0mm

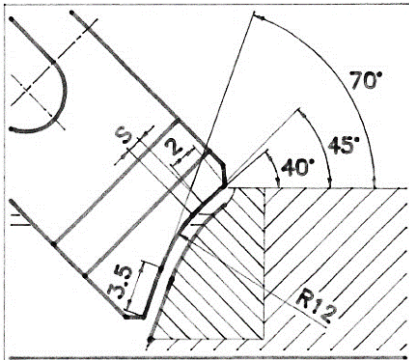

4048 S=1.0mm

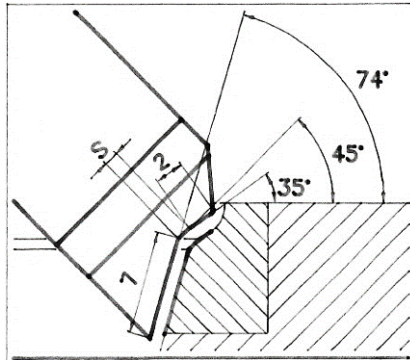

4050 S=1.0mm

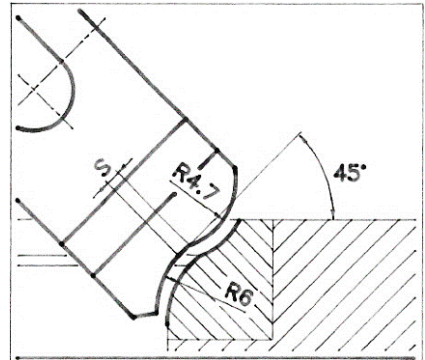

4063 S=1.0mm

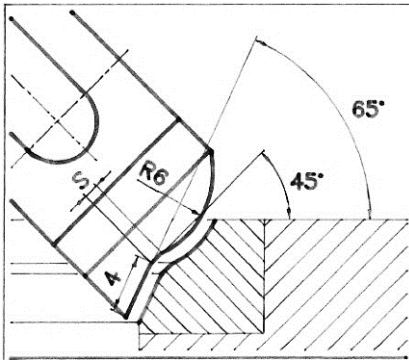

4086 S=1.0mm

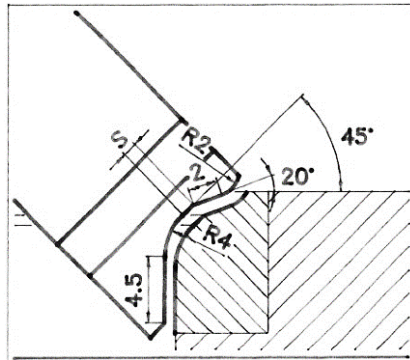

4095 S=1.0mm

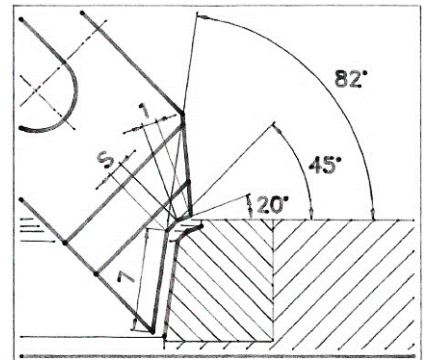

4135 S=1.0mm

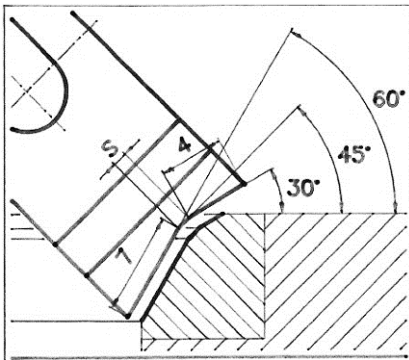

4144 S=1.0mm

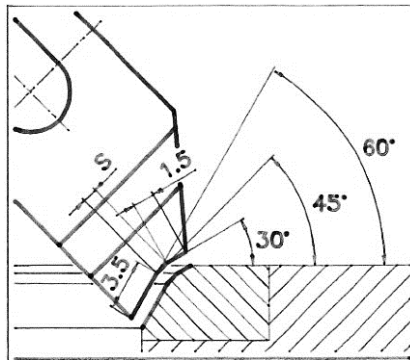

4232 S=1.0mm

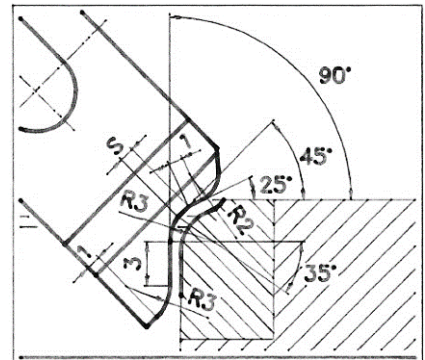

4248 S=1.0mm

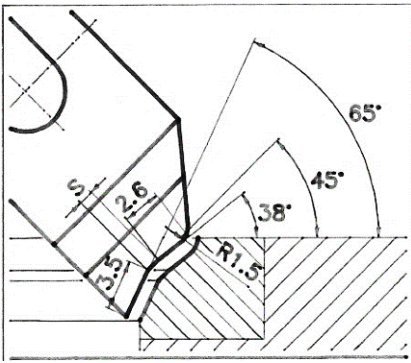

4268 S=1.0mm

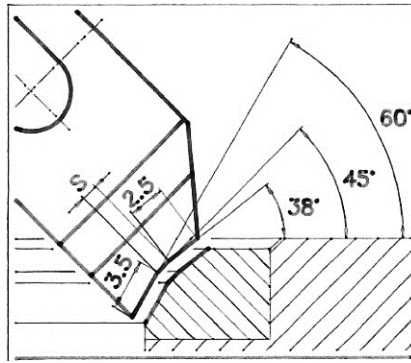

4102 S=1.1mm

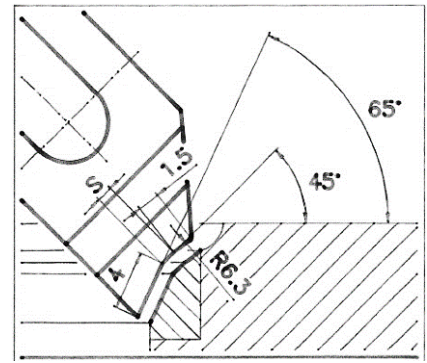

4131 S=1.1mm

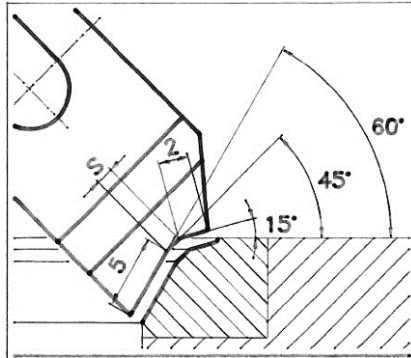

4036 S=1.2mm

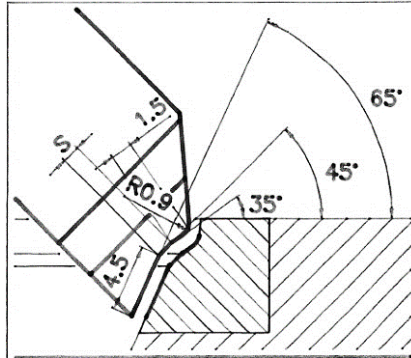

4065 S=1.2mm

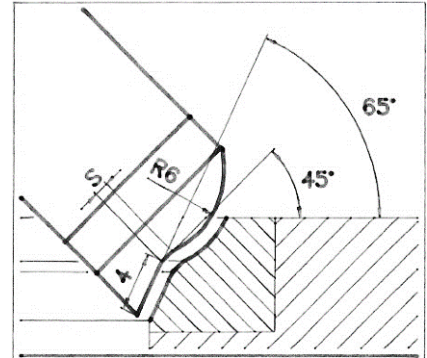

4087 S=1.2mm

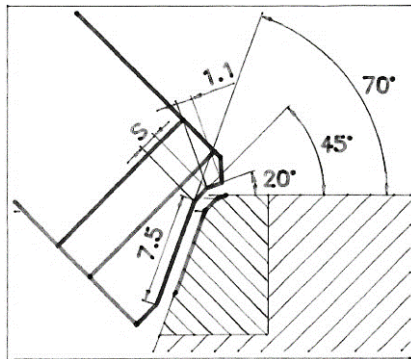

4094 S=1.2mm

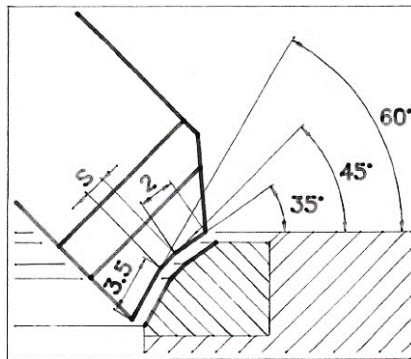

4101 S=1.2mm

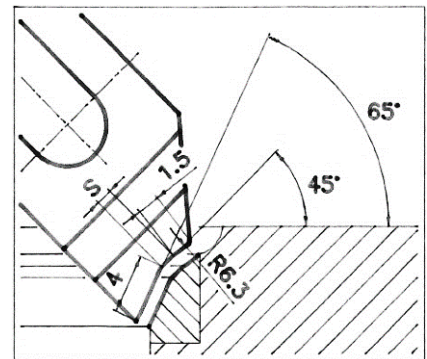

4132 S=1.2mm

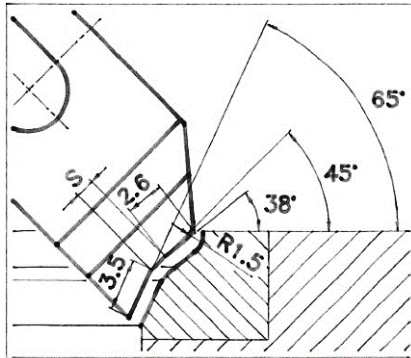

4030 S=1.3mm

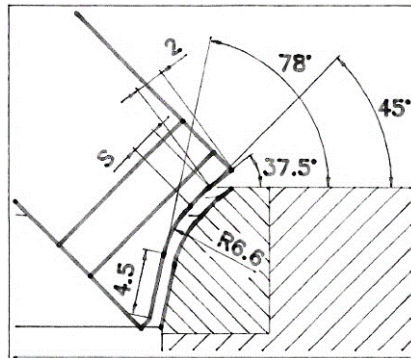

4076 S=1.3mm

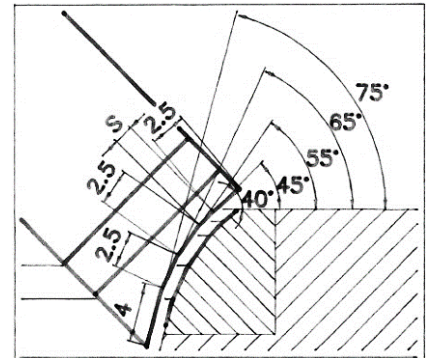

4077 S=1.3mm

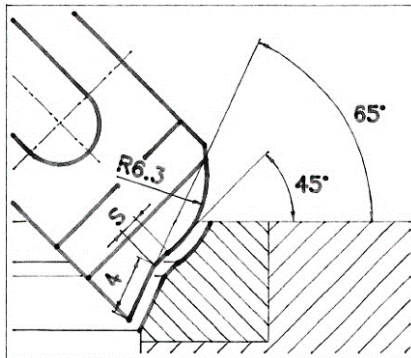

4090 S=1.3mm

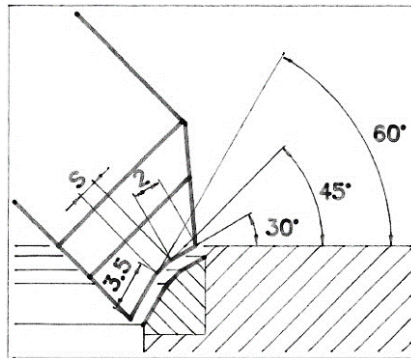

4099 S=1.3mm

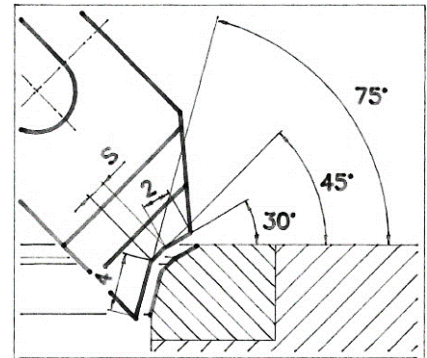

4147 S=1.3mm

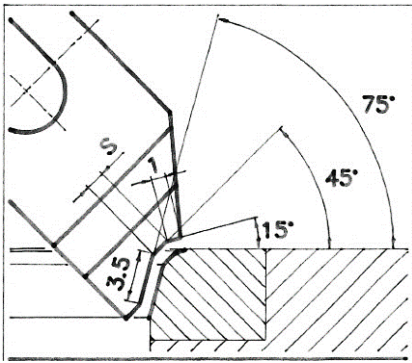

4148 S=1.3mm

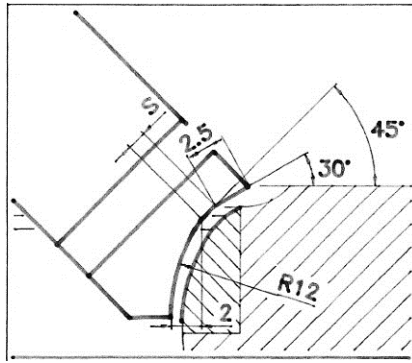

4157 S=1.3mm

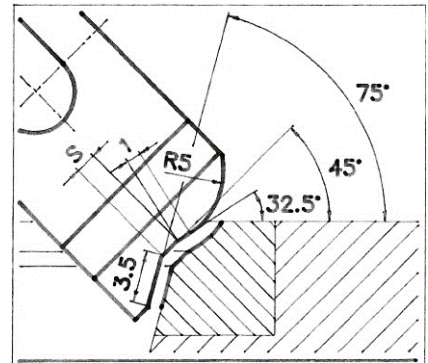

4060 S=1.4mm

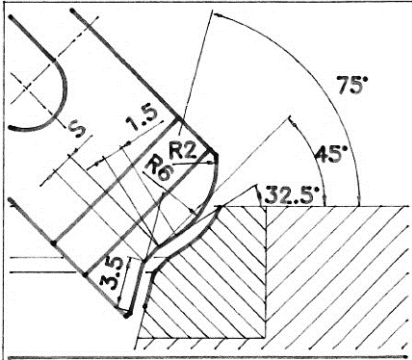

4061 S=1.4mm

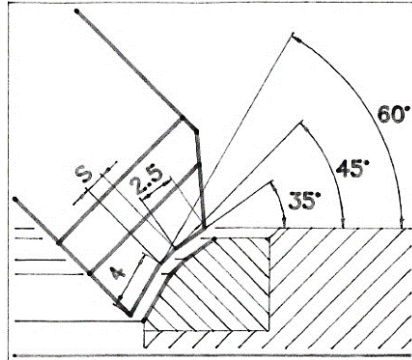

4100 S=1.4mm

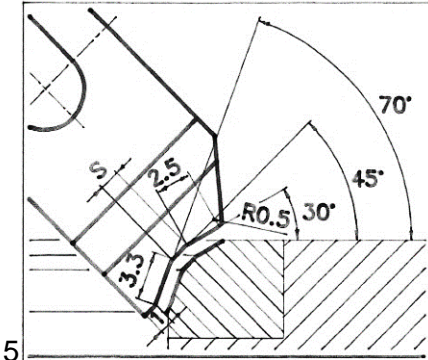

4203 S=1.4mm

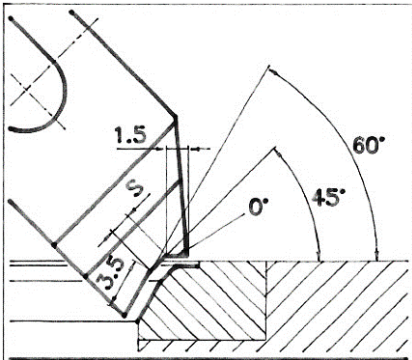

4002 S=1.5mm

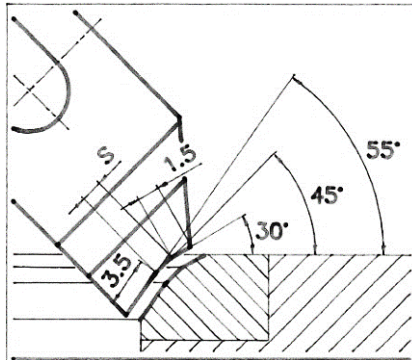

4005 S=1.5mm

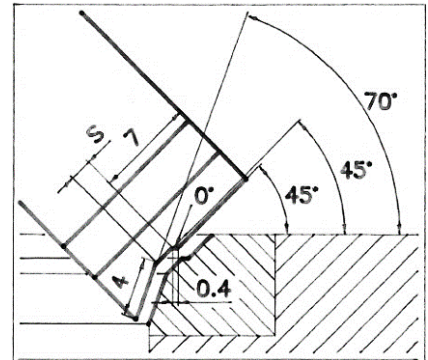

4018 S=1.5mm

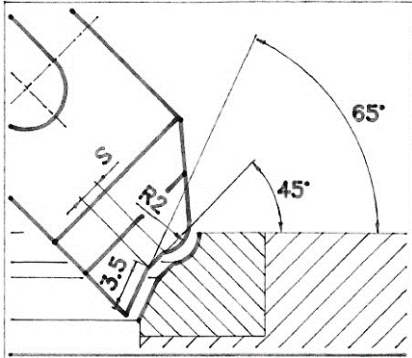

4020 S=1.5mm

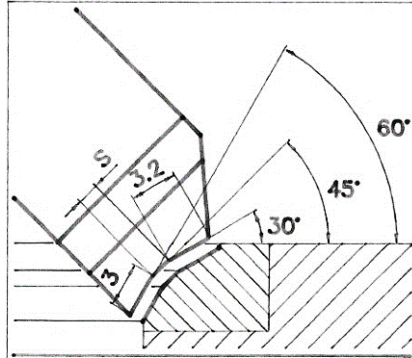

4033 S=1.5mm

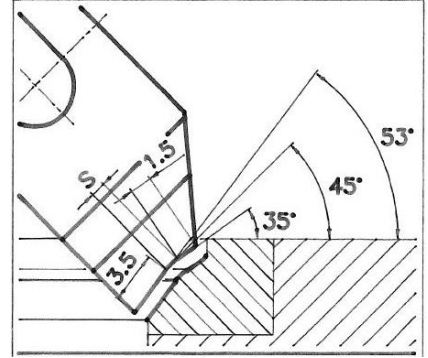

4038 S=1.5mm

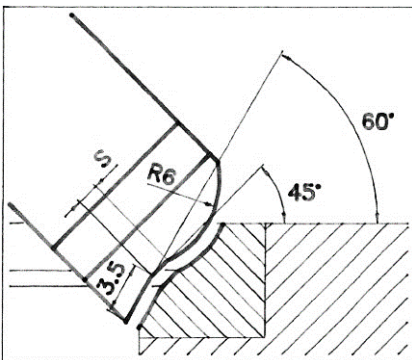

4052 S=1.5mm

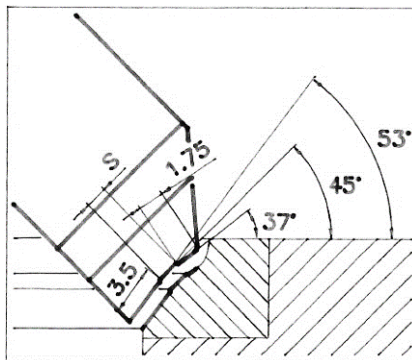

4053 S=1.5mm

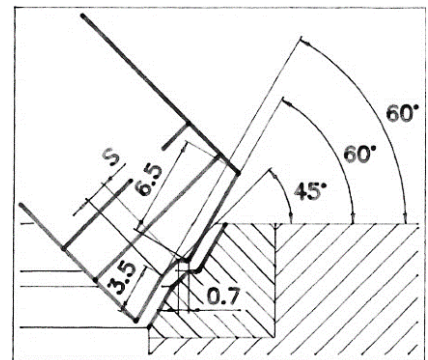

4058 S=1.5mm

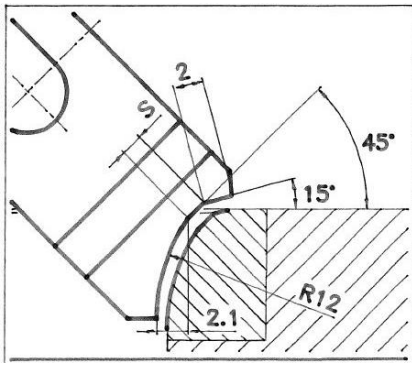

4074 S=1.5mm

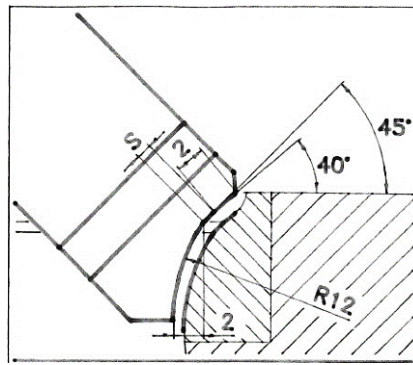

4098 S=1.5mm

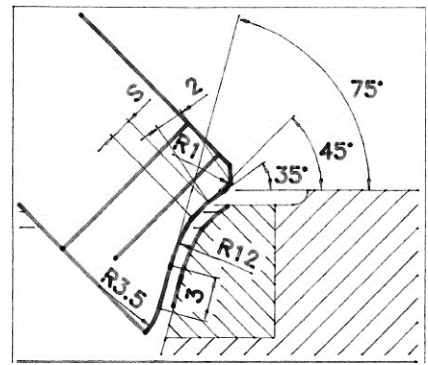

4104 S=1.5mm

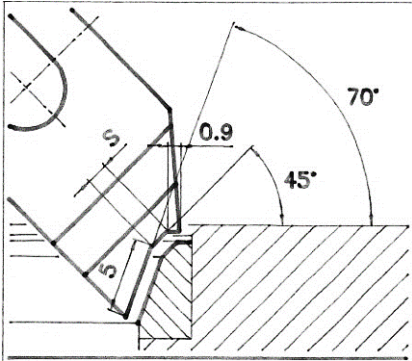

4109 S=1.5mm

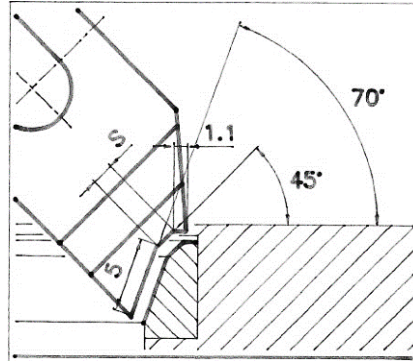

4112 S=1.5mm

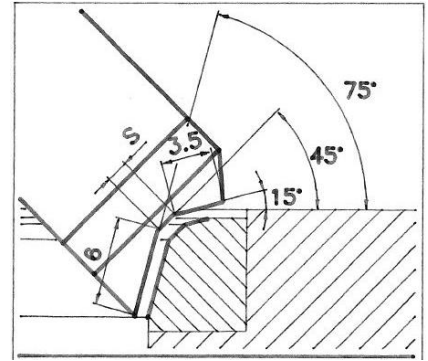

4122 S=1.5mm

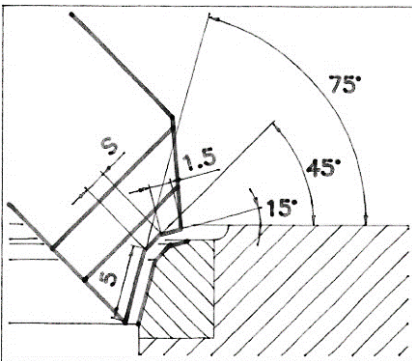

4129 S=1.5mm

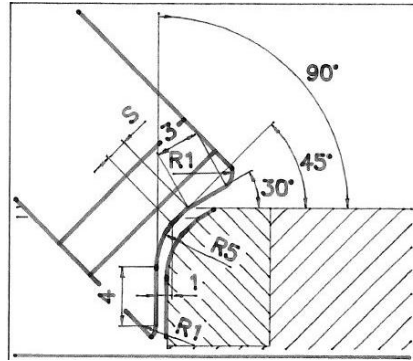

4138 S=1.5mm

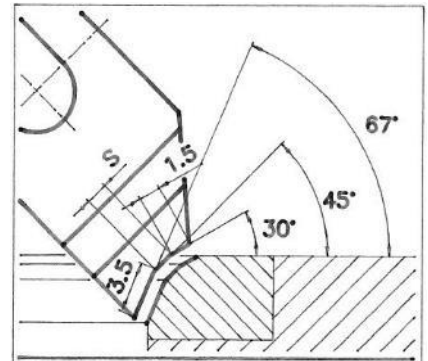

4243 S=1.5mm

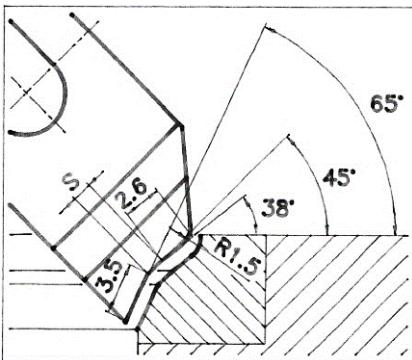

4254 S=1.5mm

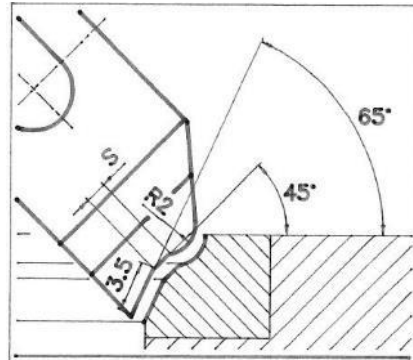

4021 S=1.7mm

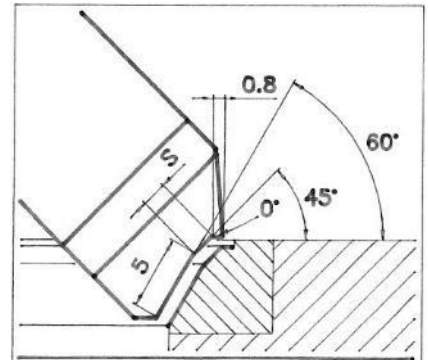

4022 S=1.7mm

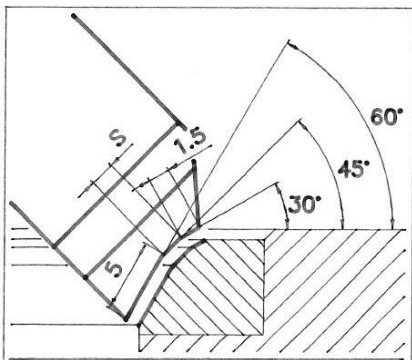

4140 S=1.7mm

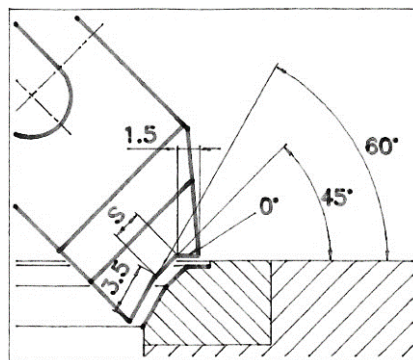

4003 S=2.0mm

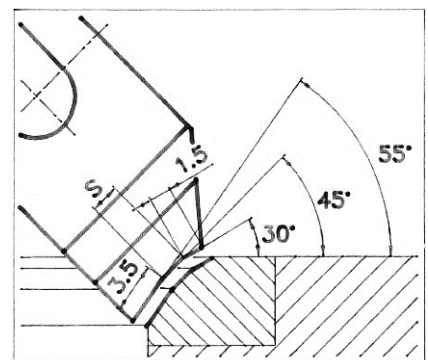

4006 S=2.0mm

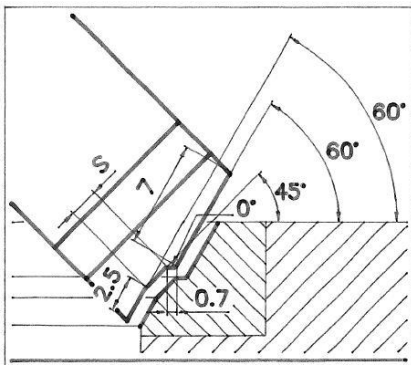

4012 S=2.0mm

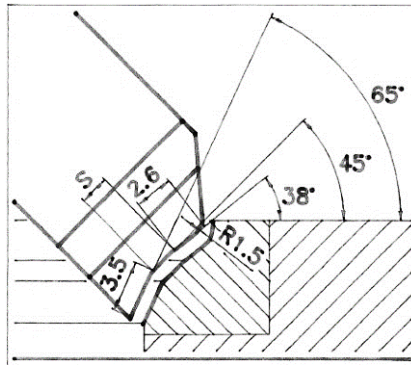

4025 S=2.0mm

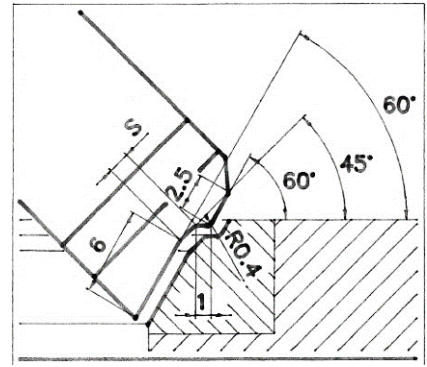

4027 S=2.0mm

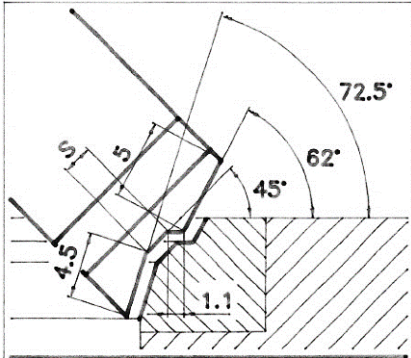

4034 S=2.0mm

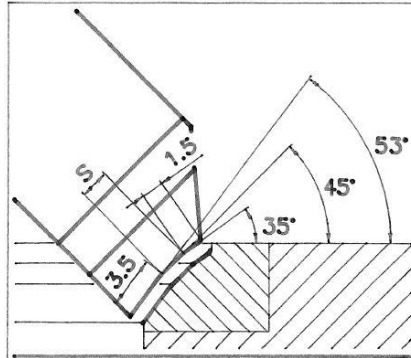

4039 S=2.0mm

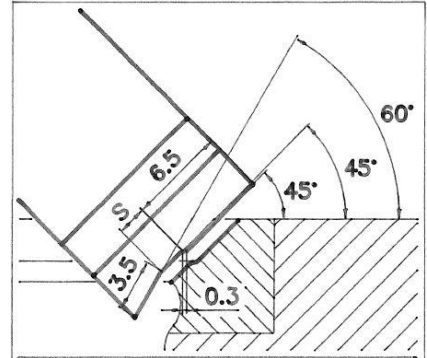

4080 S=2.0mm

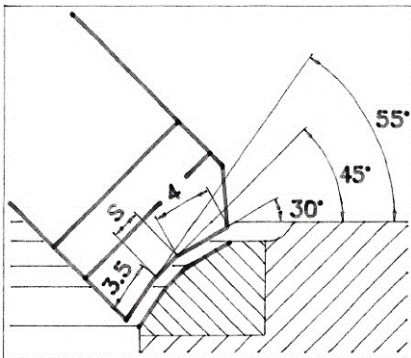

4081 S=2.0mm

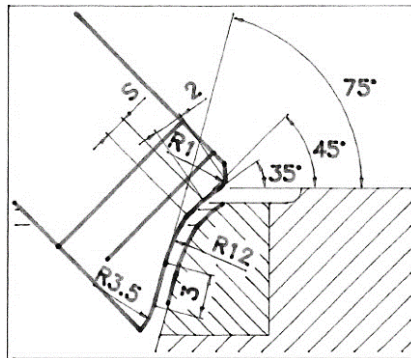

4105 S=2.0mm

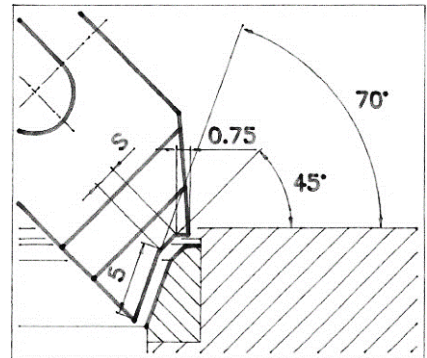

4110 S=2.0mm

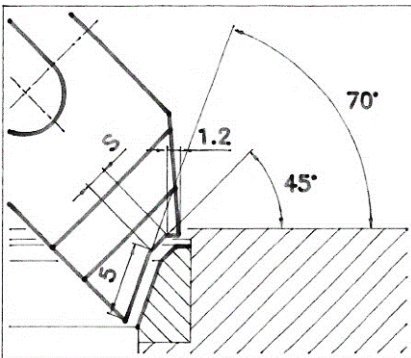

4111 S=2.0mm

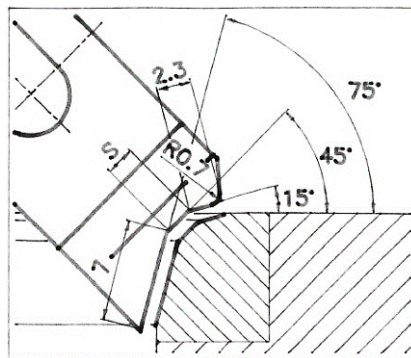

4121 S=2.0mm

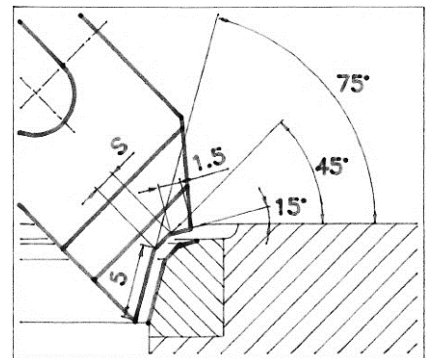

4130 S=2.0mm

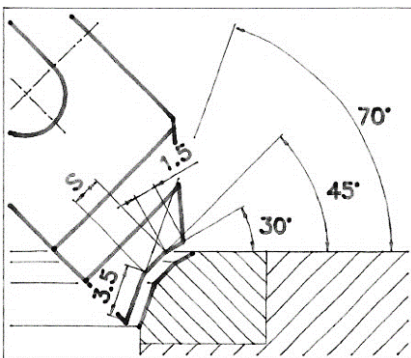

4187 S=2.0mm

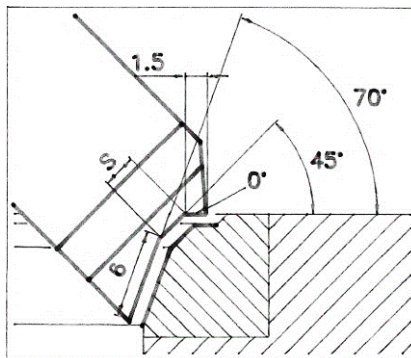

4096 S=2.3mm

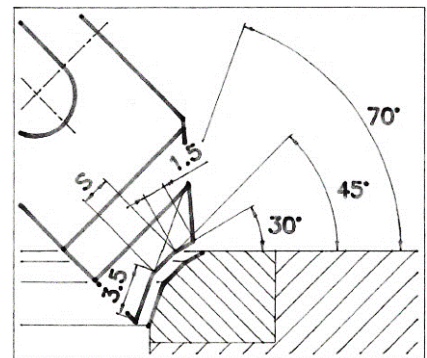

4188 S=2.4mm



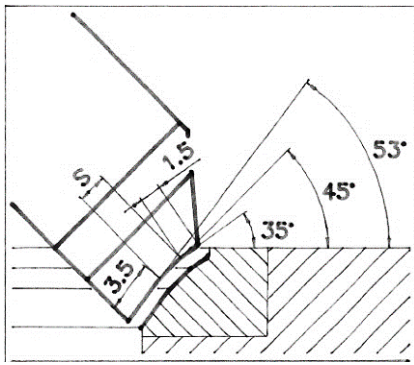

4040 S=2.5mm

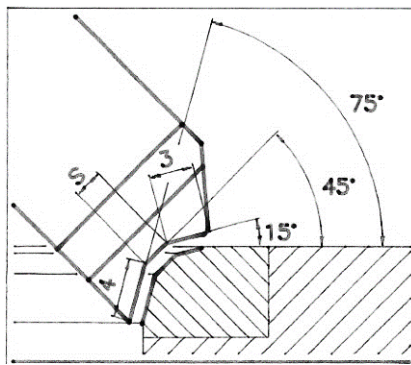

4107 S=2.5mm

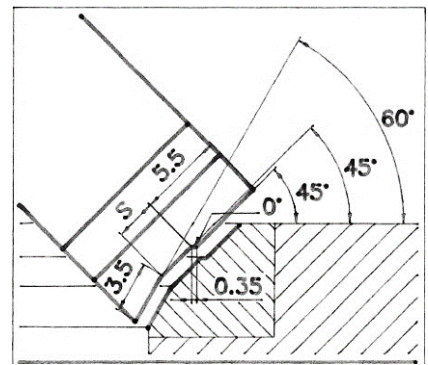

4011 S=2.8mm

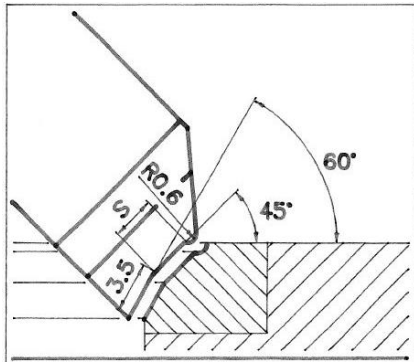

4015 S=3.0mm

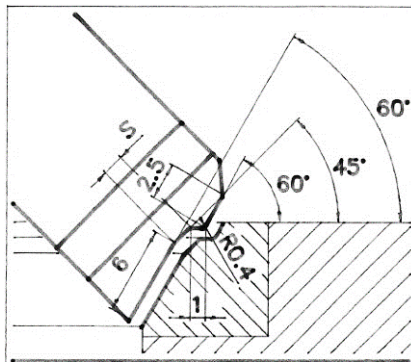

4028 S=3.0mm

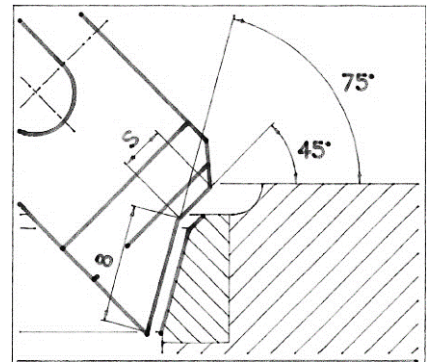

4091 S=3.0mm

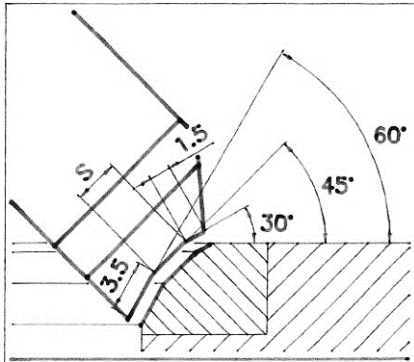

4093 S=3.0mm

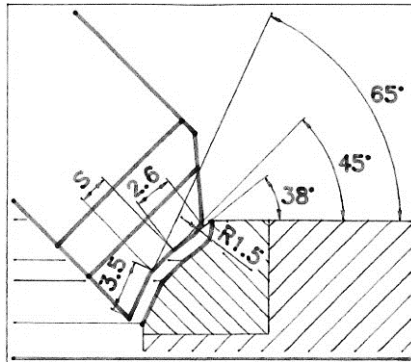

4139 S=3.0mm

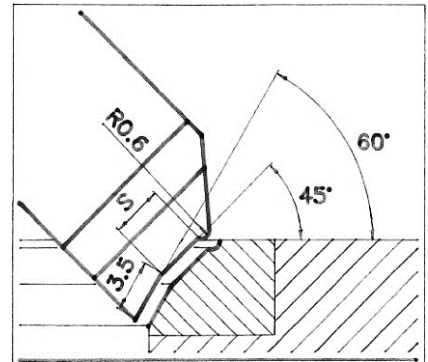

4016 S=3.5mm

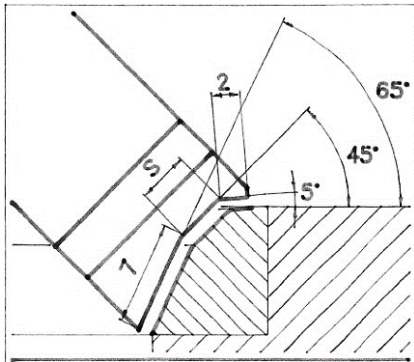

4150 S=3.5mm

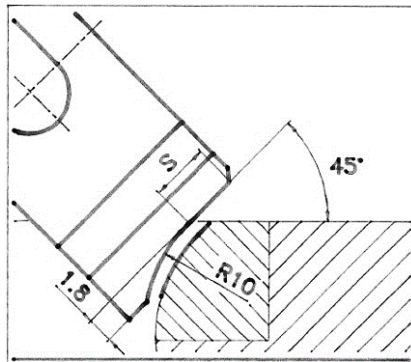

4092 S=4.0mm

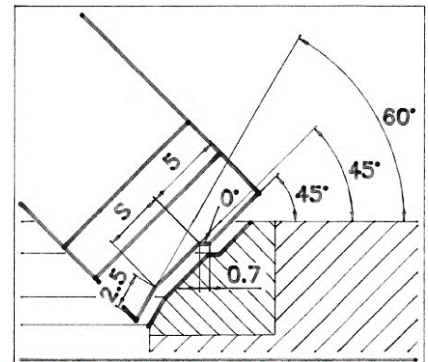

4011 S=4.2mm

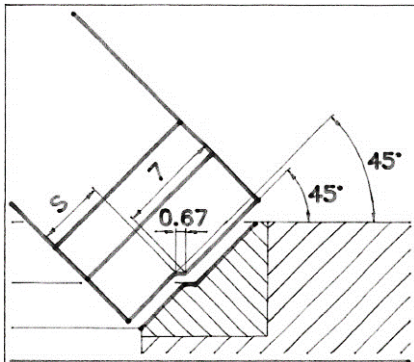

4158 S=4.5mm

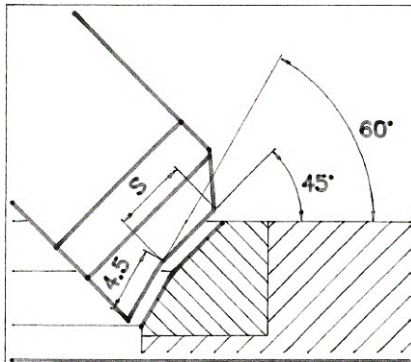

4023 S=5.0mm

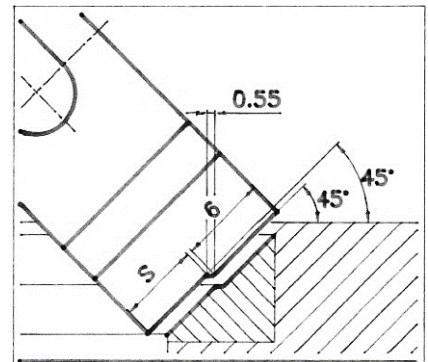

4159 S=5.5mm

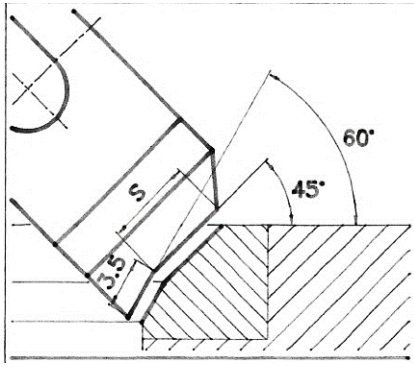

4009 S=6.0mm

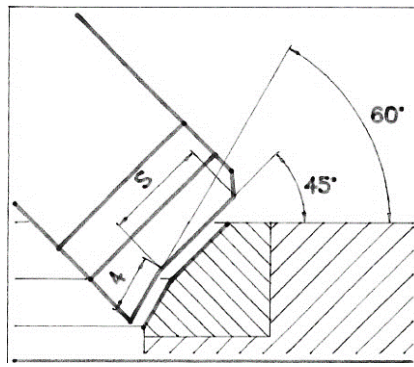

4072 S=7.0mm

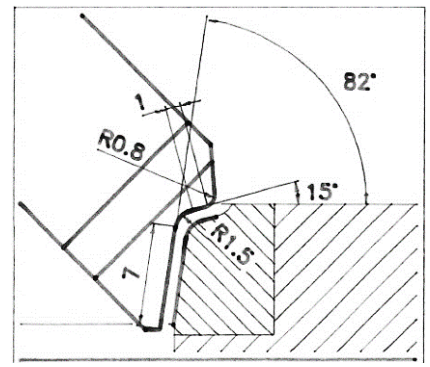

4136

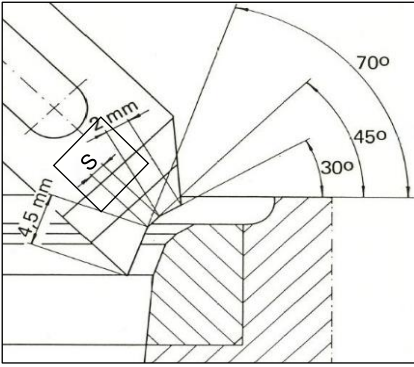

4120 S=1.2mm

- 10 Standard Formtool 30°
- 10 Standard-Formstähle 30°
- 10 *Outils de façon standard 30°*
- 10 *Standard skärstål 30°*
- 10 Utensili ad angolazione multipla standard 30°
- 10 *Cuchillas de mandrinado moldeada standard 30°*

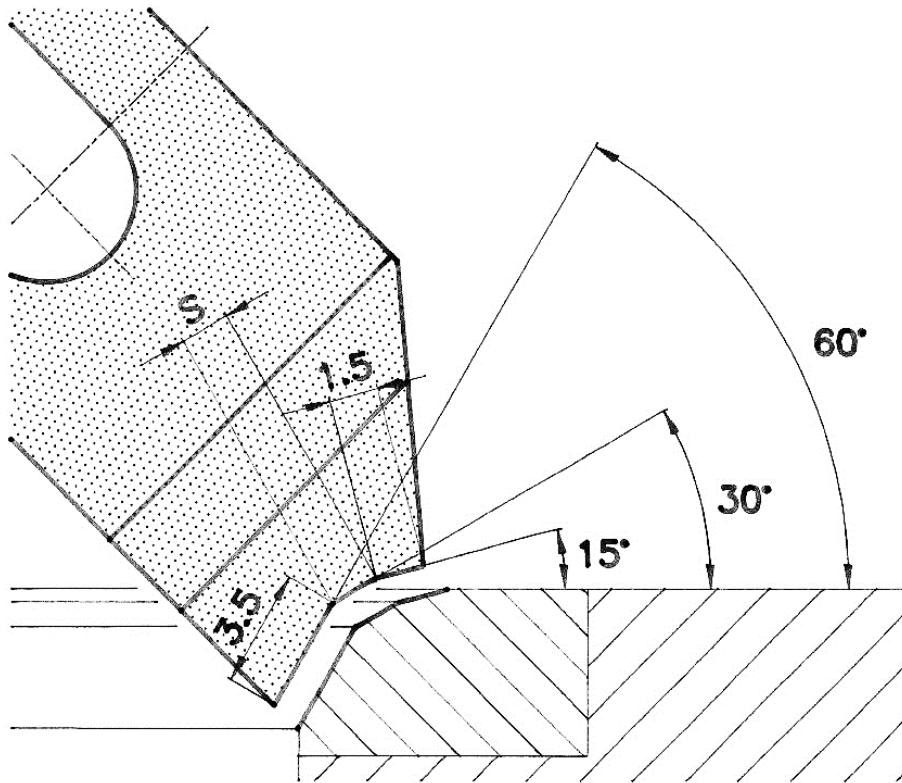

mira reference	Seat width	Seat angle
215A 1.5/30°	1.5	30°30'
220A 2.0/45°	2.0	30°30'
225B 2.5/45°	2.5	30°30'

- 11 Formtools 30°
- 11 Formstähle 30°
- 11 Outils de façon 30°
- 11 Skärstål 30°
- 11 Utensili ad angolazione multipla 30°
- 11 Cuchillas de mandrinado moldeada 30°

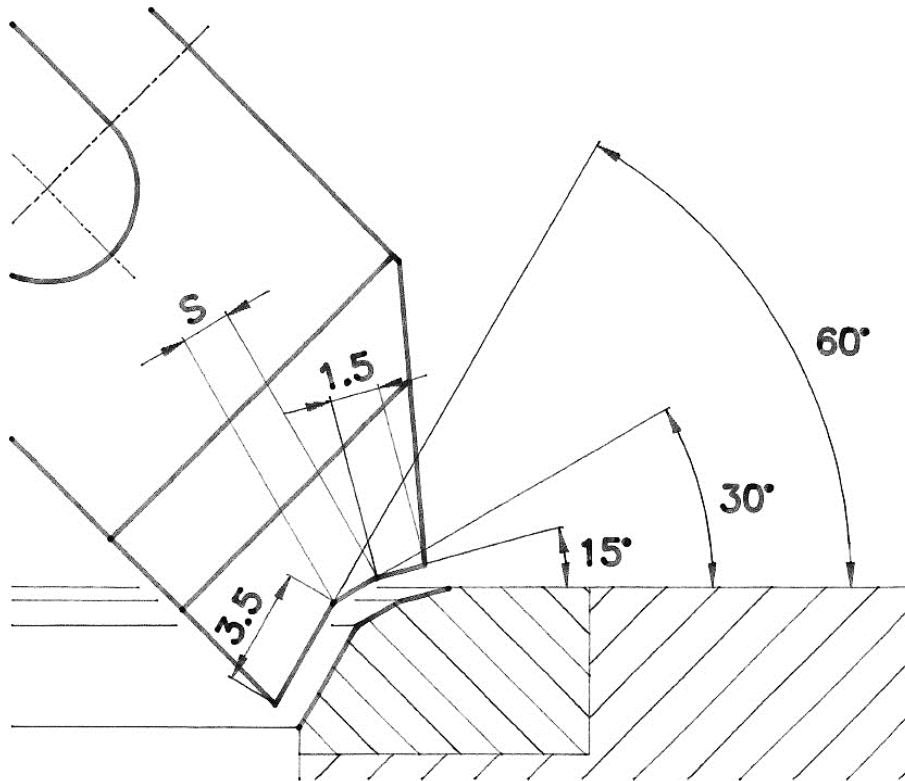

mira reference	Seat width	Seat angle
208C	0.8/30°	0.8 30°30'
210A	1.0/30°	1.0 30°30'
210AX	1.0/30°	1.0 30°30'
210B	1.0/30°	1.0 30°30'
210BX	1.0/30°	1.0 30°30'
210C	1.0/30°	1.0 30°30'
212B	1.2/30°	1.2 30°30'
215AX	1.5/30°	1.5 30°30'
215B	1.5/30°	1.5 30°30'
215BX	1.5/30°	1.5 30°30'
215C	1.5/30°	1.5 30°30'

mira reference	Seat width	Seat angle
220AX	2.0/30°	2.0 30°30'
220B	2.0/30°	2.0 30°30'
220BX	2.0/30°	2.0 30°30'
220DT	2.0/30°	2.0 30°30'
225BX	2.5/30°	2.5 30°30'
225DT	2.5/30°	2.5 30°30'
230B	3.0/30°	3.0 30°30'
230BX	3.0/30°	3.0 30°30'
230DT	3.0/30°	3.0 30°30'
235B	3.5/30°	3.5 30°30'
240B	4.0/30°	4.0 30°30'

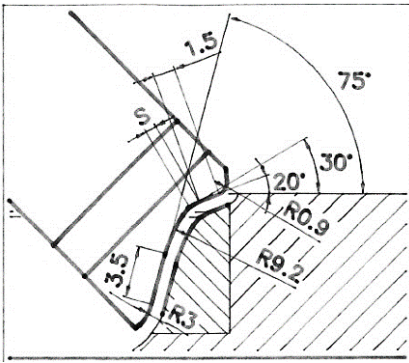

4520 S=0.75mm

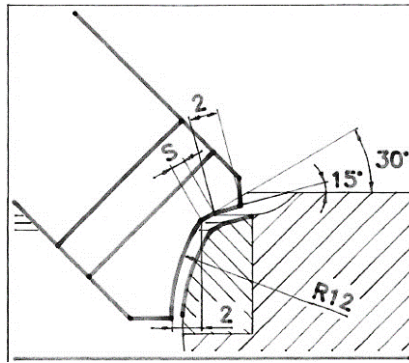

4510 S=1.0mm

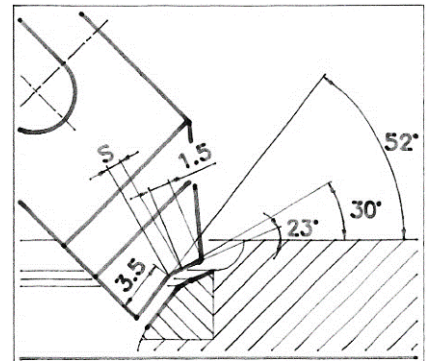

4514 S=1.0mm

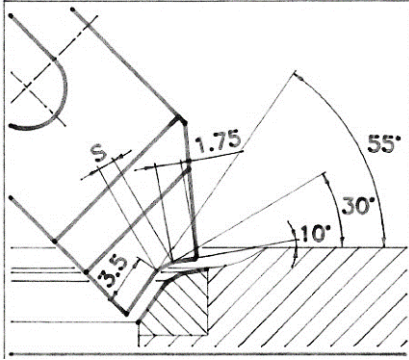

4518 S=1.2mm

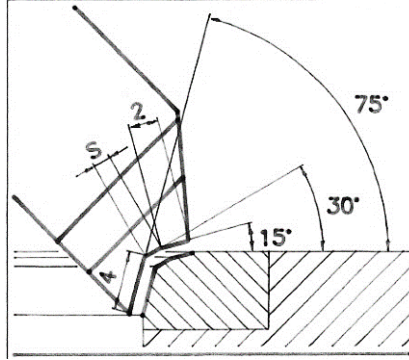

4530 S=1.2mm

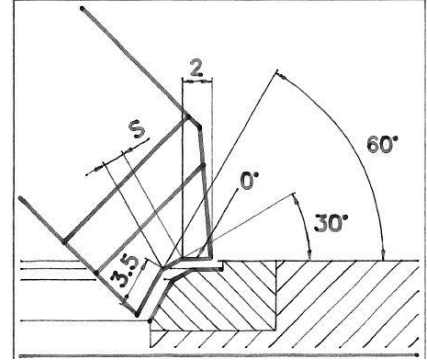

4504 S=1.5mm

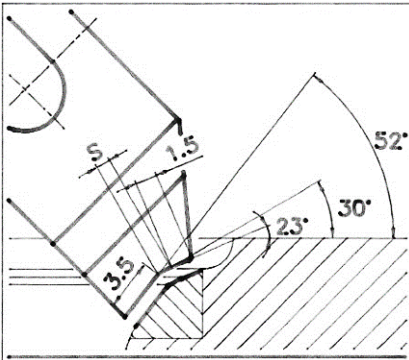

4515 S=1.5mm

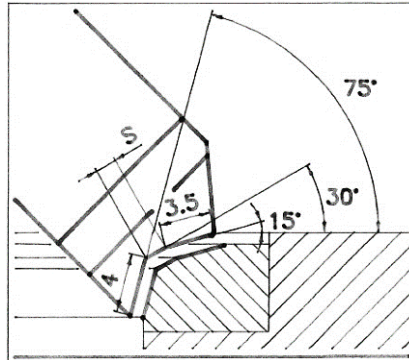

4543 S=1.5mm

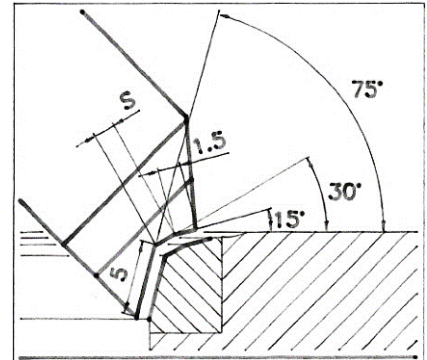

4547 S=1.5mm

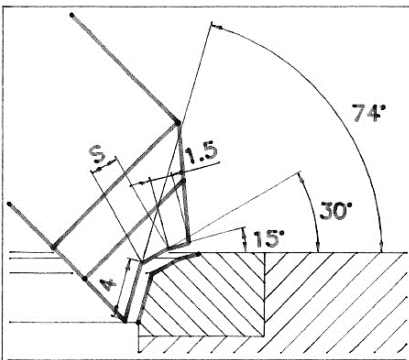

4502 S=2.0mm

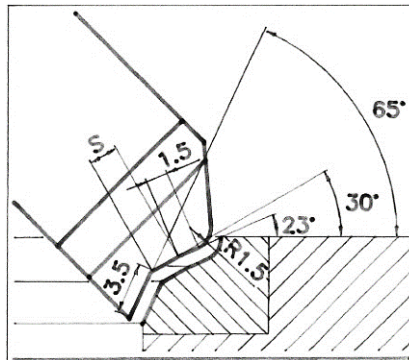

4509 S=2.0mm

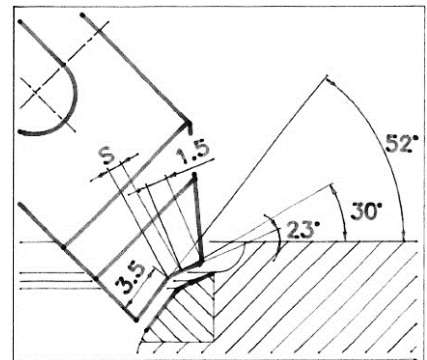

4516 S=2.0mm

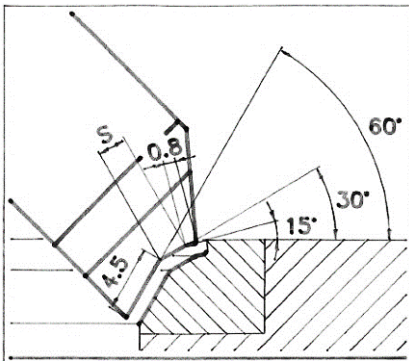

4525 S=2.0mm

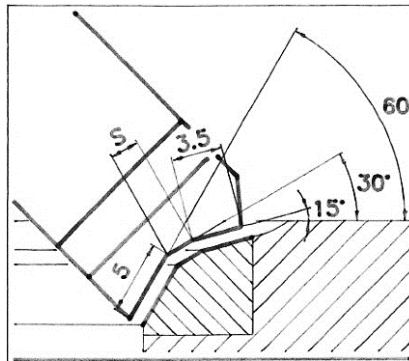

4526 S=2.0mm

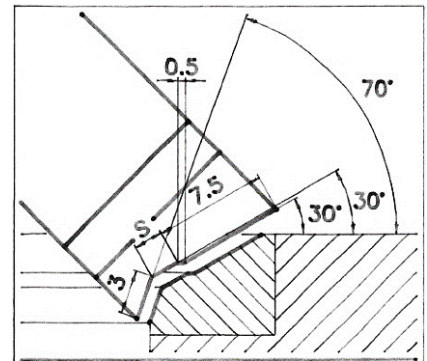

4538 S=2.0mm

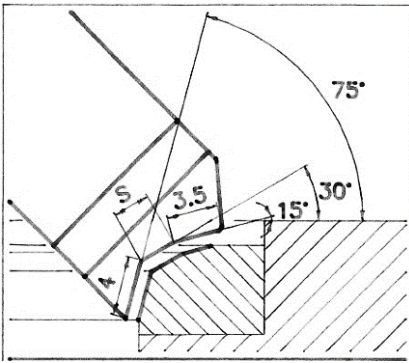

4512 S=2.5mm

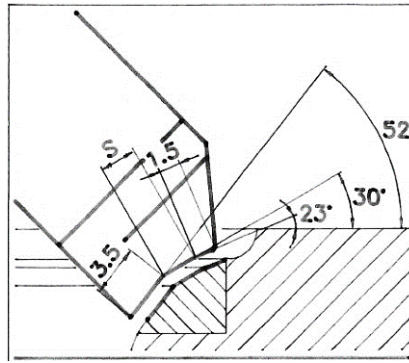

4517 S=2.5mm

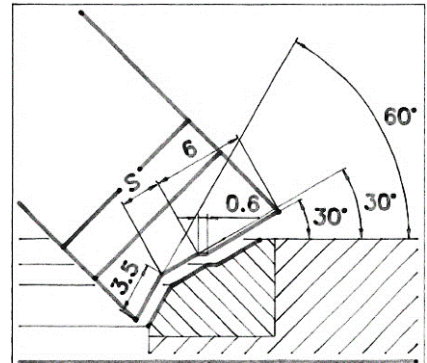

4539 S=2.8mm

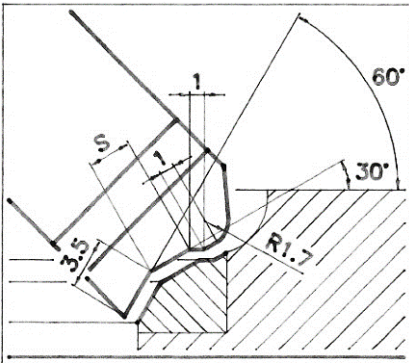

4519 S=3.0mm

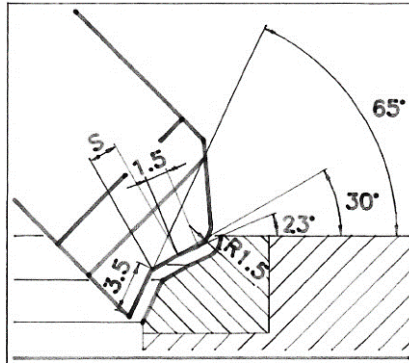

4549 S=3.0mm

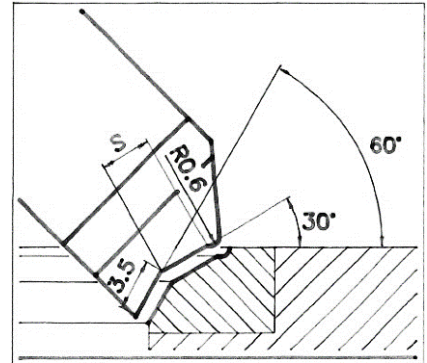

4506 S=3.5mm

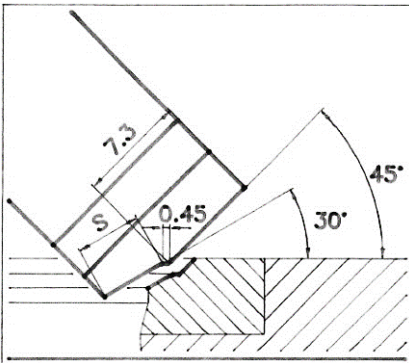

4557 S=4.5mm

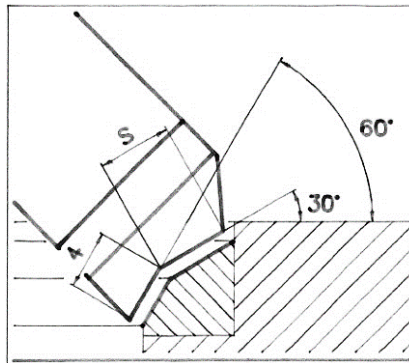

4535 S=5.0mm

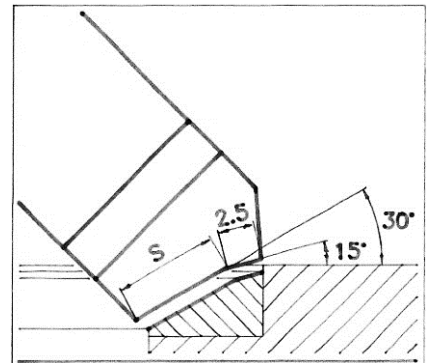

4531 S=7.0mm

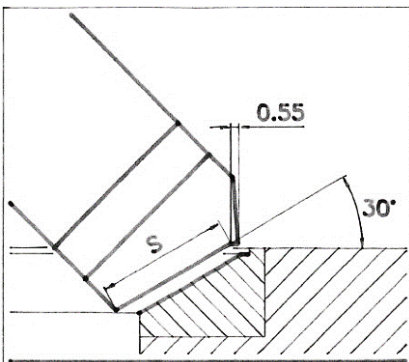

4567 S=9.0mm

- 12 Formtools 20°
- 12 Formstähle 20°
- 12 Outils de façon 20°
- 12 Skärstål 20°
- 12 Utensili ad angolazione multipla 20°
- 12 Cuchillas de mandrinado moldeada 20°

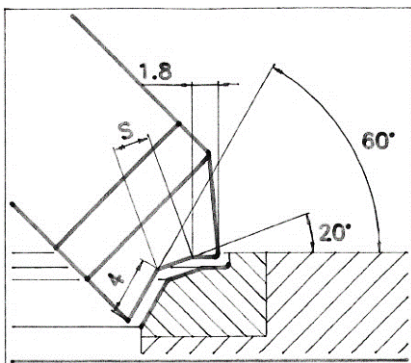

4524 S=2.0mm

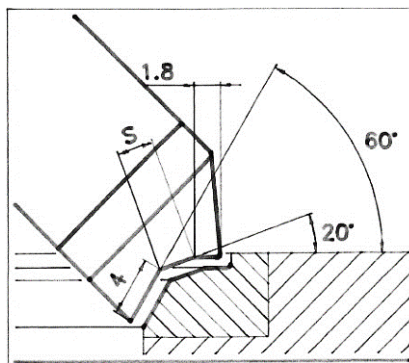

4523 S=2.5mm

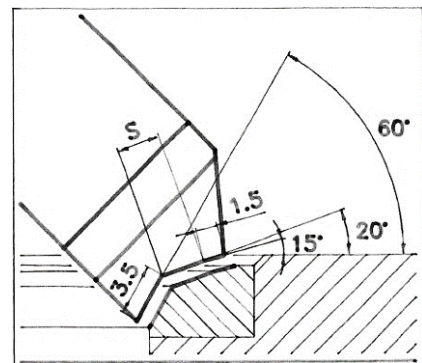

4552 S=3.0mm

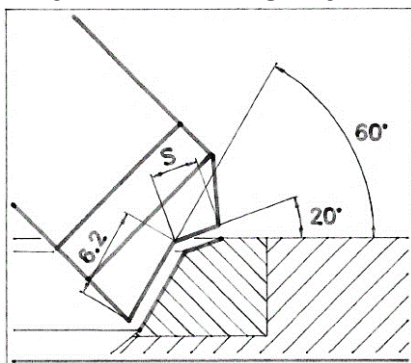

4544 S=3.25mm

- 13 Formtools 35°/ 38°**
- 13 Formstähle 35°/ 38°**
- 13 Outils de façon 35°/ 38°**
- 13 Skärstål 35°/ 38°**
- 13 Utensili ad angolazione multipla 35°/ 38°**
- 13 Cuchillas de mandrinado moldeada 35°/ 38°**

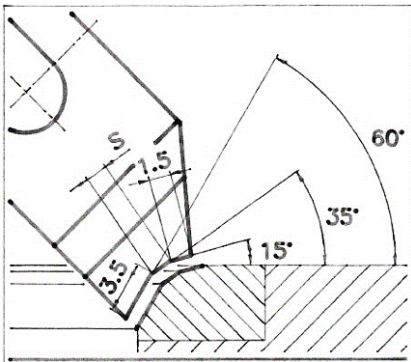

4529 S=1.5mm

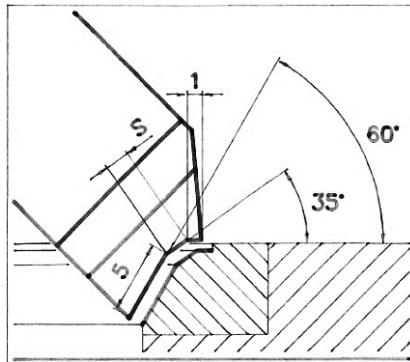

4508 S=1.7mm

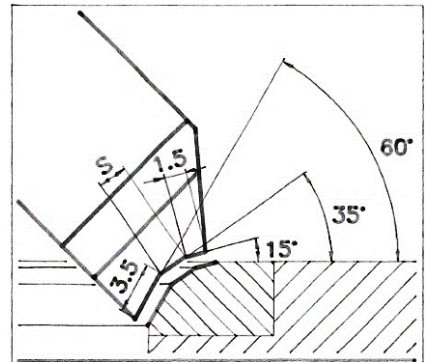

4503 S=2.0mm

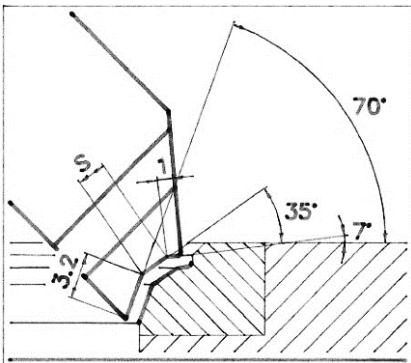

4542 S=2.0mm

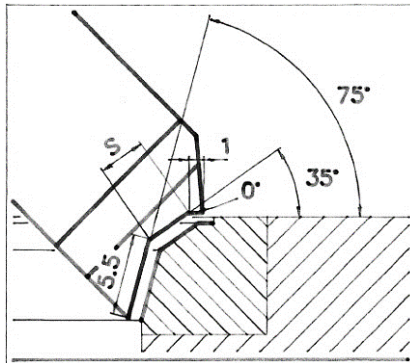

4507 S=3.2mm

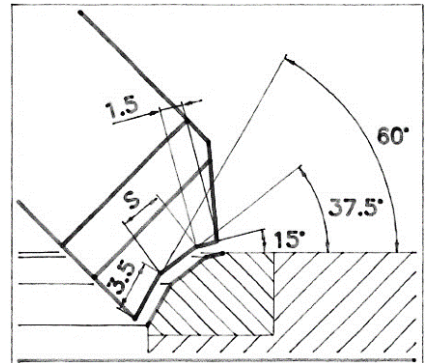

4558 S=2.0mm

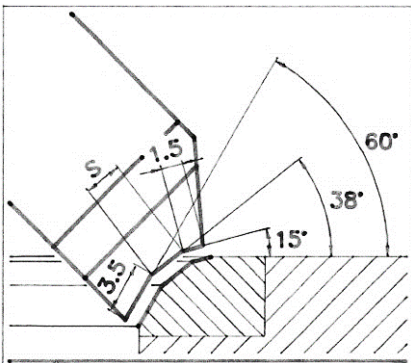

4505 S=2.6mm



- 14 Formtools for corrections
- 14 Formstähle für Korrekturen
- 14 Outils de façon pour dégagements
- 14 Skärstål för reducering
- 14 Utensili ad angolazione multipla per correzioni
- 14 Buriles para correcciones

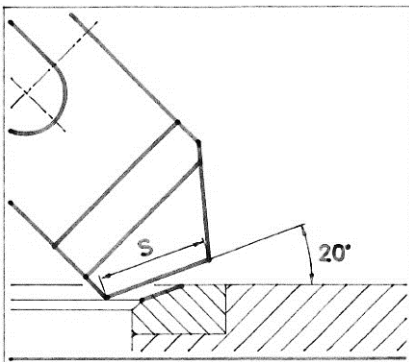

306 S=7.5mm

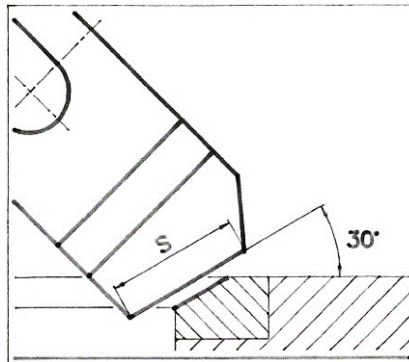

302 S=9.0mm

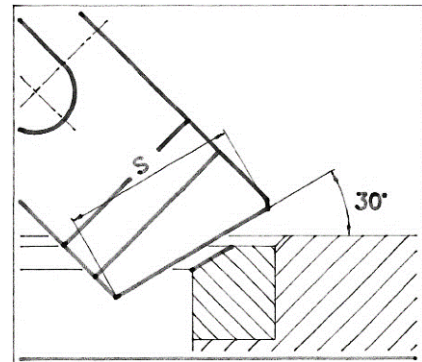

305 S=12.0mm

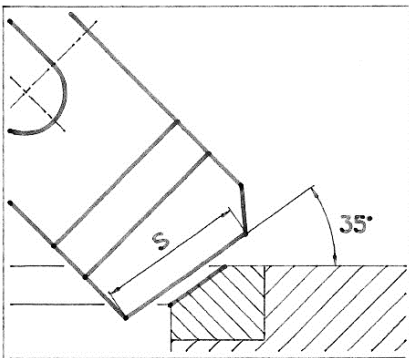

303 S=10.0mm

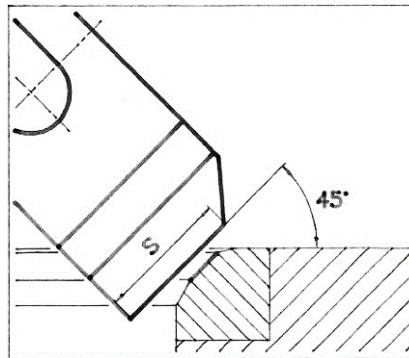

301 S=9.0mm

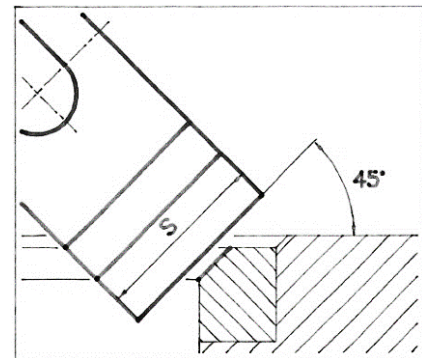

304 S=12.0mm

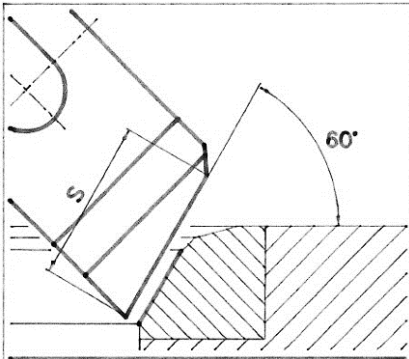

362 S=11.0mm

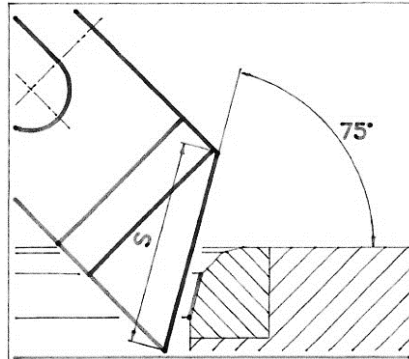

351 S=14.0mm

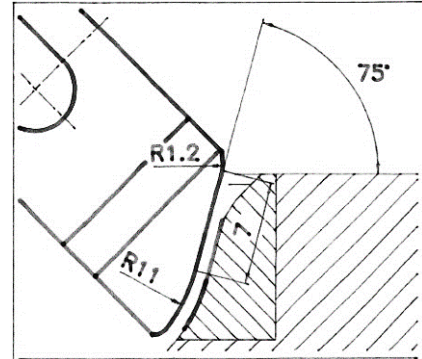

353

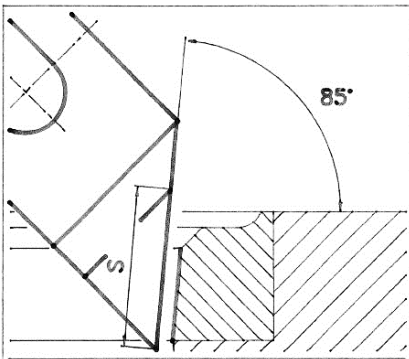

365 S=12.0mm

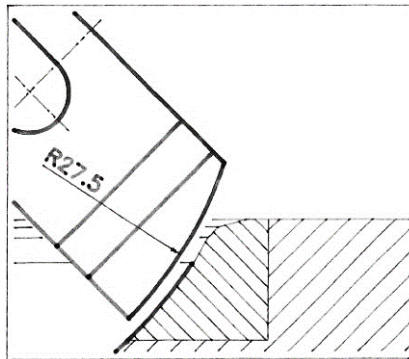

358

- 15 Formtools for corrections and counterbores
- 15 Formstähle für Korrekturen und Ringsitze
- 15 Outils de façon pour dégagements et l'usinage de logements
- 15 Skärstål för reducering och ringsäten
- 15 Utensili ad angolazione multipla per correzioni e per anelli
- 15 Buriles para correcciones y anillos de asiento

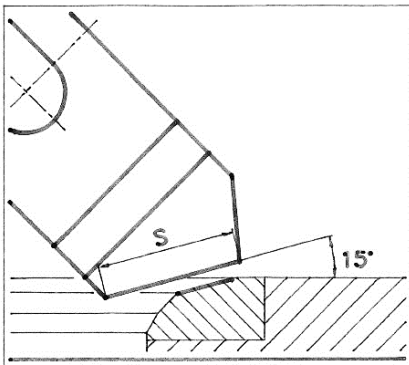

352 S=9.5mm

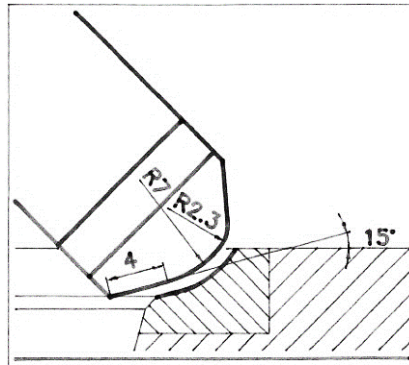

354

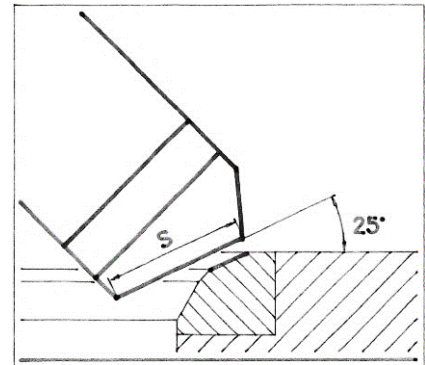

360 S=9.5mm

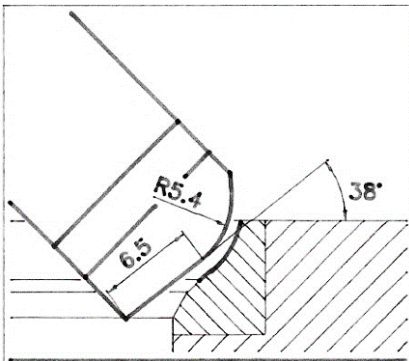

355

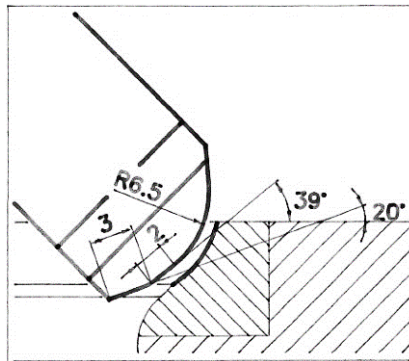

357

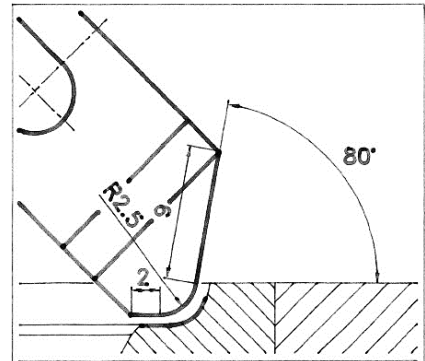

363

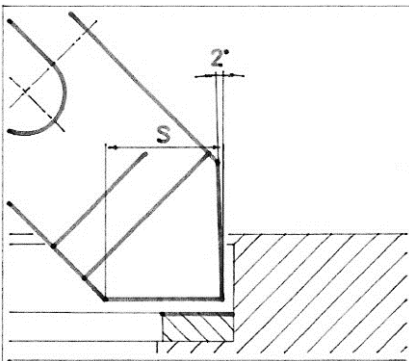

390 S=8.0mm



**Notizen / Notes**

Lined area for notes with horizontal dotted lines.

Alle Angaben sind ohne Gewähr von Richtigkeit und Vollständigkeit.

All information is without guarantee of correctness and completeness.

Toutes les information sont fournies sans garantie d'exactitude et d'exhaustivité.

---

Manufacturer and worldwide distributor:

**MINELLI CORPORATION**  
8330 Pfäffikon ZH  
Switzerland

[www.miratool.ch](http://www.miratool.ch)

Your local dealer:



**fijn**techniek **fij**naart b.v.  
Machines voor motoren revisie,  
honen en ultrasoonreinigen

*Service makes the difference!*

Blaaksedijk 30 | 4793 RN Fijnaart | Nederland  
tel. +31 (0)168 46 44 61 info@ftf.nl www.ftfmachines.com

---