

K-line



**VALVE GUIDE LINERS &
GUIDE LINER TOOLING**

SIMPLE - FAST - ECONOMICAL

#1 REPAIR METHOD FOR ALUMINUM & CAST IRON CYLINDER HEADS

Our leadership in developing new, cost effective ways to repair worn valve guides led to the development of the BRONZE BULLET® INTERRUPTED SPIRAL® GUIDE-LINER® over forty years ago.

Guide-Liner® Benefits:

- Superior Lubricity - Reduces valve stem sticking and galling.
- Oil control - Interrupted Spiral® reduces the possibility of excessive oil consumption.
- Tighter guide-to-stem clearances for improved performance.
- Improved wear characteristics vs. cast iron (see chart).

Bullet nose feature allows for efficient installation without chamfering the guide boss.

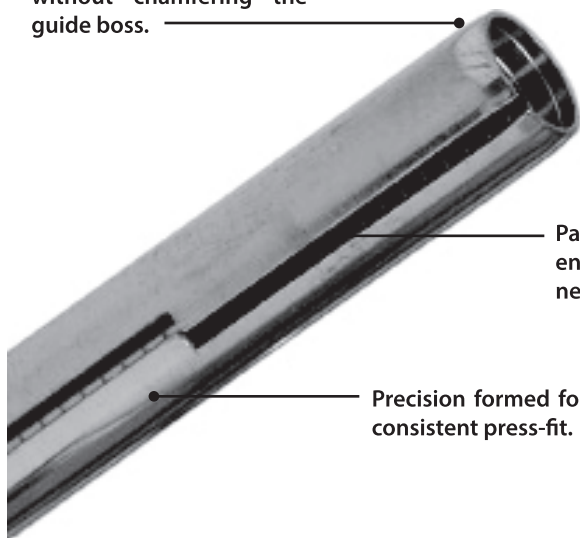

Patented spiral retains engine oil where it's needed.

Precision formed for a consistent press-fit.

Aluminum Cylinder Heads:

- No need to remove original guides.
- No galled or scored guide holes.
- No need for oversize guides.
- Guide-to-seat runout maintained.

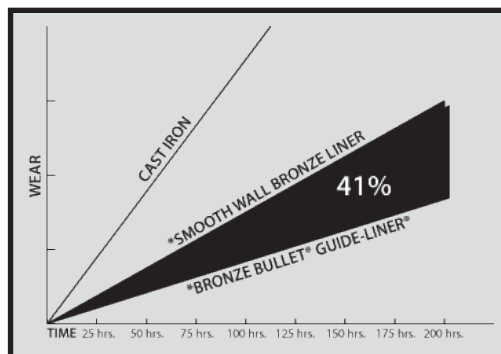

Engine Rebuilder Friendly . . . Easy-To-Install

Install in seconds with the auto-installer. Bronze Bullet® Guide-Liners® eliminate the need to chamfer guide bosses, as well as the expense of having to replace valves or guides. The Interrupted Spiral® provides superior lubrication and oil control.

DON'T SETTLE FOR IMITATIONS!

USE THE ORIGINAL



BRONZE BULLET®

BRONZE BULLET® VALVE GUIDE-LINER® 5-STEP INSTALLATION PROCEDURE

BRONZE BULLET® INSTRUCTIONAL VIDEOSGUIDE-LINER® INSTALLATION

This professionally produced video gives you a detailed look at the proper procedure for installing the K-Line® Bronze Bullet® Valve Guide-Liner® using recommended installation tools and KL9900 Valve Guide Boring Fixture (page 8). DVD. 15 minutes in length. Step-by-step instructions include:

- 1) Boring the valve guide
- 2) Installing the Bronze Bullet®
- 3) I.D. finishing
- 4) Trimming excess
- 5) Flex-Honing

Watch Here:

<http://www.youtube.com/watch?v=xOaOTnpacV0>

STEP 1 BORE

Use a K-Line® Carbide Boring Tool (page 9) with a high RPM (2,100) Air Drill to bore out the original guide. Must use a K-Line® Reamer Bushing (page 9) and K-Line® Valve Seat Bushings (page 6) for proper alignment results. For powdered metal guides, longer life and absolute precision, try a Guide Pro® Solid Carbide Black Beauty® Boring Reamer (page 10).

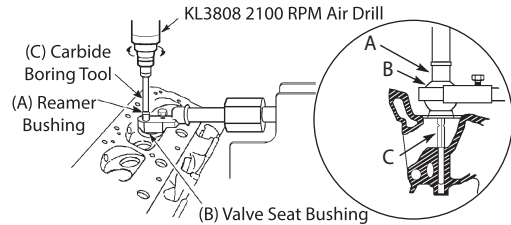

STEP 2 INSTALL

- Blow away chips.
- Insert Bronze Bullet® (pages 4-7) into holder assembly of the Bronze Bullet® Auto-Installer (page 11).
- Drive into place with a short stroke H.D. Air Hammer.
- If the Guide-Liner® installs hard and is under a lot of stress; it is recommended that K-Line® Bronze Lube KL1225 (page 11) be applied providing that the Guide-Liner® doesn't move while ball broaching. If the Guide-Liner® installs easily, it is recommended that no Bronze lube be used. In most cases and in the beginning practice, no Bronze lube should be used.

NOTE: On powdered metal guides you may need to run a Flex-Hone® (page 14) prior to installation.

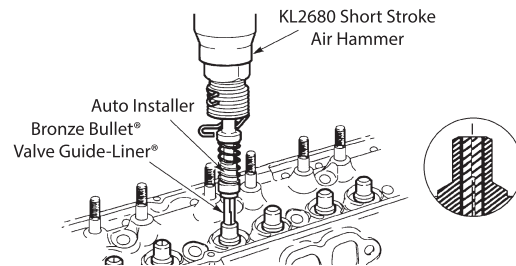

STEP 3 SIZE

- Use Bronze Lube (page 11) in guide and on tool prior to sizing.
- Insert K-Line® Ball Broach (page 12) in guide and drive by air with a Broach Holder KL5758 or KL5759 (page 12) and Air Hammer KL2680 (page 14).

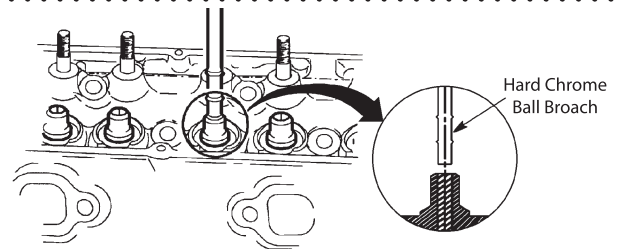

STEP 4 TRIM

Insert appropriate size pilot into K-Line® Carbide Guide Top Cutter (page 13). Using a 2,100 RPM drill KL3808 (page 10), remove any excess Guide-Liner® material from each side of the valve guide.

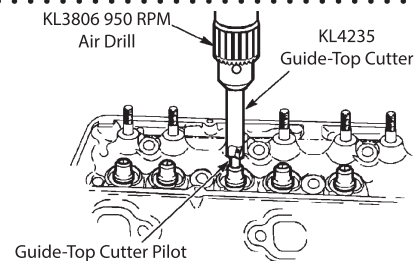

STEP 5 FLEX-HONE (OPTIONAL)

Run the appropriate size Flex-Hone® (page 14) through the Guide-Liner® with a 2,100 RPM drill KL3808 (page 10). One pass down and one pass up will provide the desired finish.

NOTE: After flex honing, proper guide cleaning is required.

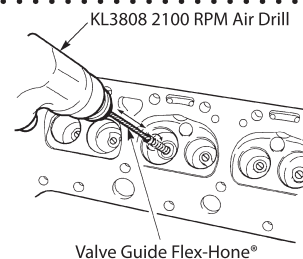

BRONZE BULLET® INTERRUPTED SPIRAL® VALVE GUIDE-LINERS®

Choosing the Right Guide-Liner

Select the proper guide I.D. which corresponds to the clearances you desire. All Guide-Liners have been designed for maximum performance when finished to the stated minimum finished guide I.D. or larger.

Choosing the Right Sizing Tool

To obtain the recommended finished guide I.D., select a slightly larger ball broach (due to material flow-back that occurs during this sizing operation) typically, .001 to .0015 larger than the desired finished I.D.

FRACTIONAL SIZES

	Min. Fin. ID	Length	Part No.	Min. Fin. ID	Length	Part No.
5/16"	.310 (7.87)	3.13 (79.5)	KL1927STA	.313 (7.95)	3.13 (79.5)	KL1840STA
	.3425 (8.70) BORED HOLE MAXIMUM ID					
11/32"	.339 (8.61)	2.50 (63.5)	KL1961STA	.343 (8.71)	3.13 (79.5)	KL1841STA
	.341 (8.66)	2.50 (63.5)	KL1983STA	.344 (8.74)	2.50 (63.5)	KL1921STA
	.342 (8.69)	2.50 (63.5)	KL1932STA			
	.3735 (9.49) BORED HOLE MAXIMUM ID					
3/8"	.370 (9.40)	3.13 (79.5)	KL1902STA	.374 (9.50)	3.13 (79.5)	KL1842STA
	.373 (9.47)	3.13 (79.5)	KL1992STA	.375 (9.53)	2.50 (63.5)	KL1975STA
	.374 (9.50)	2.50 (63.5)	KL1974STA			
	.4055 (10.30) BORED HOLE MAXIMUM ID					

*Highlighted part # designates universal length.

MILLIMETER SIZES

	Min. Fin. ID	Length	Part No.	Min. Fin. ID	Length	Part No.
5mm	.197 (5.00)	1.63 (41.3)	KL1858STA			
.2125 (5.40) BORED HOLE MAXIMUM ID						
5.5mm	.216 (5.49)	2.25 (57.2)	KL1857STA	.217 (5.51)	2.50 (63.5)	KL1900STA
.2485 (6.31) BORED HOLE MAXIMUM ID						
6mm	.238 (6.05)	2.25 (57.2)	KL1906STA	.236 (6.00)	2.25 (57.2)	KL1856STA
.2675 (6.79) BORED HOLE MAXIMUM ID						
6.6mm	.260 (6.60)	2.50 (63.5)	KL1849STA			
.2915 (7.40) BORED HOLE MAXIMUM ID						
7mm	.273 (6.93)	2.50 (63.5)	KL1904STA	.277 (7.03)	2.50 (63.5)	KL1850STA
	.275 (6.98)	3.00 (76.2)	KL19100STA	.278 (7.06)	1.81 (46.0)	KL1903STA
	.276 (7.01)	2.75 (69.9)	KL19107STA	.279 (7.09)	2.50 (63.5)	KL1909STA
	.3095 (7.86) BORED HOLE MAXIMUM ID					
8mm	.312 (7.92)	2.50 (63.5)	KL1944STA	.316 (8.03)	2.50 (63.5)	KL1851STA
	.313 (7.95)	2.50 (63.5)	KL1933STA	.317 (8.05)	2.50 (63.5)	KL1940STA
	.313 (7.95)	3.00 (76.2)	KL1937STA	.317 (8.05)	3.13 (79.5)	KL19101STA
	.314 (7.98)	2.50 (63.5)	KL1997STA	.318 (8.08)	2.50 (63.5)	KL1942STA
	.315 (8.00)	2.50 (63.5)	KL1939STA	.318 (8.08)	2.75 (69.9)	KL1967STA
	.315 (8.00)	3.15 (80.0)	KL1968STA			
.3475 (8.83) BORED HOLE MAXIMUM ID						

Min. Fin. ID	Length	Part No.	Min. Fin. ID	Length	Part No.		
.346 (8.79)	2.50 (63.5)	KL19103STA	.354 (8.99)	3.13 (79.5)	KL1925STA	9mm	
.....							
.3865 (9.82)	BORED HOLE MAXIMUM ID						
.393 (9.98)	3.13 (79.5)	KL1920STA				10mm	
.....							
.4255 (10.81)	BORED HOLE MAXIMUM ID						
.432 (10.97)	2.50 (63.5)	KL1988STA	.433 (11.00)	3.25 (82.6)	KL1905STA	11mm	
.....							
.4675 (11.87)	BORED HOLE MAXIMUM ID						

* Highlighted part # designates universal length.

BRONZE BULLET® SMOOTH WALL VALVE GUIDE-LINERS®

FRACTIONAL SIZES

Min. Fin. ID	Length	Part No.	
.312 (7.92)	3.13 (79.5)	KL1840A	5/16"
.....			
.3425 (8.70)	BORED HOLE MAXIMUM ID		
.343 (8.71)	3.13 (61.0)	KL1841A	11/32"
.....			
.3735 (9.49)	BORED HOLE MAXIMUM ID		
.374 (9.50)	3.13 (79.5)	KL1842A	3/8"
.....			
.4055 (10.30)	BORED HOLE MAXIMUM ID		

MILLIMETER SIZES

Min. Fin. ID	Length	Part No.	
.277 (7.03)	2.50 (63.5)	KL1850A	7mm
.....			
.3095 (7.86)	BORED HOLE MAXIMUM ID		

* Highlighted part # designates universal length.

0.36 OVERSIZE THIN-WALL

Min. Fin. ID	Length	Qty.	Part No.
.343 (8.71)	3.13 (79.5)	100	KL1860A
.....			
.375 (9.53)	BORED HOLE MAXIMUM ID		

Min. Fin. ID	Length	Qty.	Part No.
.374 (9.53)	3.13 (79.5)	100	KL1861A
.....			
.406 (10.31)	BORED HOLE MAXIMUM ID		

0.60 HEAVY DUTY THICK-WALL

Min. Fin. ID	Length	Qty.	Part No.	
.343 (8.71)	3.25 (82.6)	100	KL1845A	11/32"
.....				
.4055 (10.30)	BORED HOLE MAXIMUM ID			

3/8"

BORED HOLE TOLERANCES

FRACTIONAL

5/16"	.341 (8.66)	-	.3425 (8.700)
11/32"	.372 (9.45)	-	.3735 (9.487)
3/8"	.404 (10.26)	-	.4055 (10.30)

MILLIMETER

5mm	.212 (5.37)	-	.2125 (5.395)
5.5mm	.247 (6.27)	-	.2485 (6.312)
6mm	.266 (6.76)	-	.2675 (6.795)
6.6mm	.290 (7.37)	-	.2915 (7.404)
7mm	.308 (7.82)	-	.3095 (7.861)
8mm	.346 (8.79)	-	.3475 (8.827)
8.5mm	.367 (9.32)	-	.3685 (9.360)
9mm	.385 (9.78)	-	.3865 (9.817)
10mm	.424 (10.77)	-	.4255 (10.81)
11mm	.466 (11.84)	-	.4675 (11.87)

Other U.S. and Foreign Patents Pending.

K-Line®, Bronze Bullet®, Interrupted Spiral®, Guide-Liner®, and Bron-EL® are registered trademarks of K-Line® Industries, Inc.



BRONZE BULLET® GUIDE-LINER® KITS



RX STANDARD GUIDE-LINER® AIR INSTALLATION KITS

These tool kits are designed for the smaller to mid-sized shop, answering the need for a more economical tooling kit package. Each kit features a Carbide Boring Reamer with accessories, packaged in a plastic storage box with step-by-step instructions.

These kits are designed to be used with KL9907 or KL9910 Seat Bushing Kits.

NOTE: Please refer to the RPM chart of Pages 18-19 for recommended RPM ranges by reamer type and diameter.

Guide Size Kit No.	Step 1				Step 2				Step 3				Step 4
	Boring Reamer	Reamer Bushing	Guide Brush	Auto Installer	Ball Broaches				Trim Tool				
5/16" KL1600RX	KL1719C-9	KL9932	KL1036	KL9961	KL5844/.312	KL5845/.313	KL5846/.314		KL1787				
11/32" KL1601RX	KL1725C-9	KL9934	KL1036	KL9962	KL5857/.3435	KL5858/.3445	KL5859/.3455		KL1797				
3/8" KL1602RX	KL1735C-9	KL9936	KL1036	KL9963	KL5872/.374	KL5873/.375	KL5874/.376		KL1807				
5 mm KL1613RX	KL3556CC	KL9921	KL1036	KL9957	KL5901/.1973	KL5902/.1978	KL5903/.1983		KL4230 KL4247				
5.5mm KL1614RX	*KL3561CC	KL9922	KL1036	KL9958	KL5808/.217	KL5809/.2175	KL5810/.218	KL5811/.2185	KL3184				
6mm KL1612RX	KL3566C-9	KL9929	KL1036	KL9971	KL5815/.237	KL5816/.2375	KL5817/.238	KL5818/.2385	KL3185				
6.6mm KL1606RX	KL3571C-9	KL9930	KL1036	KL9972	KL5825/.260	KL5826/.261	KL5827/.262		KL3205				
7mm KL1607RX	KL3576C-9	KL9931	KL1036	KL9973	KL5835/.276	KL5836/.277	KL5837/.278	KL5838/.279	KL1897				
8mm KL1608RX	KL3581C-9	KL9933	KL1036	KL9968	KL5847/.315	KL5848/.316	KL5849/.317		KL1787				
9mm KL1609RX	KL3586C-9	KL9935	KL1036	KL9969	KL5864/.354	KL5865/.355	KL5866/.356		KL3235				

* Guide Pro® Solid Carbide Boring Reamer.

VALVE SEAT BUSHING KITS

These kits offers sizes to fit most valve seats. Bushings easily disconnect from fixture head for quick size changes. Kits come in a sturdy, padded plastic storage case.



KL9910 (9 Pc. Kit)

Part No.	
KL9911 1"
KL9912 1-3/16"
KL9913 1-3/8"
KL9914 1-1/2"
KL9915 1-5/8"
KL9916 1-3/4"
KL9917 1-7/8"
KL9918 2"
KL9919 2-1/4"

KL9907 (7 Pc. Kit)

Part No.	
KL9911 1"
KL9912 1-3/16"
KL9913 1-3/8"
KL9915 1-5/8"
KL9916 1-3/4"
KL9918 2"
KL9919 2-1/4"

KL9920 2-1/2" (sold separately)

These kits are designed to be used with the RX or NX Guide-Liner® Air Installation Kits

BRONZE BULLET® GUIDE-LINER® KITS



NX DELUXE GUIDE-LINER® AIR INSTALLATION KITS

Complete kit designed for use with KL9900, featuring the Black Beauty® Carbide Boring Reamer and deluxe tooling. Packaged in a plastic storage box, complete with step-by-step instructions.



These kits are designed to be used with KL9907 or KL9910 Seat Bushing Kits.

Step 1		Step 2		Step 3	Step 4	Step 5			Guide Size Kit No.	
Boring Reamer	Reamer Bushing	Go-No-Go Gage	Guide Brush	Auto Installer	Ball Broaches	Guide-Top Cutter	Cutter Pilot	Flex Hone	Removal Tool	
KL1719CB-9	KL9932	KL2500	KL1036	KL9961	KL5844/.312 KL5845/.313 KL5846/.314	KL4235	KL4238	KL2427	KL5680	5/16" KL1600NX
KL1725CB-9	KL9934	KL2501	KL1036	KL9962	KL5857/.3435 KL5858/.3445 KL5859/.3455	KL4235	KL4239	KL2428	KL5681	11/32" KL1601NX
KL1735CB-9	KL9936	KL2502	KL1036	KL9963	KL5872/.374 KL5873/.375 KL5874/.376	KL4235	KL4240	KL2419	KL5682	3/8" KL1602NX
*KL3556CC	KL9921	KL2514	KL1036	KL9957	KL5901/.1973 KL5902/.1978 KL5903/.1983	KL4230	KL4247	KL2422	KL5677	5mm KL1613NX
*KL3561CC	KL9922	KL2498	KL1036	KL9958	KL5808/.217 KL5809/.2175 KL5810/.218 KL5811/.2185	KL4233	KL4246	KL2424	KL5678	5.5mm KL1614NX
KL3566CB-9	KL9929	KL2499	KL1036	KL9971	KL5815/.237 KL5816/.2375 KL5817/.238 KL5818/.2385	KL4233	KL4245	KL2423	KL5679	6mm KL1612NX
KL3571CB-9	KL9930	KL2504	KL1036	KL9972	KL5825/.260 KL5826/.261 KL5827/.262	KL4233	KL4242	KL2425	KL5684	6.6mm KL1606NX
KL3576CB-9	KL9931	KL2505	KL1036	KL9973	KL5835/.276 KL5836/.277 KL5837/.278 KL5838/.279	KL4233	KL4243	KL2426	KL5685	7mm KL1607NX
KL3581CB-9	KL9933	KL2506	KL1036	KL9968	KL5847/.315 KL5848/.316 KL5849/.317	KL4235	KL4238	KL2427	KL5686	8mm KL1608NX
KL3586CB-9	KL9935	KL2507	KL1036	KL9969	KL5864/.354 KL5865/.355 KL5866/.356	KL4235	KL4244	KL2428	KL5687	9mm KL1609NX
KL3591CB-9	KL9939	KL2508	KL1036	KL9970	KL5876/.394 KL5877/.395 KL5878/.396	KL4235	KL4248	KL2429	KL5688	10mm KL1610NX
KL1749CB-9	KL9937	KL2503	KL1036	KL9964	KL5880/.433 KL5881/.434 KL5882/.435	KL4235	KL4241	KL2430	KL5689	11mm KL1611NX

* Guide Pro® Solid Carbide Boring Reamer.

Steps 1, 4 & 5 use KL3808 Drill - 2100 RPM. Steps 2 & 3 use KL2680 Air Hammer - 4,500 blows/min.

Step 3 recommended purchase (KL5758, KL5759) Ball Broach Driver.

STEP 1

BORE



KL9900 VALVE GUIDE BORING FIXTURE

The K-Line® Valve Guide Boring Fixture has been uniquely designed to meet the needs of the quality minded engine rebuilder. This boring fixture provides perfect alignment with the valve seat for boring out worn valve guides prior to K-Line® Guide-Liner® Installation.

Used in conjunction with K-Line® boring tools, including the Black Beauty® Guide Pro® Solid Carbide Boring Reamers, you can expect unmatched consistency, speed and performance. Two-point alignment and positive clamping action ensures that guide-to-seat alignment is precise. Finished in a durable hammertone blue powder coating.

Made in U.S.A. U.S. Patent No. 5,281,057.
Canadian Patent No. 2,090,627.
Other U.S. & foreign patents pending.
Dimensions: 35"W x 24"D x 22"H
F.O.B. Holland, MI

KL9900 Boring Fixture

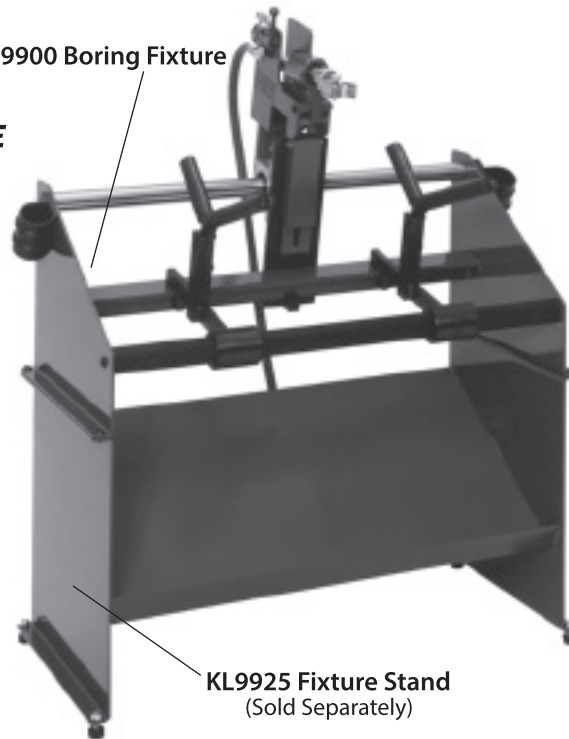

KL9925 Fixture Stand
(Sold Separately)

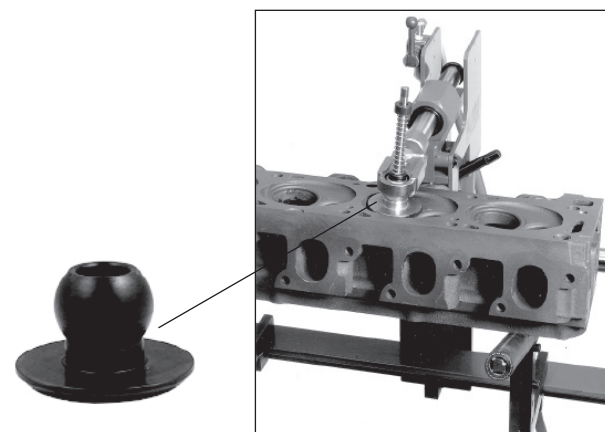

Features

- Accommodates all popular heads, cast iron and aluminum, including multi-valve dual overhead cam designs.
- Adjustable V-cradle head stands (height & width) are non-tip for safe operation.
- Twin bearings in boring fixture head for longer life.
- Boring fixture head and stands are slightly angled to reduce operator fatigue.
- Air control valve is centrally located for quick on/off clamping action.
- Quick disconnect for interchangeable valve seat bushings.
- Built-in air tool holsters for easy air tool accessibility.

A must for high-performance applications, heads with canted or opposing guides and production environments.

KL9925 FIXTURE STAND

Custom designed to fit the KL9900 Boring Fixture. Enhances the ergonomics of the KL9900. Angled back splash catches metal chips.

Dimensions: 35"W x 24"D x 22"H
F.O.B. Holland, MI

KL9900 REPLACEMENT PARTS

KL9900-29A Air Valve w/Lever

KL9900-25 Spring Plunger

STEP 1 BORE



BLACK BEAUTY® CARBIDE BORING TOOLS FOR CAST IRON GUIDES

The Ultimate Boring Tool for Precision and Extra Long Life

- Hardness - Rockwell C hardness of 93-95 allows faster operating speeds with extended tool life - even in hardened guides.
- Unique molecular structure resists galling or chip build up, resulting in reduced tool temperature.
- Lubricity - The lubricious surface aids in maintaining a lower temperature and efficient chip removal.
- Low temperature application process eliminates the possibility of tool warpage or annealing.
- Precision - Each reamer is carefully crafted to a .0002 tolerance or less. Hole sizing is true and consistent.

Replacement Boring Tools for NX Series Guide-Liner® Kits

Part No.	Size	Use With
KL1719CB-9	.312 - .030	5/16" Guide-Liners®
KL1725CB-9	.343 - .030	11/32" Guide-Liners®
KL1735CB-9	.375 - .030	3/8" Guide-Liners®
KL3566CB-9	.236 - .030	6.0mm Guide-Liners®
KL3571CB-9	.260 - .030	6.6mm Guide-Liners®
KL3576CB-9	.275 - .030	7mm Guide-Liners®
KL3581CB-9	.315 - .030	8mm Guide-Liners®
KL3586CB-9	.354 - .030	9mm Guide-Liners®
KL3591CB-9	.394 - .030	10mm Guide-Liners®
KL1749CB-9	.437 - .030	11mm Guide-Liners®

Black Beauty® is a registered trademark of K-Line® Industries, Inc. 9" Overall Length

STANDARD CARBIDE BORING TOOLS FOR CAST IRON GUIDES

Replacement Boring Tools for RX Series Guide-Liner® Kits



Part No.	Size	Use With
KL1719C-9	.312 - .030	5/16" Guide-Liners®
KL1725C-9	.343 - .030	11/32" Guide-Liners®
KL1735C-9	.375 - .030	3/8" Guide-Liners®
KL3566C-9	.236 - .030	6mm Guide-Liners®
KL3571C-9	.260 - .030	6.6mm Guide-Liners®
KL3576C-9	.275 - .030	7mm Guide-Liners®
KL3581C-9	.315 - .030	8mm Guide-Liners®
KL3586C-9	.354 - .030	9mm Guide-Liners®

9" Overall Length

BLACK BEAUTY® CARBIDE BORING TOOLS FOR BRONZE GUIDES

Specifically designed to bore Manganese Bronze, Aluminum Bronze and Silicon Aluminum Bronze prior to Guide-Liner® installation.

Part No.	Size
KL3519CSP	5/16" - 30
KL3525CSP	11/32" - 30
KL3535CSP	3/8" - 30
KL3561CSP	5.5mm - 30
KL3566CSP	6mm - 30
KL3571CSP	6.6mm - 30
KL3576CSP	7mm - 30
KL3581CSP	8mm - 30

9" Overall Length

REAMER BUSHINGS

Replacement Reamer Bushings for NX/RX Series Guide-Liner® Kits



Part No.	Size
KL9932	5/16"
KL9934	11/32"
KL9936	3/8"

Part No.	Size
KL9921	5mm
KL9922	5.5mm
KL9929	6mm
KL9930	6.6mm

Part No.	Size
KL9931	7mm
KL9933	8mm
KL9935	9mm
KL9939	10mm
KL9937	11mm

STEP 1 BORE

GUIDE PRO® SOLID CARBIDE BLACK BEAUTY® BORING TOOLS

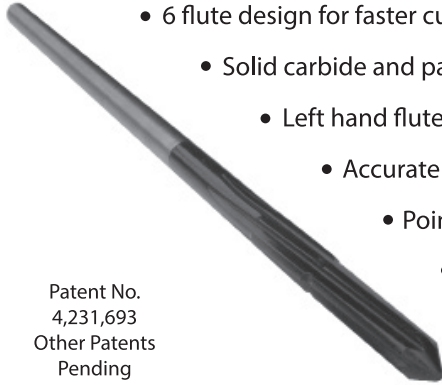

- 6 flute design for faster cutting action
- Solid carbide and patented Black Beauty® process provide increased longevity
- Left hand flutes send chips down out of the way for size consistency
- Accurately bores in most types of valve guide materials
- Pointed pilot for faster hole location
- Patented tool design provides a smoother finish

Patent No.
4,231,693
Other Patents
Pending

An exclusive line of Guide-Liner® boring tools designed to cut faster, straighter holes. Coupled with our patented Black Beauty® process and patented cutting geometric design, these solid carbide reamers provide a smoother finish. Life expectancy is considerably greater than standard brazed carbide boring tools.

Part No.	Size	Use With
KL3556CC	.197 - .030	5mm
KL3561CC	.216 - .030	5.5mm
KL3566CC	.236 - .030	6mm
KL3576CC	.275 - .030	7mm
KL3581CC	.315 - .030	8mm
KL3586CC	.354 - .030	9mm

Part No.	Size	Use With
KL1719CC	.312 - .030	5/16"
KL1725CC	.343 - .030	11/32"
KL1735CC	.375 - .030	3/8"

Go-No-Go GAUGES

Designed to be used as a quick check after boring the original valve guide. Will detect under or over sizing of the valve guide before installation of the Guide-Liner®. Will also help the machinist know when the boring tool is approaching dull stage and needs to be sharpened or replaced.

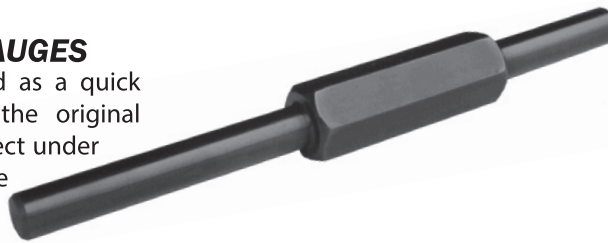

Part No.	Size
KL2500	5/16"
KL2501	11/32"
KL2502	3/8"

Part No.	Size
KL2514	5mm
KL2498	5.5mm
KL2499	6mm
KL2504	6.6mm
KL2505	7mm
KL2506	8mm
KL2507	9mm
KL2508	10mm
KL2503	11mm

STEP 2 INSTALL



BRONZE BULLET® AUTO INSTALLER **#1 Rated Installation Tool**

This universal tool features a Guide-Liner® holder incorporated into the driver assembly, making installation quick and effortless. Attach the Auto-Installer to the KL2680 H.D. Air Hammer, insert the Bronze Bullet® liner into the holder assembly, position the driver pilot and Bronze Bullet® liner into the bored hole and drive the Bronze Bullet® liner into the hole until the driver shoulder reaches the guide boss. The Auto-Installer eliminates the need for a separate holder and driver and can cut installation time in half.

U.S. Patent No. 5,355,572

Part No.	Size
KL9961	5/16"
KL9962	11/32"
KL9963	3/8"
KL9968	8mm
KL9969	9mm
KL9970	10mm
KL9964	11mm

SMALL DIAMETER BRONZE BULLET® AUTO INSTALLER

This line of metric auto installers features a reduced diameter Guide-Liner® holder for improved access to the valve guide in modern aluminum cylinder heads with small diameter valve bowls or overhead cam towers.

U.S. Patent No. 5,355,572

Part No.	Size
KL9957	5mm
KL9958	5.5mm
KL9971	6mm
KL9972	6.6mm
KL9973	7mm



BRONZE LUBE **For Knurling and Reaming**

This oil is specially formulated for guide knurling and finish reaming. Reamer and arbor life will be extended if the proper amount and type of oil is used. Bronze Lube should be used on bronze Guide-Liners®, but can also be used on cast iron guides.

KL1224 Pint
KL1225 Quart



STEP 3 SIZE



HARD CHROME PLATED BALL BROACHES

A simple, fast method for sizing the inside diameter of Bronze Guide-Liners®. Made of high quality tool steel, hard chrome plated, with a special ground double ball configuration that quickly sizes the inside diameter and eliminates reaming or honing. Use with KL5758 or KL5759 Broach Holder/Driver shown below with KL2680 Air Hammer (page 15). U.S. Patent No. 4,573,346. Canadian Patent No. 1,219,742.

	Part No.	Ball Size
5/16"	KL5842	.310 (7.87)
	KL5843	.311 (7.90)
	KL5844	.312 (7.92)
	KL5845	.313 (7.95)
	KL5846	.314 (7.98)
	KL5855	.341 (8.66)
11/32"	KL5856	.342 (8.69)
	KL5857	.3435 (8.725)
	KL5858	.3445 (8.750)
	KL5889	.345 (8.76)
	KL5859	.3455 (8.776)
	KL5860	.3465 (8.801)
3/8"	KL5871	.372 (9.45)
	KL5869	.373 (9.47)
	KL5872	.374 (9.50)
	KL5892	.3745 (9.512)
	KL5873	.375 (9.53)
	KL5893	.3755 (9.538)
	KL5874	.376 (9.55)
	KL5890	.377 (9.58)

	Part No.	Ball Size
5mm	KL5901	.1973 (5.011)
	KL5902	.1978 (5.024)
	KL5903	.1983 (5.037)
5.5mm	KL5808	.217 (5.51)
	KL5809	.2175 (5.525)
	KL5810	.218 (5.54)
	KL5811	.2185 (5.550)
6mm	KL5813	.235 (5.97)
	KL5814	.236 (6.00)
	KL5815	.237 (6.02)
	KL5816	.2375 (6.033)
	KL5817	.238 (6.05)
	KL5818	.2385 (6.058)
6.6mm	KL5819	.239 (6.07)
	KL5820	.2395 (6.083)
	KL5825	.260 (6.60)
	KL5826	.261 (6.63)
	KL5827	.262 (6.65)

	Part No.	Ball Size
7mm	KL5834	.275 (6.99)
	KL5835	.276 (7.01)
	KL5836	.277 (7.04)
	KL5837	.278 (7.06)
	KL5838	.279 (7.09)
	KL5839	.280 (7.11)
	KL5840	.281 (7.14)
	KL5847	.315 (8.00)
	KL5848	.316 (8.03)
	KL5849	.317 (8.05)
8mm	KL5850	.318 (8.08)
	KL5851	.319 (8.10)
	KL5852	.320 (8.13)
	KL5864	.354 (8.99)
	KL5865	.355 (9.02)
	KL5866	.356 (9.04)
9mm	KL5876	.394 (10.00)
	KL5877	.395 (10.03)
10mm	KL5878	.396 (10.06)
	KL5880	.433 (11.00)
11mm	KL5881	.434 (11.02)
	KL5882	.435 (11.05)

IMPORTANT: to obtain the recommended finished guide I.D., a slightly larger ball broach will be required (due to material flow-back that occurs during this sizing operation) typically, .001" (.025mm) to .0015" (.038mm) larger than the desired finished I.D.

AIR HAMMER BALL BROACH HOLDER/DRIVER



Part No.	Description
KL5758	For Ball Broaches 5mm - 8mm
KL5759	For Ball Broaches 11/32" - 11mm
KL5759B	Replacement Bumper

STEP 4 TRIM

KL4235 GUIDE-TOP CUTTER

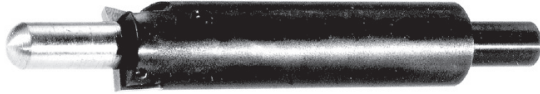

Designed to be used when cutting excess Guide-Liners®. It has replaceable carbide blades, which are fastened on with screws. Uses standard K-Line® guide-top cutter pilots.

KL4236 Replacement Carbide Blade (2 required)

KL4237 Replacement Holding Screw

Cutter Pilots

Part No.	Cutters
KL4238	5/16" - 8mm
KL4239	11/32"
KL4240	3/8"
KL4244	9mm
KL4248	10mm
KL4241	11mm

The tool shank is 5/8" in diameter x 4" long and the reversible carbide blade is .720 in diameter.

KL4230 5MM DELUXE GUIDE-TOP CUTTER

Reversible Carbide Blade

This deluxe cutter is ideal for cutting excess Guide-Liner® material from valve guide bosses in limited clearance areas found on small port cylinder heads. The tool shank is 3/8" in diameter x 3¾" long and the reversible carbide blade can cut up to a 7/16" diameter guide boss. For use with the KL4246 5mm Cutter Pilot.

KL4247 Cutter Pilot

KL4230A Replacement Carbide Blade

KL4233 SMALL DIAMETER DELUXE GUIDE-TOP CUTTER



Reversible Carbide Blade

This deluxe cutter is ideal for cutting excess Guide-Liner® material from valve guide bosses in limited clearance areas found on small port cylinder heads. Pilots are interchangeable with the larger KL4235A Deluxe Guide-Top Cutter.

Cutter Pilots

Part No.	Cutters
KL4246	5.5mm
KL4245	6mm
KL4242	6.6mm
KL4243	7mm

The tool shank is 3/8" in diameter x 3¾" long and the reversible carbide blade can cut up to a 7/16" diameter guide boss.

KL4234 Replacement Carbide Blade

GUIDE-LINER® TRIMMING TOOL

For manually trimming off excess Guide-Liner® material after installation.

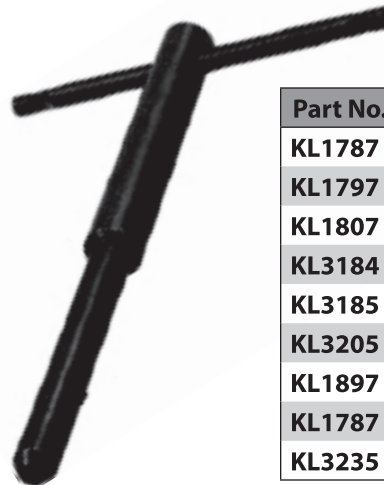

Part No.	Size
KL1787	5/16"
KL1797	11/32"
KL1807	3/8"
KL3184	5.5mm
KL3185	6mm
KL3205	6.6mm
KL1897	7mm
KL1787	8mm
KL3235	9mm

STEP 5 (OPTIONAL) FLEX-HONE®

VALVE GUIDE FLEX-HONES®

Ideal for Precision, Final Fitting of Valves to Guide-Liners®

Use with power drill or guide and seat machine. Simply run the closest size FLEX-HONE® through the guide. Works with all guide materials: cast iron, bronze, Bron-EL® and silicon aluminum-bronze. Recommended for one pass final finish on Bronze Guide-Liners.

NOTE: After flex honing, proper guide cleaning is required.

Recommended for use with KL3808 2100 RPM Air Drill to activate approximately 20-23 Ra in Bronze Guide-Liners®.



Part No.	Size	Grit
KL2422	5mm	240
KL2424	5.5mm	240
KL2423	6mm	240
KL2425	6.6mm	240
KL2426	7mm	240
KL2427	5/16" (8mm)	240
KL2428	11/32" (9mm)	240
KL2419	3/8"	240
KL2429	10mm	240
KL2430	11mm	240

GUIDE-LINER® REMOVAL TOOL

#1 Rated Removal Tool



Easily removes old Guide-Liners® without disrupting original guide bore. Pilot aligns tool as you drive it through the guide. Air Hammer Ball Broach Holder/Driver required with removal tool when using pneumatic hammer to remove the Guide-Liner®

Part No.	Guide-Liner® Size
KL5680	5/16"
KL5681	11/32"
KL5682	3/8"
KL5677	5mm
KL5678	5.5mm
KL5679	6mm
KL5684	6.6mm
KL5685	7mm
KL5686	8mm
KL5687	9mm
KL5688	10mm
KL5689	11mm

STEEL-GRIP® VALVE SEALS Positive Oil Control

For positive oil control, nothing does the job better than this seal. A special Teflon® sealing element assures positive oil control, but will not “dry up” valve stems. The special steel housing will not crack or vibrate loose. The outside diameter of the housing is extremely narrow so it will have ample clearance on double valve spring setups. This seal has solved many problems connected with oil loss through the valve stems. Can also be used on thin-wall replacement guides, both cast iron and the Bronze Guide-Liners®.



- Can be installed with your present valve guide machining tools for boot type seals.
- Specially formulated graphite impregnated Teflon® sealing element.
- Self-tightening seal design assures longer life.
- Steel housing will not vibrate loose, crack or disintegrate.

U.S. Patent No:s 4,502,696; 4,822,061. Canadian Patent No. 890792

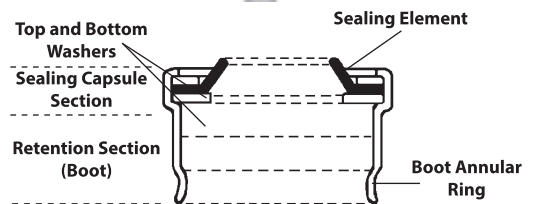

VALVE SEALS

Part No.	Stem x Guide
122-1224	1/4" x .385
322-1019	5/16" x .530
322-1020	11/32" x .500
322-1021	11/32" x .530
322-1022	3/8" x .530
322-1023	3/8" x .562
•122-1223	5/16" x .420
••122-1399	5/16" x .420
•122-1221	11/32" x .562
••122-1400	3/8" x .625

- Designed for Detroit Diesel
- Designed for Harley-Davidson

SEAL DRIVERS

Part No.	For Seal No.
122-9003	322-1018, 322-1020, 322-1019, 322-1021, 322-1022, 122-1400
122-9005	122-1399
122-9004	322-1023, 122-1223, 122-1221

PROTECTOR SLEEVES

Part No.	For Seal No.
122-9000	122-1399, 322-1018, 322-1019, 122-1223
122-9001	322-1020, 322-1021, 122-1221
122-9002	322-1022, 322-1023, 122-1400

BRONZE VALVE GUIDE FINISH REAMERS

- Whether you are reaming Manganese Bronze, Aluminum Bronze or Silicon Aluminum Bronze, you can count on cutting more holes per reamer.
- Specially fluted, heat-treated and ground to give you improved cutting geometry.
- A new pointed pilot allows for easier insertion into guide and better chip removal
- You can count on getting longer life and greater consistency from hole to hole.
- K-Line's Bronze Valve Guide Finish Reamers produce a smooth on-size I.D. while they resist galling.

Patent Numbers 4,231,693 and 5,921,728

*“K-Line Bronze Guide Reamers:
quick, accurate, long-lasting.”*

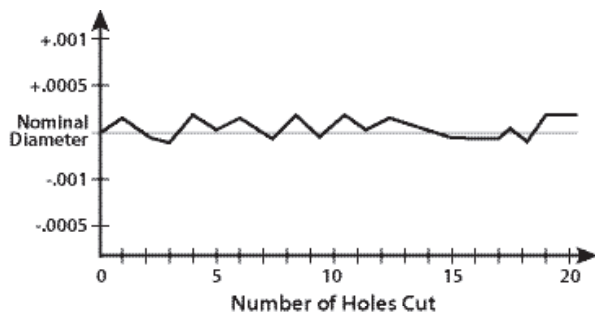

Part No.	Size
KL1185NB	.2165 (5.5mm)
KL1110NB	.236 (6mm)
KL1173NB	.260 (6.6mm)
KL1111NB	.2755 (7mm)
KL1116NB	.310 (7.87)
KL1117NB	.311 (7.90)
KL1118NB	.312 (5/16")
KL1176NB	.313 (7.95)
KL1177NB	.314 (7.98)
KL1112NB	.315 (8mm)
KL1174NB	.316 (8.03)
KL1175NB	.317 (8.05)
KL1119NB	.341 (8.66)
KL1120NB	.342 (8.69)
KL1121NB	.343 (8.71)
KL1122NB	.344 (11/32")
KL1123NB	.345 (8.76)
KL1113NB	.3543 (9mm)
KL1124NB	.371 (9.42)
KL1125NB	.372 (9.45)
KL1126NB	.373 (9.47)
KL1127NB	.374 (9.50)
KL1128NB	.375 (3/8")
KL1193NB	.377 (9.58)
KL1182NB	.378 (9.60)

All sizes listed are in stock for immediate delivery. **Special reamer sizes also available.** Specials must be within .003 smaller than standard listed reamer. Charge for these is determined from the cost of larger standard size. **Additional grinding charge is added for H.S. Steel and Bronze Reamers.**

H.S.S. FINISH REAMERS FOR CAST IRON VALVE GUIDES



High quality reamers crafted from the finest tools steel and tempered for long life. Reamers are piloted for self-centering action. Spiral flutes give a smooth, even cut. A new pointed pilot allows for easier insertion into guide and better chip removal. With proper care, they will accurately size thousands of guides.

All sizes listed are in stock for immediate delivery. **Special reamer sizes also available.** Specials must be within .003 smaller than standard listed reamer. Charge for these is determined from the cost of larger standard size. **Additional grinding charge is added for H.S. Steel and Bronze Reamers.**

Part No.	Size
KL1060	.197 (5.00)
KL1061	.214 (5.44)
KL1062	.215 (5.46)
KL1185	.2165 (5.50)
KL1063	.217 (5.51)
KL1064	.218 (5.54)
KL1199	.234 (5.94)
KL1216	.235 (5.97)
KL1110	.2362 (6.00)
KL1217	.237 (6.02)
KL1115	.250 (1/4")
KL1207	.258 (6.55)
KL1208	.259 (6.58)
KL1173	.260 (6.60)
KL1157	.274 (6.96)
KL1111	.2756 (7.00)
KL1214	.276 (7.01)
KL1148	.277 (7.03)
KL1187	.281 (9/32")
KL1117	.311 (7.90)
KL1118	.312 (5/16")
KL1176	.313 (7.95)

Part No.	Size
KL1177	.314 (7.97)
KL1112	.315 (8.00)
KL1174	.316 (8.03)
KL1175	.317 (8.05)
KL1178	.318 (8.08)
KL1188	.327 (8.31)
KL1203	.330 (8.38)
KL1119	.341 (8.66)
KL1120	.342 (8.69)
KL1121	.343 (8.71)
KL1180	.3435 (11/32")
KL1122	.344 (8.74)
KL1123	.345 (8.76)
KL1136	.346 (8.79)
KL1181	.347 (8.81)
KL1190	.353 (8.97)
KL1113	.3542 (9.00)

Part No.	Size
KL1191	.355 (9.02)
KL1192	.356 (9.04)
KL1215	.357 (9.06)
KL1138	.358 (9.09)
KL1125	.372 (9.45)
KL1126	.373 (9.47)
KL1127	.374 (9.50)
KL1128	.375 (3/8")
KL1139	.376 (9.55)
KL1193	.377 (9.58)
KL1182	.378 (9.60)
KL1209	.379 (9.63)
KL1194	.380 (9.65)
KL1213	.381 (9.68)
KL1196	.388 (9.86)
KL1197	.390 (25/64")
KL1205	.393 (9.98)
KL1114	.3937 (10.00)

K-LINE® REAMER RPM BY TYPE AND SIZE

K-LINE REAMER #	NOMINAL	SIZE	RPM RANGE
BLACK BEAUTY® CARBIDE BORING REAMERS FOR CAST IRON GUIDES			
KL1719CB-9	5/16"	.312 - .030	1,600-2,000
KL1725CB-9	11/32"	.343 - .030	1,400-1,800
KL1735CB-9	3/8"	.375 - .030	1,300-1,700
KL3566CB-9	6.00mm	.236 - .030	2,300-2,700
KL3571CB-9	6.60mm	.260 - .030	2,000-2,400
KL3576CB-9	7.00mm	.275 - .030	1,900-2,300
KL3581CB-9	8.00mm	.315 - .030	1,600-2,000
KL3586CB-9	9.00mm	.354 - .030	1,400-1,800
KL3591CB-9	10.0mm	.394 - .030	1,200-1,600
KL1749CB-9	11.0mm	.437 - .030	1,000-1,400
STANDARD CARBIDE BORING REAMERS FOR CAST IRON GUIDES			
KL1719C-9	5/16"	.312 - .030	1,600-2,000
KL1725C-9	11/32"	.343 - .030	1,400-1,800
KL1735C-9	3/8"	.375 - .030	1,300-1,700
KL3566C-9	6.00mm	.236 - .030	2,300-2,700
KL3571C-9	6.60mm	.260 - .030	2,000-2,400
KL3576C-9	7.00mm	.275 - .030	1,900-2,300
KL3581C-9	8.00mm	.315 - .030	1,600-2,000
KL3586C-9	9.00mm	.354 - .030	1,400-1,800
BLACK BEAUTY® CARBIDE BORING REAMERS FOR BRONZE GUIDES			
KL3519CSP	5/16"	.312 - .030	1,600-2,000
KL3525CSP	11/32"	.343 - .030	1,400-1,800
KL3535CSP	3/8"	.375 - .030	1,300-1,700
KL3561CSP	5.50mm	.216 - .030	2,500-2,900
KL3566CSP	6.00mm	.236 - .030	2,300-2,700
KL3571CSP	6.60mm	.260 - .030	2,000-2,400
KL3576CSP	7.00mm	.275 - .030	1,900-2,300
KL3581CSP	8.00mm	.315 - .030	1,600-2,000
GUIDE PRO® SOLID CARBIDE BLACK BEAUTY® BORING REAMERS FOR HARDENED POWDERED METAL GUIDES			
KL3556CC	5.00mm	.197 - .030	2,700-3,100
KL3561CC	5.50mm	.216 - .030	2,500-2,900
KL3566CC	6.00mm	.236 - .030	2,300-2,700
KL3576CC	7.00mm	.275 - .030	1,900-2,300
KL3581CC	8.00mm	.315 - .030	1,600-2,000
KL3586CC	9.00mm	.354 - .030	1,400-1,800
KL1719CC	5/16"	.312 - .030	1,600-2,000
KL1725CC	11/32"	.343 - .030	1,400-1,800
KL1735CC	3/8"	.375 - .030	1,300-1,700
BRONZE VALVE GUIDE FINISH REAMERS			
KL1185NB	5.50mm	0.2165	800-1200
KL1110NB	6.00mm	0.2360	750-1150
KL1173NB	6.60mm	0.2600	700-1100
KL1111NB	7.00mm	0.2755	700-1000
KL1116NB	7.87mm	0.3100	600-900
KL1117NB	7.90mm	0.3110	600-900
KL1118NB	5/16"	0.3120	600-900
KL1176NB	7.95mm	0.3130	600-900
KL1177NB	7.98mm	0.3140	600-900
KL1112NB	8.00mm	0.3150	600-900
KL1174NB	8.03mm	0.3160	600-900
KL1175NB	8.05mm	0.3170	600-900
KL1119NB	8.66mm	0.3410	500-800
KL1120NB	8.69mm	0.3420	500-800
KL1121NB	8.71mm	0.3430	500-800
KL1122NB	11/32"	0.3440	500-800
KL1123NB	8.76mm	0.3450	500-800
KL1113NB	9.00mm	0.3543	500-800
KL1124NB	9.42mm	0.3710	400-700
KL1125NB	9.45mm	0.3720	400-700
KL1126NB	9.47mm	0.3730	400-700
KL1127NB	9.50mm	0.3740	400-700
KL1128NB	3/8"	0.3750	400-700
KL1193NB	9.58mm	0.3770	400-700
KL1182NB	9.60mm	0.3780	400-700

K-LINE® REAMER RPM BY TYPE AND SIZE

K-LINE REAMER #	NOMINAL	SIZE	RPM RANGE
HIGH-SPEED STEEL FINISH REAMERS FOR CAST IRON GUIDES			
KL1060	5.00mm	0.1970	900-1300
KL1061	5.44mm	0.2140	800-1200
KL1062	5.46mm	0.2150	800-1200
KL1185	5.50mm	0.2165	800-1200
KL1063	5.51mm	0.2170	800-1200
KL1064	5.54mm	0.2180	800-1200
KL1199	5.94mm	0.2340	750-1150
KL1216	5.97mm	0.2350	750-1150
KL1110	6.00mm	0.2362	750-1150
KL1217	6.02mm	0.2370	750-1150
KL1115	1/4"	0.2500	700-1100
KL1207	6.55mm	0.2580	700-1100
KL1208	6.58mm	0.2590	700-1100
KL1173	6.60mm	0.2600	700-1100
KL1157	6.96mm	0.2740	700-1000
KL1111	7.00mm	0.2756	700-1000
KL1214	7.01mm	0.2760	700-1000
KL1148	7.03mm	0.2770	700-1000
KL1187	9/32"	0.2810	700-1000
KL1117	7.90mm	0.3110	600-900
KL1118	5/16"	0.3120	600-900
KL1176	7.95mm	0.3130	600-900
KL1177	7.97mm	0.3140	600-900
KL1112	8.00mm	0.3150	600-900
KL1174	8.03mm	0.3160	600-900
KL1175	8.05mm	0.3170	600-900
KL1178	8.08mm	0.3180	600-900
KL1188	8.31mm	0.3270	500-800
KL1210	8.64mm	0.3400	500-800
KL1119	8.66mm	0.3410	500-800
KL1120	8.69mm	0.3420	500-800
KL1121	8.71mm	0.3430	500-800
KL1180	11/32"	0.3435	500-800
KL1122	8.74mm	0.3440	500-800
KL1123	8.76mm	0.3450	500-800
KL1136	8.79mm	0.3460	500-800
KL1181	8.81mm	0.3470	500-800
KL1190	8.97mm	0.3530	500-800
KL1113	9.00mm	0.3542	500-800
KL1191	9.02mm	0.3550	500-800
KL1192	9.04mm	0.3560	500-800
KL1215	9.06mm	0.3570	500-800
KL1138	9.09mm	0.3580	500-800
KL1125	9.45mm	0.3720	450-750
KL1126	9.47mm	0.3730	450-750
KL1127	9.50mm	0.3740	450-750
KL1128	3/8"	0.3750	450-750
KL1139	9.55mm	0.3760	450-750
KL1193	9.58mm	0.3770	450-750
KL1182	9.60mm	0.3780	450-750
KL1209	9.63mm	0.3790	450-750
KL1194	9.65mm	0.3800	450-750
KL1213	9.68mm	0.3810	450-750
KL1196	9.86mm	0.3880	450-700
KL1197	25/64"	0.3900	450-700
KL1205	9.98mm	0.3930	450-700
KL1114	10.0mm	0.3937	450-700

ALPHABETICAL INDEX

NOTE: ALL PAGE NUMBERS LISTED BELOW ARE FOR THE K-LINE SECTION OF CATALOG ONLY

A

Air Hammer Ball Broach Holder/Driver 12

B

Ball Broaches 12

BLACK BEAUTY

Carbide Boring Tools 9, 10

Boring Bushing Kits 6

BORING STAND

Accessories/Replacement Parts 8

Boring Tools 9, 10

Bronze Bullet® Auto Installers 11

BRONZE BULLET® GUIDE-LINER® KITS

NX Deluxe Air Installation Kits 7

RX Standard Air Installation Kits 6

BRONZE BULLET® GUIDE-LINERS®

5-step installation procedure 3

Bored Hole Tolerances 5

Instructional Video 3

Interrupted Spiral 4, 5

Fractional Sizes 4

Millimeter Sizes 4, 5

Smooth Wall 5

Fractional Sizes 5

Millimeter Sizes 5

Bronze Lube 11

Bronze Valve Guide Finish Reamers 16

C

Carbide Boring Tools 9, 10

CUTTERS

Guide-Top 13

D

DRIVERS

Air Hammer Ball Broach Driver 12

Stem Seal 22

F

FINISH REAMERS

Bronze Valve Guide 16

H.S.S. Cast Iron 17

Flex-Hones® 14

G

GAUGES

Go-No-Go 10

GUIDE-LINER®

Guide-Liners® 4, 5

Guide-Top Cutters 13

Installation Kits 6, 7

Removal Tool 14

Trimming Tool 13

Guide Pro® Boring Tools 10

H

High-Speed Steel Guide Reamers 17

L

LUBRICANTS

Bronze Lube 11

O

Oil - Bronze & Arbor 11

R

Reamer Bushings 9

Reamer Oil 11

REAMERS

Boring 9, 10

Bronze Valve Guide 16

H.S.S. Valve Guide (Cast Iron) 17

S

Seals - Valve Stem 15

Stem Seal Driver 15

T

TOOL KITS

Bronze Bullet® Guide-Liner® 6, 7

V

VALVE GUIDE

Boring Bushing Kits 6

Boring Fixture Kit 8

Cutters 13

Fixture Stand 8

V

(Continued)

VALVE GUIDE

Flex-Hones® 5

Reamers 16, 17

Valve Guide Boring Fixture 8

Valve Guide-Liner® Kits 6, 7

Valve Guide-Liners® 4, 5

Valve Seals - Steel-Grip® 15

VALVE SEAT

Bushing Kits 6

VIDEOS

Bronze Bullet® Guide-Liner® Installation 3

NUMERICAL PAGE INDEX

KL1036	6, 7	KL1174NB	16	KL1408 (USE 322-1023).	15	KL1842A	5
KL1060	17	KL1175	17	KL1408A (USE 322-1023).	15	KL1842STA	4
KL1061	17	KL1175NB	16	KL1424A (USE 122-1223).	15	KL1845A	5
KL1062	17	KL1176	17	KL1425 (USE 122-1224).	15	KL1849STA	4
KL1063	17	KL1176NB	16	KL1425A (USE 122-1224).	15	KL1850A	5
KL1064	17	KL1177NB	16	KL1427A (USE 122-1400).	15	KL1850STA	4
KL1110	17	KL1178	17	KL1428A (USE 122-1221).	15	KL1851STA	4
KL1110NB	16	KL1180	17	KL1429 (USE 122-9003).	15	KL1852STA	4
KL1111	17	KL1181	17	KL1430 (USE 122-9004).	15	KL1856STA	4
KL1111NB	16	KL1182	17	KL1431 (USE 122-9005).	15	KL1857STA	4
KL1112	17	KL1182NB	16	KL1600NX	7	KL1858STA	4
KL1112NB	16	KL1185	17	KL1600RX	6	KL1860A	5
KL1113	17	KL1185NB	16	KL1601NX	7	KL1861A	5
KL1113NB	16	KL1187	17	KL1601RX	6	KL1897	6, 13
KL1114	17	KL1188	17	KL1602NX	7	KL1900STA	4
KL1115	17	KL1190	17	KL1602RX	6	KL1902STA	4
KL1116NB	16	KL1191	17	KL1606NX	7	KL1903STA	4
KL1117	17	KL1192	17	KL1606RX	6	KL1904STA	4
KL1117NB	16	KL1193	17	KL1607NX	7	KL1905STA	4
KL1118	17	KL1193NB	16	KL1607RX	6	KL1906STA	4
KL1118NB	16	KL1194	17	KL1608NX	7	KL1909STA	4
KL1119	17	KL1196	17	KL1608RX	6	KL1920STA	5
KL1119NB	16	KL1197	17	KL1609NX	7	KL1921STA	4
KL1120	17	KL1199	17	KL1609RX	6	KL1923STA	4
KL1120NB	16	KL1205	17	KL1610NX	7	KL1925STA	5
KL1121	17	KL1207	17	KL1611NX	6	KL1927STA	4
KL1121NB	16	KL1208	17	KL1612NX	7	KL1932STA	4
KL1122	17	KL1209	17	KL1612RX	6	KL1933STA	4
KL1122NB	16	KL1210	17	KL1613NX	7	KL1937STA	4
KL1123	17	KL1213	17	KL1614NX	6	KL1939STA	4
KL1123NB	16	KL1214	17	KL1614RX	7	KL1940STA	4
KL1124NB	16	KL1215	17	KL1719C-9	6, 9	KL1942STA	4
KL1125	17	KL1216	17	KL1719CB-9	7, 9	KL1944STA	4
KL1125NB	16	KL1217	17	KL1719CC	10	KL1961STA	4
KL1126	17	KL1224	11	KL1725C-9	6, 9	KL1967STA	4
KL1126NB	16	KL1225	11	KL1725CB-9	7, 9	KL1968STA	4
KL1127	17	KL1400A (USE 122-1399).	15	KL1725CC	10	KL1974STA	4
KL1127NB	16	KL1401G (USE 122-9000).	15	KL1735C-9	6, 9	KL1975STA	4
KL1128	17	KL1402 (USE 322-1020).	15	KL1735CB-9	7, 9	KL1983STA	4
KL1128NB	16	KL1402A (USE 322-1020).	15	KL1735CC	10	KL1988STA	5
KL1136	17	KL1402F (USE 122-9001).	15	KL1749CB-9	7, 9	KL1992STA	4
KL1138	17	KL1403F (USE 122-9002).	15	KL1787	6, 13	KL1997STA	4
KL1139	17	KL1404 (USE 322-1019).	15	KL1797	6, 13	KL1999STA	4
KL1148	17	KL1404A (USE 322-1019).	15	KL1807	6, 13	KL2419	7, 14
KL1157	17	KL1405 (USE 322-1021).	15	KL1840A	5	KL2422	7, 14
KL1173	17	KL1406A (USE 322-1022).	15	KL1840STA	4	KL2424	7, 14
KL1173NB	16	KL1406 (USE 322-1022).	15	KL1841A	5	KL2425	7, 14
KL1174	17	KL1405A (USE 322-1021).	15	KL1841STA	4	KL2426	7, 14

NUMERICAL PAGE INDEX

KL2427	7, 14	KL4234	.13	KL5837	6, 7, 12	KL9912	6
KL2428	7, 14	KL4235	.13	KL5838	6, 7, 12	KL9913	6
KL2429	7, 14	KL4236	.13	KL5839	.12	KL9914	6
KL2430	7, 14	KL4237	.13	KL5840	.12	KL9915	6
KL2498	7, 10	KL4238	.13	KL5842	.12	KL9916	6
KL2499	7, 10	KL4239	.13	KL5843	.12	KL9917	6
KL2500	7, 10	KL4240	.13	KL5844	6, 7, 12	KL9918	6
KL2501	7, 10	KL4241	.13	KL5845	6, 7, 12	KL9919	6
KL2502	7, 10	KL4242	.13	KL5846	6, 7, 12	KL9920	6
KL2503	7, 10	KL4243	.13	KL5847	6, 7, 12	KL9921	6, 7, 9
KL2504	7, 10	KL4244	.13	KL5848	6, 7, 12	KL9922	6, 7, 9
KL2505	7, 10	KL4245	.13	KL5849	6, 7, 12	KL9925	8
KL2506	7, 10	KL4246	.13	KL5850	.12	KL9929	6, 7, 9
KL2507	7, 10	KL4247	.13	KL5851	.12	KL9930	6, 7, 9
KL2508	7, 10	KL4248	.13	KL5852	.12	KL9931	6, 7, 9
KL2514	7, 10	KL5677	7, 14	KL5855	.12	KL9932	6, 7, 9
KL3184	6, 13	KL5678	7, 14	KL5856	.12	KL9933	6, 7, 9
KL3185	6, 13	KL5679	7, 14	KL5857	6, 7, 12	KL9934	6, 7, 9
KL3205	6, 13	KL5680	7, 14	KL5858	6, 7, 12	KL9935	6, 7, 9
KL3235	6, 13	KL5681	7, 14	KL5859	6, 7, 12	KL9936	6, 7, 9
KL3519CSP	9	KL5682	7, 14	KL5860	.12	KL9937	7, 9
KL3525CSP	9	KL5684	7, 14	KL5864	6, 7, 12	KL9939	7, 9
KL3535CSP	9	KL5685	7, 14	KL5865	6, 7, 12	KL9957	6, 7, 11
KL3556CC	6, 7, 10	KL5686	7, 14	KL5866	6, 7, 12	KL9958	6, 7, 11
KL3561CC	6, 7, 10	KL5687	7, 14	KL5869	.12	KL9961	6, 7, 11
KL3561CSP	9	KL5688	7, 14	KL5871	.12	KL9962	6, 7, 11
KL3566C-9	6, 9	KL5689	7, 14	KL5872	6, 7, 12	KL9963	6, 7, 11
KL3566CB-9	7, 9	KL5758	.12	KL5873	6, 7, 12	KL9964	7, 11
KL3566CC	.10	KL5759	.12	KL5874	6, 7, 12	KL9968	6, 7, 11
KL3566CSP	9	KL5759B	.12	KL5876	7, 12	KL9969	6, 7, 11
KL3571C-9	6, 9	KL5808	6, 7, 12	KL5877	7, 12	KL9970	7, 11
KL3571CB-9	7, 9	KL5809	6, 7, 12	KL5878	7, 12	KL9971	6, 7, 11
KL3571CSP	9	KL5810	6, 7, 12	KL5880	7, 12	KL9972	6, 7, 11
KL3576C-9	6, 9	KL5811	6, 7, 12	KL5881	7, 12	KL9973	6, 7, 11
KL3576CB-9	7, 9	KL5813	.12	KL5882	7, 12	KL19100STA	4
KL3576CC	.10	KL5814	.12	KL5889	.12	KL19101STA	4
KL3576CSP	9	KL5815	6, 7, 12	KL5890	.12	KL19103STA	5
KL3581C-9	6, 9	KL5816	6, 7, 12	KL5892	.12	KL19107STA	4
KL3581CB-9	7, 9	KL5817	6, 7, 12	KL5893	.12		
KL3581CC	.10	KL5818	6, 7, 12	KL5901	6, 7, 12		
KL3581CSP	9	KL5819	.12	KL5902	6, 7, 12		
KL3586C-9	6, 9	KL5820	.12	KL5903	6, 7, 12		
KL3586CB-9	7, 9	KL5825	6, 7, 12	KL9900	8		
KL3586CC	.10	KL5826	6, 7, 12	KL9900-25	8		
KL3591CB-9	7, 9	KL5827	6, 7, 12	KL9900-29A	8		
KL4230	.13	KL5834	.12	KL9907	6		
KL4230A	.13	KL5835	6, 7, 12	KL9910	6		
KL4233	.13	KL5836	6, 7, 12	KL9911	6		

MANUFACTURER TRADEMARKS

BLACK BEAUTY®, **BRONZE BULLET®**, **GUIDE-LINER®**, **GUIDE-PRO®**,
INTERRUPTED SPIRAL®, **K-LINE®**, & **STEEL-GRIP®**
are all registered trademarks of K-Line Industries, Inc.

DESMOND® is a registered trademark of Desmond-Stephan Manufacturing Company.

FLEX-HONE® is a registered trademark of Brush Research Manufacturing Company, Inc.

TEFLON® is a registered trademark of DuPont.

Performance and Returns

K-Line tools are manufactured to perform the work for which they are designed and last as long as is consistent with ordinary wear. Any tool defective will be repaired, replaced or a credit issued at our option (transportation charges prepaid). Under no circumstance will claims for labor or other related parts, not of our manufacture, receive consideration. It shall be understood that this performance policy will not apply in the case of any part that shall have been used in any application other than for which it is intended. Claims will not be honored for products of our manufacture which have been altered in any way and or misused by the customer.

© Copyright 2020, K-Line® Industries, Inc. All copy and illustrations contained in this catalog are copyrighted. Absolutely no reproductions or use of any part is allowed without written permission from K-Line.

