

GOODSON

Tools and Supplies for Engine Builders

2024

www.goodson.com • 1-800-533-8010

From The President's Desk

Business is all about relationships. In fact, life is all about relationships.

My wife and I recently celebrated our 30th wedding anniversary. No small feat but it pales in comparison to my uncle and aunt's 70th wedding anniversary celebration just a few months later. My son and his fiancé will begin their married life together in 2024. Whether it's 30 years, 70 years or year one, the same elements necessary for a long, happy marriage are also key to a long, successful business relationship: respect, trust, ownership, and responsiveness. These ideals need to be present each and every day, not just once in a while.

At GOODSON our decades long commitment to our customer has not waived:

- Top notch customer service
- Same-day shipping
- Iron-Clad Guarantee
- Goodson Techxperts at your service
- Full Service ... Fast!

These bullet points aren't new at GOODSON. They embody our core values and, whether you have been our customer for one year, 30 years, or 70 years,



*Roger Schumacher,
Goodson President*

they represent our respect, trust, ownership, and responsiveness in our relationship with you.

GOODSON is closing in on a big anniversary next year, but it will be meaningless if we lose our focus on what is important today. At GOODSON, year 79 is no less important than year 80. Our goal is to make every transaction you have with GOODSON a pleasant experience and one that will make you value your relationship with us. We certainly value our relationship with you!

Thank you for your business!

Do You Have An Idea For The Next Great Product?

Many of the ideas for our most successful new products come directly from you, the guys in the shop. You work in this industry and have come up with some creative solutions to everyday problems. A great case in point is the Bucket Lifter Grinder you'll find over on page 45.

Contact me, Richard Orlikowski, and give me a call to learn more about how you can have Goodson produce and market your new product idea.



*Richard Orlikowski,
Goodson Product Manager*

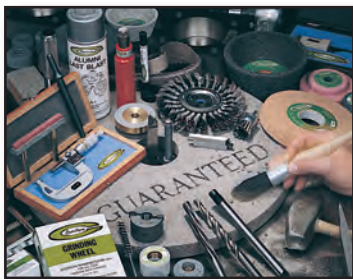

GOODSON Ironclad Guarantee

Goodson won't risk losing your business for any reason. If you're not 100% satisfied with

your purchase, we'll fix it, exchange it or credit your account for the purchase price.

To send an item back, just include a note detailing the reason for the return and ship it back, freight pre-paid within 30 days. The only time we can't honor this guarantee is if a tool has been damaged through misuse or modification. All abrasives have a shelf life so we can only guarantee them for one year from the original purchase date.

Contact Us

Goodson offices are open from 8:00am to 5:00pm, Monday through Friday (Central time).

Phone: 1-800-533-8010 (US & Canada)
1-507-452-1830 (International)

Fax: 1-888-466-3909 (US & Canada)
1-507-452-2907 (International)

Please note that the Goodson offices will be closed in observance of these 2024 holidays: New Year's Day (January 1), Easter (March 29), Memorial Day (May 27), Independence Day (July 4), Labor Day (September 2), Thanksgiving (November 28 & 29), Christmas (December 24 & 25) and New Year's Eve (December 31).

We're always open on the web!

Web: www.goodson.com

Email: orderdesk@goodson.com

New for 2024!

Rimac® Valve Spring Testers

new

Rimac® Valve Spring Testers

- Specifically designed for quick, easy testing of multiple valve springs
- High-torque, lever-actuated compression is key to repeatable precision
- The vertical design ensures stability on the workbench
- Ideal for use in the shop, but portable enough to take to the racetrack
- Calibrated spring set includes two springs with different ranges that can be combined for a range of 10 to 640 lbs.

Description	Order No.
0-500 lb. Tester (reads in 5 lb. increments)	VST-69
0 to 1000 lb. Tester (reads in 2 lb. increments)	VST-70
Calibrated Test Spring Set (2 pc.set)	VST-SPRINGS

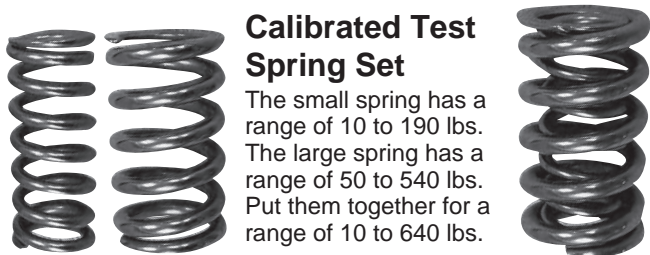

Calibrated Test Spring Set

The small spring has a range of 10 to 190 lbs. The large spring has a range of 50 to 540 lbs. Put them together for a range of 10 to 640 lbs.



RAPIDEX

A rapid-use index of product categories

Cylinder Head Rebuilding

Pilots.....	3-5
Valve Seat Work.....	6-24
Valve Refacing.....	25-29
Reamers.....	30-31
Valve Guide Resizing.....	32-34
Valve Guide Replacement.....	35-39
Valve Seal Work.....	40
Valve Spring Work.....	41-46
Cylinder Head Resurfacing.....	48-51
Crack Detection & Repair.....	52-55
Porting & Polishing.....	58-60

Cleaning, Assembly & Safety

Parts Storage & Organizers.....	61-63
Parts Baskets.....	63
Wire Wheels & Brushes.....	64-65
Cleaning.....	66-69
Last Blast Paint & Metal Markers.....	70
Assembly Lubes.....	71
Coolants & Lubricants.....	72-74

Index	75-82
Flex-Hones®.....	83

Short Block Rebuilding

Boring Bar Tooling & Supplies.....	84-85
Cylinder Honing.....	86-91
Rod Honing.....	92
Rod & Piston Work.....	93-97
Lifter Bore Tooling.....	99
Camshaft Work.....	100-101

Crankshaft/Flywheel Grinding

Crankshaft Grinding Wheels.....	102-103
Crankshaft Grinding & Polishing.....	105-109
Flywheel Grinding.....	110-113

Miscellaneous Tools

Diamond Dresser Tools.....	114-115
Miscellaneous.....	116

Brake Service Tooling

Brake Tips & Holders.....	117-118
Brake Lathe Silencers.....	119
Brake Lathe Replacement Parts.....	120-122

Measuring Tools

Straight Edges.....	123
Dial Bore Gauges.....	125-126
Calipers & Dial Indicators.....	127
Micrometers.....	129

V-Twin Hard Parts

Valve Springs.....	130-132
Seats & Seat Inserts.....	133
Valve Guides.....	134
Replacement Valves.....	135

© Copyright 2024, Goodson Mfg. Co., Inc. All copy and illustrations are copyrighted. Absolutely no mechanical or electronic reproduction or use of any part is allowed without our prior written permission. Goodson reserves the right to correct printing errors. Prices are subject to change without notice.

Policies

See page 84 for more information about these policies.

Pricing:

Prices are subject to change without notice. There is no minimum order. Orders are billed at the prices in effect at the time of shipping. Discounts are not available on select items including Sunnen®, UltraSonic, LLC and QualCast Products.

Shipping:

Goodson typically ships orders the same day they are received. Orders received after 2:00pm (central), on weekends or holidays are shipped the next business day. If your order is lost in shipping, Goodson works with the shipper to provide tracking service. Please inspect all shipments upon receipt and report damage or errors within 48 hours.

Freight:

For orders shipped ground within the USA, you may deduct the freight charges on any **JOBBER** net invoice of \$800 or more if you pay within 30 days of the invoice date. Glass Beads, Steel Shot, Tumbler Media, Machines, Equipment, Bulk Liquids, Cleaning Detergents and Crankwheels are not included. Hazardous Materials, Dangerous Goods & Dimensional Shipping fees may apply on some items.

Terms:

- 1) A 1% discount is given on merchandise if payment is made within 15 days from **invoice** date. This discount applies only to the merchandise amount (not the total amount) on the **invoice** (not a statement). The discount amount is shown in the lower left hand corner of the invoice. This discount does not apply to statement payments and does not apply to credit card orders.
- 2) Balances not paid in full within 30 days are subject to a finance charge of 1.5% per month (18% per year).

Credit & Debit Card Orders:

Goodson accepts MasterCard, Visa, American Express, Discover Card and PayPal. For your security, credit card numbers are **NOT** kept on file. Credit Card and PayPal orders do not qualify for the 1% quick-pay discount.

Check Acceptance:

In the unlikely event that your check is returned for insufficient or held funds, we will debit your checking account electronically for the face amount of the check plus the service fee allowed by your state's law. This allows us to resolve the problem without turning you over to a collection agency and harming your credit rating. The transaction will appear on your bank statement and no one will have to contact you about payment.

Returns:

You may return any item, except special orders, within 60 days. We will do our best to correct any problems or to send a replacement. If an item was damaged through mis-use or modification, Goodson will not accept it as a return. Credits will only be issued after it is determined that the part is resellable or it is deemed defective.

Some Hazardous Materials are Non-returnable due to shipping regulations. See our policies on the last page of the index for more details or call us toll-free at 1-800-533-8010.

ABRASIVES WARRANTY: Abrasives have a shelf life, therefore, all abrasives are warranted against manufacturing defects for 1 year from the date of original purchase.

RESETTING/RESHARPENING SERVICE: Premium Diamonds can be reset and many of our cutting tools, including CBN inserts, FT/VSA cutters and VN-65C can be resharpened. Send your resets and resharps to **GOODSON Tools & Supplies**, ATTN: Resharps, 156 Galewski Dr. Winona, MN 55987. Be sure to include your customer number.



Solid Tapered Pilots

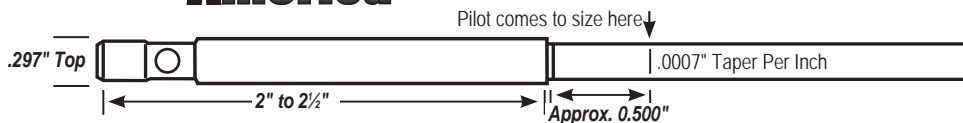

.297" Solid-Tapered High Speed Steel Pilots

Inch	mm	OAL	Order No.	Inch	mm	OAL	Order No.	Inch	mm	OAL	Order No.	Inch	mm	OAL	Order No.
.1574"	4.00	4.50"	P-1158N	.1779"	4.52	4.50"	P-1178N	.2165"	5.50	4.50"	P-1216N	.2500"	6.35	4.50"	P-1250N
.1582"	4.02	4.50"	P-1159N	.1968"	5.00	4.50"	P-1197N	.2362"	6.00	4.50"	P-1236N	.2510"	6.37	4.50"	P-1251N
.1771"	4.50	4.50"	P-1177N	.1976"	5.02	4.50"	P-1198N	.2370"	6.02	4.50"	P-1237N	.2598"	6.60	4.50"	P-1260N

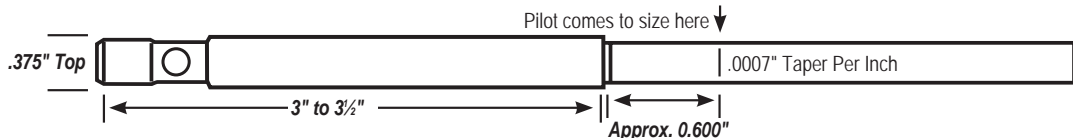

.375" Solid-Tapered High Speed Steel Pilots

Inch	mm	OAL	Order No.	Inch	mm	OAL	Order No.	Inch	mm	OAL	Order No.	Inch	mm	OAL	Order No.
.1771"	4.50	6.00"	P-5177N	.2490"	6.32	6.00"	P-5249N	.2952"	7.50	6.00"	P-5295N	.3417"	8.67	6.50"	P-5341N
.1960"	4.98	6.00"	P-5196N	.2500"	6.35	6.00"	P-5250N	.3095"	7.86	6.00"	P-5309N	.3427"	8.70	6.50"	P-5342N
.1968"	5.00	6.00"	P-5197N	.2559"	6.50	6.00"	P-5256N	.3105"	7.88	6.00"	P-5310N	.3437"	8.72	6.50"	P-5343N
.1976"	5.02	6.00"	P-5198N	.2566"	6.52	6.00"	P-5257N	.3115"	7.91	6.00"	P-5311N	.3447"	8.75	6.50"	P-5344N
.2165"	5.50	6.00"	P-5216N	.2598"	6.60	6.00"	P-5260N	.3125"	7.93	6.00"	P-5312N	.3457"	8.78	6.50"	P-5345N
.2173"	5.52	6.00"	P-5217N	.2748"	6.98	6.00"	P-5274N	.3135"	7.96	6.00"	P-5313N	.3543"	9.00	6.50"	P-5354N
.2185"	5.55	6.00"	P-5218N	.2756"	7.00	6.00"	P-5275N	.3145"	7.98	6.00"	P-5314N	.3551"	9.02	6.50"	P-5355N
.2354"	5.98	6.00"	P-5235N	.2763"	7.02	6.00"	P-5277N	.3149"	8.00	6.00"	P-5315N	.3587"	9.11	6.50"	P-5358N
.2362"	6.00	6.00"	P-5236N	.2775"	7.05	6.00"	P-5278N	.3165"	8.03	6.00"	P-5316N	.3730"	9.47	7.00"	P-5373N
.2370"	6.02	6.00"	P-5237N	.2792"	7.09	6.00"	P-5279N	.3407"	8.65	6.50"	P-5340N	.3740"	9.49	7.00"	P-5374N

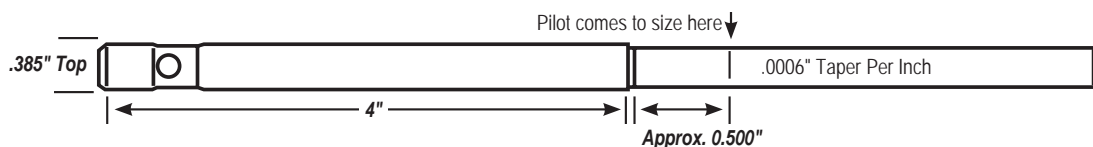

.385" Solid-Tapered High Speed Steel Pilots

Inch	mm	OAL	Order No.	Inch	mm	OAL	Order No.	Inch	mm	OAL	Order No.	Inch	mm	OAL	Order No.
.2165"	5.50	7.50"	P-5216S	.2598"	6.60	7.50"	P-5260S	.3125"	7.94	7.50"	P-5312S	.3420"	8.68	7.50"	P-5342S
.2173"	5.52	7.50"	P-5217S	.2744"	6.97	7.50"	P-5274S	.3130"	7.95	7.50"	P-5313S	.3430"	8.71	7.50"	P-5343S
.2350"	5.97	7.50"	P-5235S	.2755"	7.00	7.50"	P-5275S	.3141"	7.98	7.50"	P-5314S	.3440"	8.73	7.50"	P-5344S
.2362"	6.00	7.50"	P-5236S	.2763"	7.02	7.50"	P-5276S	.3149"	8.00	7.50"	P-5315S	.3450"	8.76	7.50"	P-5345S
.2370"	6.02	7.50"	P-5237S	.2771"	7.04	7.50"	P-5277S	.3161"	8.03	7.50"	P-5316S	.3543"	9.00	7.50"	P-5354S
.2381"	6.05	7.50"	P-5238S	.2779"	7.06	7.50"	P-5278S	.3170"	8.05	7.50"	P-5317S	.3550"	9.02	7.50"	P-5355S
.2500"	6.35	7.50"	P-5250S	.3100"	7.87	7.50"	P-5310S	.3410"	8.66	7.50"	P-5341S	.3560"	9.04	7.50"	P-5356S

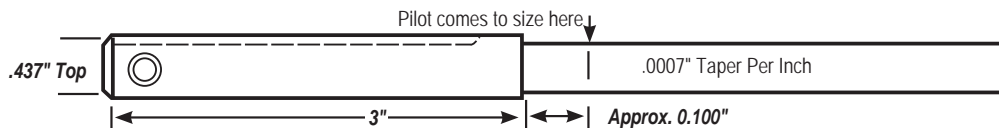

.437" Solid-Tapered High Speed Steel Pilots

Inch	mm	OAL	Order No.	Inch	mm	OAL	Order No.	Inch	mm	OAL	Order No.	Inch	mm	OAL	Order No.
.2165"	5.50	6.75"	P-5216K	.2381"	6.05	6.75"	P-5238K	.3115"	7.90	6.75"	P-5311K	.3150"	8.00	6.75"	P-5315K
.2185"	5.55	6.75"	P-5218K	.2755"	7.00	6.75"	P-5275K	.3125"	7.94	6.75"	P-5312K	.3157"	8.02	6.75"	P-5316K
.2362"	6.00	6.75"	P-5236K	.2763"	7.02	6.75"	P-5276K	.3135"	7.96	6.75"	P-5313K	.3169"	8.05	6.75"	P-5317K
.2370"	6.02	6.75"	P-5237K	.2775"	7.05	6.75"	P-5277K	.3145"	7.98	6.75"	P-5314K	.3427"	8.70	6.75"	P-5342K
												.3437"	8.73	6.75"	P-5343K
												.3750"	9.52	6.75"	P-5375K

CYLINDER HEAD
REBUILDING

ASSEMBLY & SAFETY
CLEANING

SHORT BLOCK
REBUILDING

FLYWHEEL GRINDING
CRANKSHAFT/

MISCELLANEOUS
TOOLS & SUPPLIES

BRAKE SERVICE
TOOLING

MEASURING
TOOLS

V-TWIN & METRIC
HARD PARTS



Every Expanding Pilot Comes Complete With A Collet & Expander

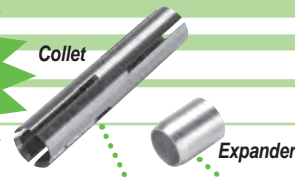

CYLINDER HEAD REBUILDING



.375" Top Expanding Pilots

- Includes Collet & Expander • Expand up to .020" (.51mm)
- High Speed Steel

Size	mm	Range	OAL	Pilot	Collet	Expander
.216"	5.50	.213"-.233"	5.875"	P-5.5MMNX	P-216-COLLET	P-1216-EXP
.236"	6.00	.233"-.253"	5.813"	P-6MMNX	P-6MM-COLLET	P-1236-EXP
.256"	6.50	.253"-.273"	5.875"	P-6.5MMNX	P-6.5MM-COLLET	P-6.5MM-EXP
.275"	7.00	.272"-.292"	6.250"	P-7MMNX	P-7MM-COLLET	P-7MM-EXP
.312"	7.92	.309"-.329"	6.500"	P-312NX	P-312-COLLET	P-343-EXP
.335"	8.50	.330"-.350"	6.500"	P-8.5MMNX	P-343-COLLET	P-343-EXP
.343"	8.70	.340"-.360"	7.063"	P-343NX	P-343-COLLET	P-343-EXP
.375"	9.50	.372"-.392"	7.000"	P-375NX	P-375-COLLET	P-375-EXP
.393"	10.00	.390"-.410"	6.875"	P-10MMNX	P-10MM-COLLET	P-10MM-EXP
.437"	11.00	.430"-.450"	—	—	P-11MM-COLLET	P-11MM-EXP
.472"	12.00	.469"-.489"	—	—	P-12MM-COLLET	P-12MM-EXP

CLEANING, ASSEMBLY & SAFETY



.375" Extended Length Expanding Pilots

- Includes Collet & Expander • Expand up to .020" (.51mm)
- High Speed Steel

Size	mm	Range	OAL	Pilot	Collet	Expander
.3120"	7.92	.309"-.329"	7.750"	P-312NXL	P-312L-COL	P-343-EXP
.3430"	8.71	.340"-.360"	7.750"	P-343NXL	P-343L-COL	P-343-EXP
.3750"	9.52	.372"-.392"	7.813"	P-375NXL	P-375L-COL	P-375-EXP

SHORT BLOCK REBUILDING

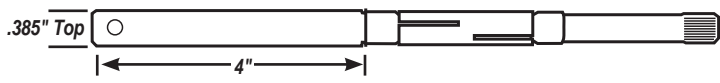

.385" Top Expanding Pilots

- Includes Collet & Expander • Expand up to .020" (.51mm)
- High Speed Steel

Size	mm	Range	OAL	Pilot	Collet	Expander
.236"	6.00	.233"-.253"	7.375"	P-6MMSX	P-6MM-COLLET	P-1236-EXP
.256"	6.50	.253"-.273"	—	—	P-65MM-COLLET	P-6.5MM-EXP
.275"	7.00	.272"-.292"	7.750"	P-7MMSX	P-7MM-COLLET	P-7MM-EXP
.312"	7.92	.309"-.329"	8.000"	P-312SX	P-312-COLLET	P-343-EXP
.343"	8.70	.340"-.360"	8.000"	P-343SX	P-343-COLLET	P-343-EXP
.375"	9.50	.372"-.392"	8.000"	P-375SX	P-375-COLLET	P-375-EXP
.393"	10.00	.390"-.410"	7.875"	P-10MMSX	P-10MM-COLLET	P-10MM-EXP
.406"	10.30	.403"-.423"	8.000"	P-406SX	P-10MM-COLLET	P-10MM-EXP
.437"	11.00	.430"-.450"	8.000"	P-11MMSX	P-11MM-COLLET	P-11MM-EXP
.453"	11.50	.450"-.470"	7.875"	P-453SX	P-12MM-COLLET	P-11MM-EXP
.472"	12.00	.469"-.489"	8.500"	P-12MMSX	P-12MM-COLLET	P-12MM-EXP
.500"	12.70	.497"-.517"	8.438"	P-500SX	P-12MM-COLLET	P-12MM-EXP

CRANKSHAFT/ FLYWHEEL GRINDING

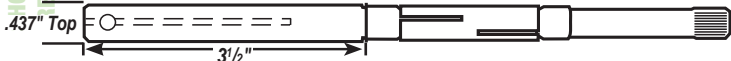

.437" Top Expanding Pilots

- Includes Collet & Expander • Expand up to .020" (.51mm)
- High Speed Steel

Size	mm	Range	OAL	Pilot	Collet	Expander
.236"	6.00	.233"-.253"	6.750"	P-6MMKX	P-6MM-COLLET	P-1236-EXP
.275"	7.00	.272"-.292"	7.250"	P-7MMKX	P-7MM-COLLET	P-7MM-EXP
.312"	7.92	.309"-.329"	7.500"	P-312KX	P-312-COLLET	P-343-EXP
.343"	8.70	.340"-.360"	7.563"	P-343KX	P-343-COLLET	P-343-EXP
.375"	9.50	.372"-.392"	7.500"	P-375KX	P-375-COLLET	P-375-EXP
.453"	11.50	.450"-.470"	7.875"	P-453KX	P-11.5MM-COLLET	P-11MM-EXP

MISCELLANEOUS TOOLS & SUPPLIES

.0007" taper per inch

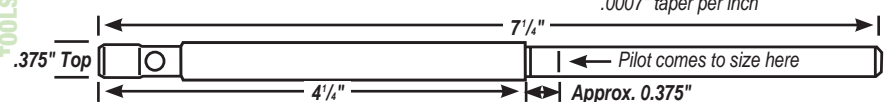

Extended Length (7 1/4") .375" Top Solid-Tapered High Speed Steel Pilots

Inch	mm	OAL	Order No.	Inch	mm	OAL	Order No.
.2755"	7.00	7.25"	P-5275NL	.3437"	8.73	7.75"	P-5343NL
.2756"	7.01	7.25"	P-5276NL	.3447"	8.75	7.75"	P-5344NL
.3145"	7.98	7.25"	P-5314NL	.3457"	8.78	7.75"	P-5345NL
.3150"	8.00	7.25"	P-5315NL	.3740"	9.50	7.75"	P-5374NL
.3417"	8.68	7.75"	P-5341NL	.3750"	9.52	7.75"	P-5375NL
.3427"	8.70	7.75"	P-5342NL				

BRAKE SERVICE TOOLING

MEASURING TOOLS

V-TWIN & METRIC HARD PARTS

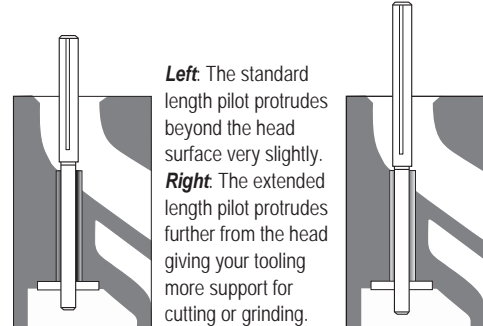

Left: The standard length pilot protrudes beyond the head surface very slightly.
Right: The extended length pilot protrudes further from the head giving your tooling more support for cutting or grinding.

Setting your expanding pilot

tech tips from the techxperts™

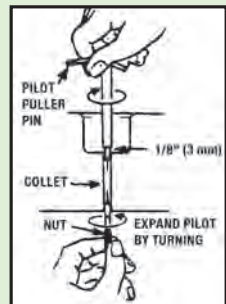

- 1 Select an expanding pilot that is the same diameter as the valve guide ID.
- 2 Insert the pilot into the valve guide making sure that the expanding section of the pilot (collet) is completely within the valve guide. The pilot will not center properly and may be damaged if the collet extends outside of the valve guide.
- 3 Pilot shoulder should be about 1/8" above the valve guide.
- 4 Hold the pilot while turning the nut at the opposite end. This will expand the collet and secure the pilot into position.

NOTE: DO NOT use Expanding Pilots with multi-angle valve seat cutting systems (ie: 3-D Fast Cut)

Carbide, Dresser & Specialty Pilots

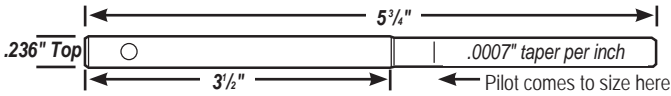

.236" Top Tapered Carbide Pilots

- Less deflection under stress • Due to the brittle nature of carbide we can only warranty carbide pilots for size

Inch	mm	Order No.	Inch	mm	Order No.	Inch	mm	Order No.
.1559"	3.96	PCT-1560M	.1759"	4.47	PCT-1760M	.2560"	6.50	PCT-2560M
.1566"	3.98	PCT-1570M	.1771"	4.50	PCT-1770M	.2570"	6.53	PCT-2570M
.1575"	4.00	PCT-1575M	.1968"	5.00	PCT-1970M	.2578"	6.55	PCT-2580M
.1578"	4.01	PCT-1580M	.2161"	5.49	PCT-2160M	.2763"	7.02	PCT-2765M

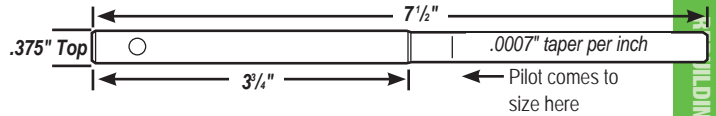

.375" Top Tapered Carbide Pilots

- Less deflection under stress • Due to the brittle nature of carbide we can only warranty carbide pilots for size

Inch	mm	Order No.	Inch	mm	Order No.	Inch	mm	Order No.
.1968"	5.00	PCT-1970	.2756"	7.00	PCT-2756	.3150"	8.00	PCT-3150
.2165"	5.50	PCT-2165	.2759"	7.01	PCT-2760	.3433"	8.72	PCT-3430
.2173"	5.52	PCT-2170	.2763"	7.02	PCT-2765	.3440"	8.73	PCT-3440
.2362"	6.00	PCT-2362	.2771"	7.04	PCT-2770	.3740"	9.50	PCT-3740
.2370"	6.02	PCT-2370	.3122"	7.93	PCT-3120			



Valve Seat Wheel Dresser Pilots for Universal & Heavy Duty Wheel Dressing Stands

- All pilots have a .625" bottom • Dressing stands, page 24

Dresser Pilots (select based on stone holder type)		
Fits Stone Holder Type	OAL	Order No.
A .437" Hex Stone Holder	5 5/8"	031-1102-89
B .437" Hex or Flex Stone Holder	7 1/4"	031-0202-80
C .385" Top Stone Holder	6"	031-0202-55
D .375" Top Stone Holder	6 3/4"	031-0202-47

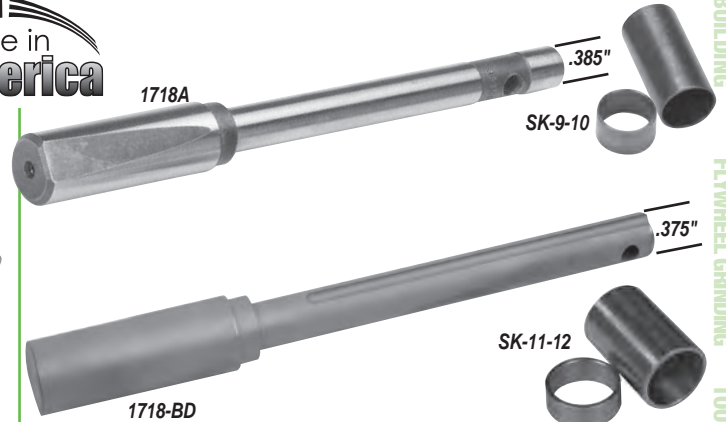

Sioux-Style Dresser Stand Pilots & Bushings

- Replacement parts for the popular 1716 Seat Wheel Dresser no longer available from Sioux™
- .375" top pilot features a groove to fit Black & Decker holders • .600" bottom size

Description	Order No.
.385" Top Pilot, .600" Bottom Size	1718A
.375" Top Pilot, .600" Bottom Size	1718-BD
Dressing Stand Bushings (2) for .375" & .385" Pilots	SK-9-10
Dressing Stand Bushings (2) for .572" Pilots	SK-11-12

Specialty Pilots



3/16" Shank Pilots for Valve Guide Top Cutters

Size	Order No.
.312" (7.93mm)	GFP-312
.343" (8.73mm)	GFP-343
.375" (9.53mm)	GFP-375
.437" (11.11mm)	GFP-437
.500" (12.70mm)	GFP-500

See page 33 for Valve Guide Top Cutters



Valve Guide Pilots for Seal & Seat Cutting

Hardened & Ground Pilots			
Guide ID		Order No.	
.275"	7.0	VP-7MM	
.312"	7.9	VP-312	
.343"	8.7	VP-343	
.375"	9.5	VP-375	

See pages 36 and 46 for Applications

Replaceable Pilots for Adjustable Valve Guide Driver

Diameter	Order No.
.312"	AVG-312
.343"	AVG-343
.372"	AVG-372
.437"	AVG-437
5.0mm	AVG-5MM
5.5mm	AVG-55MM

See page 36 for More Sizes & Tooling

CYLINDER HEAD BUILDING
CLEANING, ASSEMBLY & SAFETY
SHORT BLOCK REBUILDING
CRANKSHAFT/ FLYWHEEL GRINDING
MISCELLANEOUS TOOLS & SUPPLIES
BRAKE SERVICE TOOLING
MEASURING TOOLS
V-TWIN & METRIC HARD PARTS

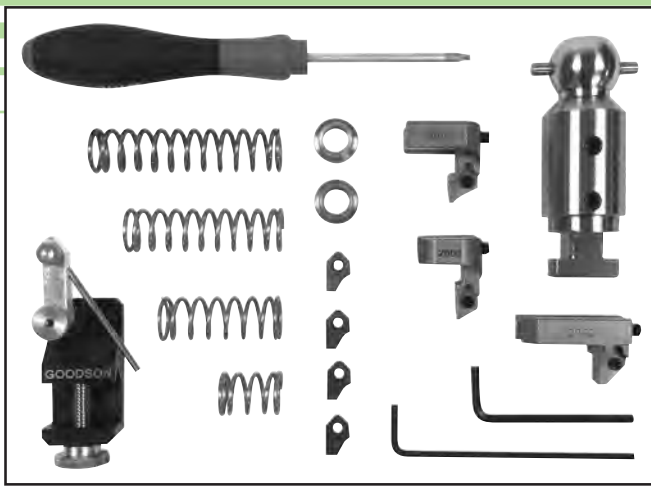

3-D Fast Cut™ Starter Kits

- Can be used with your existing solid taper pilots
- Ball heads are available to fit most common seat grinder pilots
- Choose from over 100 3-angle blade profiles on pages 8-11
- Fully compatible with most popular 3-angle cutting systems including Kwik-Way®, Peterson, Rottler, Serdi, Sunnen®, T&S, Winona Van Norman®, Newen®, etc. • Use between 50 and 100 RPM • Goodson recommends starting at 60 RPM

Description	Fits Pilot		Order No.	Includes
Complete Starter Kits	.375" / 9.53mm		3D-375-KIT	▼
(See page 3 & 5 for pilots)	.385" / 9.78mm		3D-385-KIT	▼
Ball Head Standard	.375" / 9.53mm	Use with 3D tip holders	3D-BH375	x
3.346" long	.385" / 9.78mm	Use with 3D tip holders	3D-BH385	x
	.390" / 9.90mm	Use with 3D tip holders	3D-BH390	
	.375" / 9.53mm	Use with SGM tip holders	3D-BH-SUN375	
Ball Head Extended	.375" / 9.53mm	Use with 3D tip holders	3D-BH375L	
Length 3.80" long				
Ball Head Wide Body	.375" / 9.53mm	Use with 3D tip holders	3D-BH375W	
4.0625" long				
Serdi-Style Tool Bodies	Use with Serdi-style pilots			
4" long	Standard .375" / 9.53mm		SER-5100	
	Large Body .375" / 9.53mm		SER-5300	
Sunnen Style Drive Adaptor for VGS-20			3D-SUN	
Tip Holders	.709" - 1.181" / 18-30mm Range		3D-2000	x x
(Includes	1.02" - 1.653" / 26-42mm Range		3D-2001	x x
FT-SCREW)	1.575" - 2.362" / 40-60mm Range		3D-2002	x x
Tip Holders-Wide Body	1.575" - 2.362" / 40-60mm Range		3D-2003	
	2.385" - 3.150" / 58-80mm Range		3D-2004	
Cutters	45°/1.0mm		FT-45039V1	x x
	45°/1.3mm		FT-45051V1	x x
more on	45°/1.5mm		FT-45059V1	x x
pages 8-11	45°/1.9mm		FT-45075V1	x x
Tool Setting Fixture - All Steel Construction			3D-TSFA	x x
Cutter Blade Mounting Screw			FT-SCREW	
Blade Wrench			FT-WRENCH	x x
Automotive Bounce Spring Set (4 Pc.)			3D-SS4	x x
Bushing Set (1 pair)	.375"		3D-DB7	x
	.385"		3D-DB6	x
Ball Head Driver	#3 Morse Taper Driver		3D-CM3	
	Bridgeport & DCM Driver		3D-3/4SS	
3-D Fast Cut™ Accessories				
Lift Clip for Enhanced Control, especially on Spring Pad Cutters (pg. 12)			3D-CLIP	
Replacement 3.0mm Allen Key			3D-3.0	x x
Replacement 2.5mm Allen Key			3D-2.5	x x
Replacement Screws for NWN Ball Head Base (5 Pack) - metric			MGA-4X5MM	
Replacement Base Screw for Standard Ball Heads M5x6MM			3D-56	
Replacement Base Screw for Wide Body Ball Heads M6x6MM			3D-66	
Replacement Side Screw for Standard Ball Heads M6x8MM, Brass Tip			3D-68	
Replacement Side Screw for Wide Body Ball Heads M6x16MM, Brass Tip			3D-615	
Adjusting Screw for Tip Holder #3D-2000, OAL: .395" /10mm			3D-2000-S	
Adjusting Screw for Tip Holder #3D-2001, OAL: .475" /12mm			3D-2001-S	
Adjusting Screw for Tip Holder #3D-2002, OAL: .625" /15.9mm			3D-2002-S	

See page 7 for Valve Seat Removal Tooling for the 3-D Fast Cut™ System

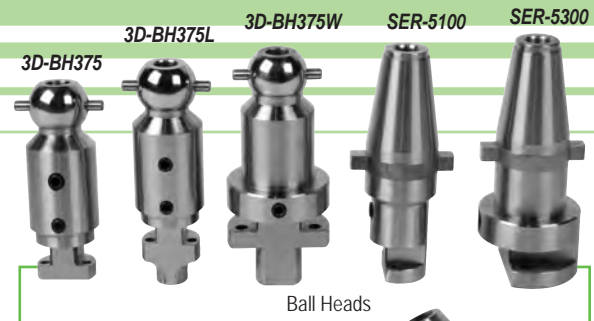

Ball Heads



Watch an overview of the 3-D Fast Cut™ System in our Tech Lab Tuesday video. Scan the code below with your smart phone for quick access.

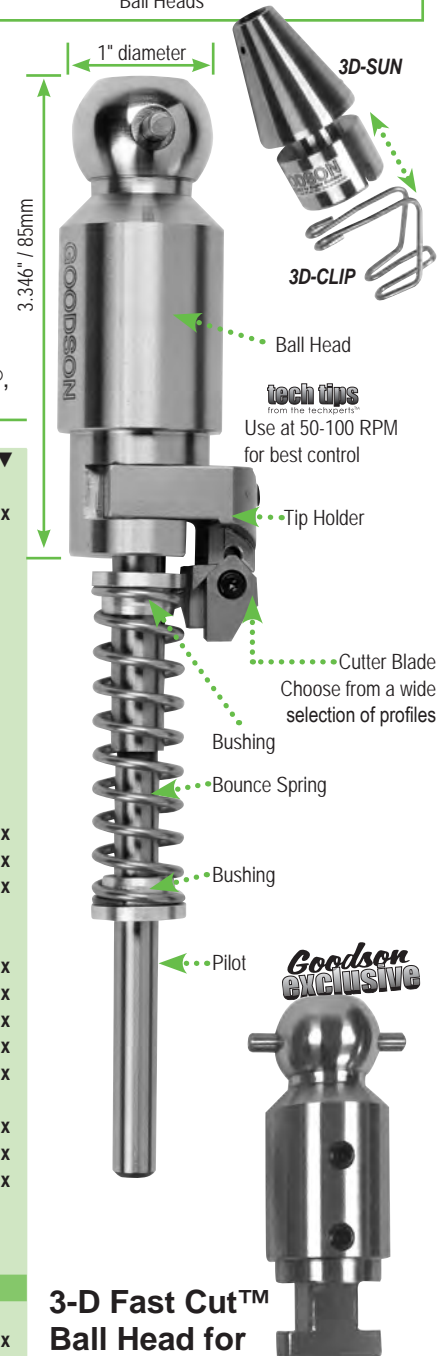

3-D Fast Cut™ Ball Head for Sunnen® Tool Holders

- Fits .375" Top pilots
- Channel measures .500"
- Use with insert holders SGM-1045, SGM-1055, SGM-1090 and SGM-1115
- 3.350" long x 1.162" diameter
- Order No. 3D-BH-SUN375

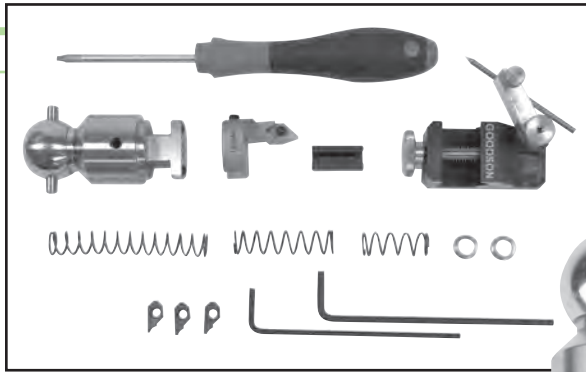

Holders (3DH-1995 & 3DH-1999M) have been modified to provide support to cutters without interfering with the bowl diameter.

Micro Tips FTM-190 and FTM-82R6B-HP only fit Tip Holder 3DH-1995

3-D Fast Cut™ System Micro Ball Head Tooling

- Fits the same 1" ball head driver as the original 3-D Fast Cut tooling
- See page 5 for .236" Top Pilots

Description	Order No.	
Micro Ball Head Starter Kit	3D-236-KIT	▼
3D Ball Head for .236"/6mm Pilot (2.56"L)	3D-BH236	x
Micro Cutter Tips 45°/1.0mm	FTM-185	x
See pg. 9 45°/1.0mm	FTM-187	x
for profiles 39°/1.0mm	FTM-188	x
90° (For counterboring)	FTM-190	x
82° Radius Cutter	FTM-82R6B-HP	x
Tip Holders .550"-.984" Range	3DH-1999M	x
(incl. FT-SCREW) .551"-.850" Range	3DH-1995	x
Bounce Springs Short 1.050" / 26.7mm	3D-BS1	x
.340" ID Medium 1.540" / 39.2 mm	3D-BS3	x
.420" OD Long 2.550" / 64.8 mm	3D-BS2	x
Bounce Spring Bushing (1 pair)	3D-BB1	x
Bounce Spring Spacer 22mm long	3D-BB2	x
3-D Fast Cut™ Accessories		
Replacement 2.5mm Hex Key	3D-2.5	x
Replacement Side Screw M5x8MM	3D-58	
Replacement Base Screw M5x5MM	3D-55	
Cutter Blade Mounting Screw	FT-SCREW	
Blade Wrench	FT-WRENCH	x
Tool Setting Fixture	3D-TSFA	x
Bridgeport / DCM Ball Head Driver	3D-3/4SS	

More levels on page 48



VGL-100
(use with your pilot or find a pilot on page 3)

Valve Guide Level

- Graduated vials with satin-chromed, brass protective covers that rotate to close tightly
- Base castings are seasoned, then precision machined and finished on a bearing surface • Replaceable vials
- Adjustable for precise calibration
- 1 division equals .0005" per inch
- Fits pilots from 6mm to .437"

Description	Order No.	Replacement Vial
4" Valve Guide Level (3" vial)	VGL-100	VGL-101

See www.goodson.com for level calibration instructions



Valve Seat Removal Tooling

- Fits most popular 3-angle cutting tools including our popular 3-D Fast Cut™ System, Kwik-Way, Peterson, Rottler, Serdi, T&S, Winona Van Norman, Newen, etc.
- Use to relieve press fit for easier seat removal
- Requires a minimum of 2 cuts
- For precise set up use the **MGA-MIC** (below)

- Tip Holders include one cutting tip and mounting screw (see chart below) • Replacements sold separately
- Ball Head and Drive Tools sold separately (see page 6)

Description	Replacement Tip	Order No.		
Tip Holders	3DB-1999i	3D-1999C		
	3DB-250	3D-2000C		
	3DB-250	3D-2001C		
	3DB-250	3D-2002C		
Wide Body Tip Holders	3DB-250	3D-2003C		
	3DB-250	3D-2004C		
Replacement Tip	fits 3DB-1999C	3DB-1999i		
	fits all BUT 3DB-1999C	3DB-250		
Replacement Screw	for 3DB-1999i	3DB-1999S		
	for 3DB-250	3DS-SCREW		
Cutting Range with Pilot Size				
Holder	.236" Top	.375" Top	.385" Top	.437" Top
3D-1999C	0.960"-1.225"	1.095"-1.360"	1.105"-1.360"	1.157"-1.360"
3D-2000C	1.056"-1.480"	1.194"-1.480"	1.206"-1.480"	1.264"-1.480"
3D-2001C	_____	1.376"-2.000"	1.386"-2.000"	1.450"-2.000"
3D-2002C	_____	1.524"-2.460"	1.544"-2.460"	1.610"-2.460"
3D-2003C	_____	1.680"-2.400"	1.680"-2.400"	_____
3D-2004C	_____	2.280"-3.200"	2.280"-3.200"	_____

.375" Precision
Drill Bushing for
standard or pilot

MGA-MIC-1S
Precision ground
and micro polished
stabilized tool steel



MGA-MIC

3-D Fast Cut Setting Micrometer

- Direct reading micrometer accurate to .001"
- Uses tapered .375" Pilot to match your ball head (sold separately)
- Use to set cutting diameter of 90° carbide cutters when modifying counterbores
- Use the optional calibration standard to ensure your micrometer is reading correctly

Description	Cutting Range	Order No.
Standard Micrometer	0.800" - 2.800"	MGA-MIC
Calibration Standard		MGA-MIC-1S



SABER TOOTH SERIES CUTTER BLADES

**Cutter
Key:**

- I** Intake
- E** Exhaust
- S** Specialty

High Performance Cutter Blades Add 10 to 20 CFM to Cylinder Heads

Designed to increase airflow by as much as 20 CFM, these cutters are intended for certain applications. Generally you should use intake cutters on intakes and exhaust on exhausts, but as with most things, there's always an exception. Experiment to find the right combination for you and your customers.

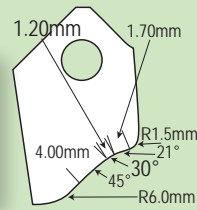

I IFT-30B-HP

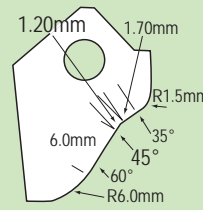

I IFT-4560B-HP

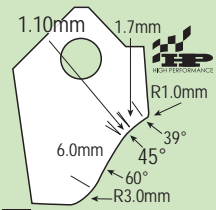

I IFT-4539B-HP

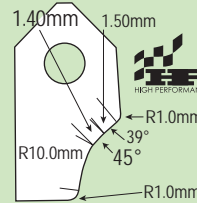

E IFT-4524-HD

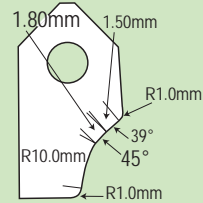

E IFT-4524A-HD

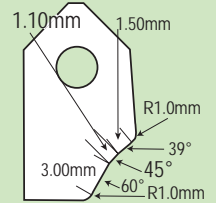

I IFT-4560-HD

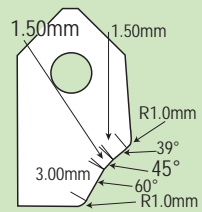

I IFT-4560A-HD

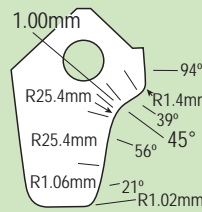

E IFT-4556B-HP

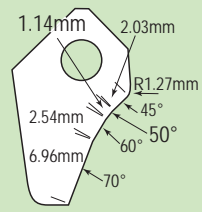

E EFT-5060B-HP

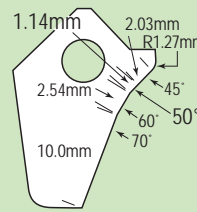

E EFT-5061B-HP

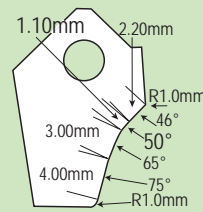

I IFT-5065B-HP

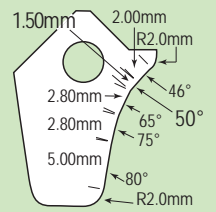

E EFT-5046B-HP

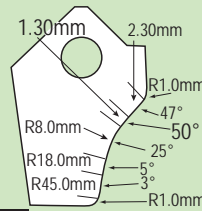

E IFT-5025B-HP

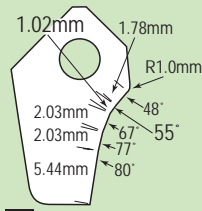

E EFT-5567B-HP

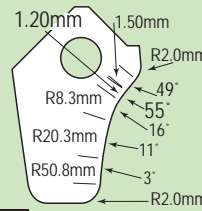

E EFT-5557B-HP

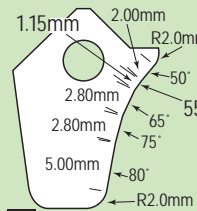

E EFT-5550B-HP

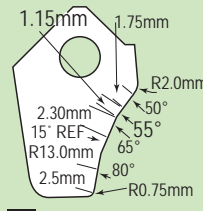

E EFT-5565B-HP

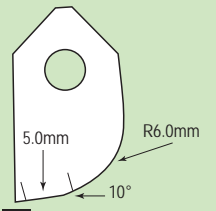

S IFT-1056-HD

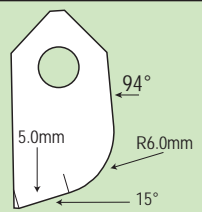

S IFT-1556-HD

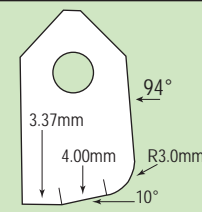

S IFT-1043-HD

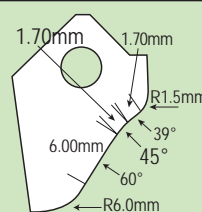

I IFT-45B-HP



SABER TOOTH SERIES CUTTER BLADES

Increase Flow & Improve Horsepower

Enlarged to show details

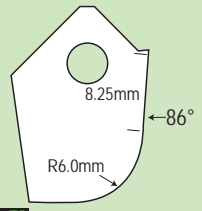

S IFT-86RB-HP

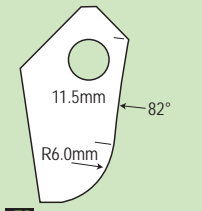

S IFT-82R6B-HP

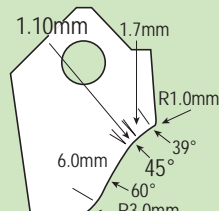

I IFT-4539B-HP
Intake

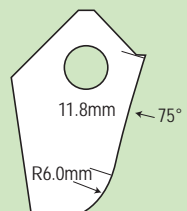

I IFT-75R6B-HP
Follow up Intake

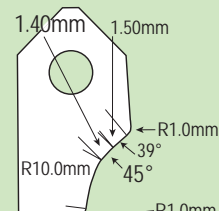

E IFT-4524-HD
Exhaust

3-Pc. Set High Performance Valve Seat Cutters

- Increase flow & improve horsepower with this set
- Machine your intake seat with IFT-4539B-HP then use cutter IFT-75R6B-HP to machine below the seat and blend into the port
- On exhaust, machine with IFT-4524-HD
- Order No. IFT-HP-SET





SABER TOOTH
SERIES CUTTER BLADES

3-D Radius Profile Seat Cutter Blades

3-D Fast Cut Tool Holder

- Use when sharpening cutter blades to keep the cutter in the correct position
- Order No. 3D-HOLDER



Cutter Key:

- I** Intake
- E** Exhaust
- S** Specialty



Diamond Hand Files

- Use for fine touch-up on your Seat Cutter Blades
- Set includes 1-360 grit and 1-600 grit file
- Order No. **DFS-2**

Custom Cutter Blades Are Easy!

- 1 Download the **Goodson Custom Formtool Profile Form** from our website (scan the code at right with the camera on your smart phone or other smart device) or call to have us send a copy.
- 2 Complete the form, including a drawing of the cutter you need. Be sure to include all angles, radii, seat widths, etc. Missing information will delay your cutter or result in an incorrect profile.
- 3 Send the completed form to Goodson. Fax: 888-466-3909 or E-mail: orderdesk@goodson.com. We'll get a blueprint made which you must approve before we start production.



Turn the Page for More Valve Seat Cutter Blades

CYLINDER HEAD REBUILDING
CLEANING, ASSEMBLY & SAFETY
SHORT BLOCK REBUILDING
CRANKSHAFT/ FLYWHEEL GRINDING
MISCELLANEOUS TOOLS & SUPPLIES
BRAKE SERVICE TOOLING
MEASURING TOOLS
V-TWIN & METRIC HARD PARTS

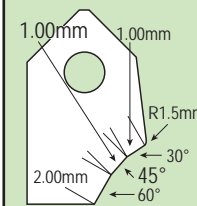

I FT-5043A-HD

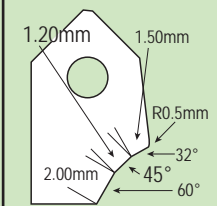

I FT-4247A-HD

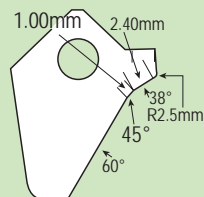

I FT-068B-HP

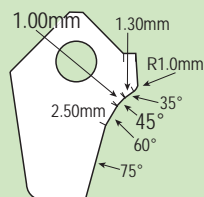

I FT-069B-HP

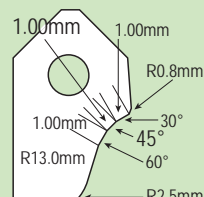

I FT-5118A-HP

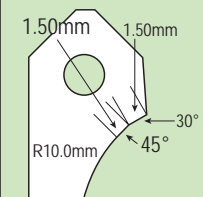

I FT-5119A-HP

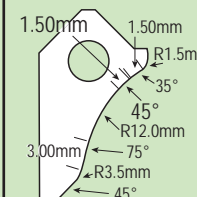

E FT-003B-HP

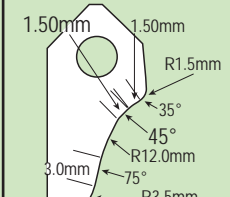

E FT-004B-HP

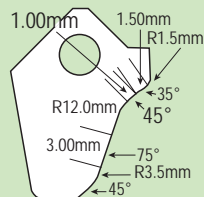

E FT-005B-HP

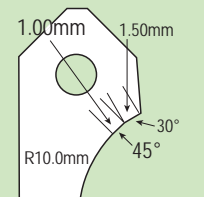

E FT-5120A-HP

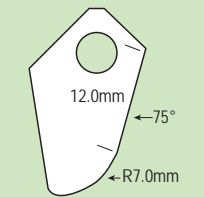

S FT-002B-HP

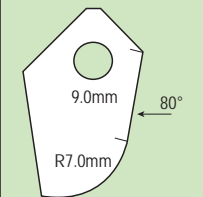

S FT-033B-HP

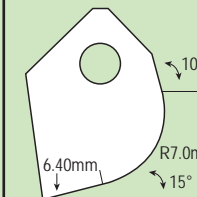

S FT-077B-HP

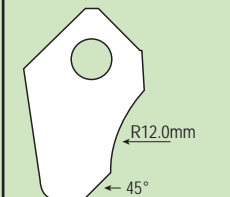

S FT-084B-HP

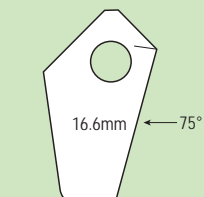

S FT-085B-HP

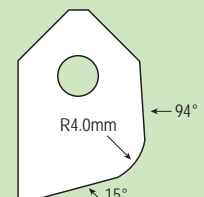

S FT-5121A-HP

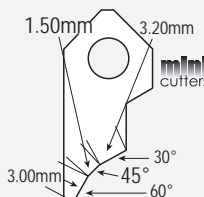

S FT-213B-HP

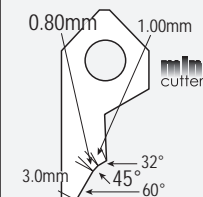

S FT-215B-HP

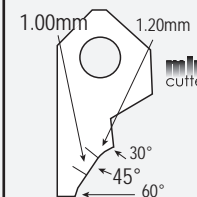

S FT-4028B-HP

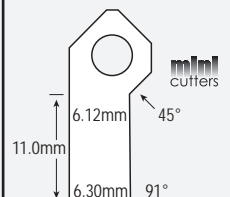

S FT-9020B-HP

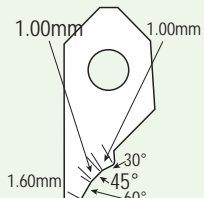

S FTM-185

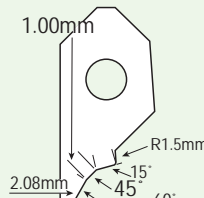

S FTM-187

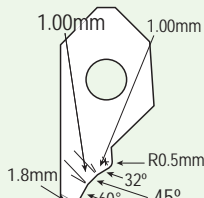

S FTM-188

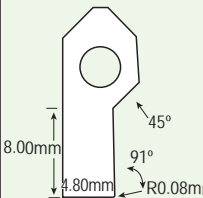

S FTM-190

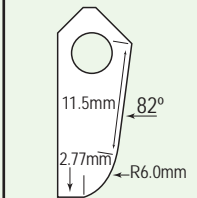

S FTM-82R6B-HP

Micro Blades
Work with holders on pages 7 & 12



3-D Multi-Angle Seat Cutter Blades

SABER TOOTH
SERIES CUTTER BLADES

CYLINDER HEAD
REBUILDING

CLEANING,
ASSEMBLY & SAFETY

SHORT BLOCK
REBUILDING

CRANKSHAFT/
FLYWHEEL GRINDING

MISCELLANEOUS
TOOLS & SUPPLIES

BRAKE SERVICE
TOOLING

MEASURING
TOOLS

V-TWIN & METRIC
HARD PARTS

45° Seat Angle Cutter Blades

30° Seat Angle Cutter Blades

FT-45039U1	FT-45039U2	FT-45039V1	FT-45039W1	FT-45039W2	FT-45039W3
FT-45051V2	FT-45051V4	FT-45051V1	FT-45051V3	FT-45051X1	FT-45055V1
FT-45059V1	FT-45059V2	FT-45059V3	FT-45059X1	FT-45063U1	FT-45063U2
FT-45063V1	FT-45063V3	FT-45063V2	FT-45063W1	FT-45071V1	FT-45075V2
FT-45075V1	FT-45079U1	FT-45079U2	FT-45079V1	FT-45098U1	FT-45098U2
FT-30039T1	FT-30051S1	FT-30059S1	FT-30059S3	FT-30063S1	FT-30071S1
					<p>resharpening available</p> <p>Have Goodson Resharpen Your Valve Seat Cutter Blades</p>
FT-30075S1	FT-30079S1	FT-30079S2	FT-30098S1	FT-30098S2	



**SABER TOOTH
SERIES CUTTER BLADES**

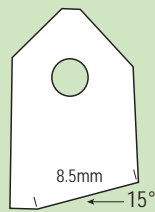

FT-15

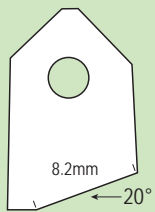

FT-20

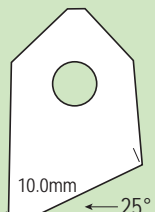

FT-25

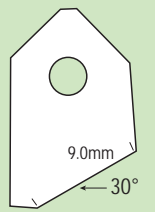

FT-30

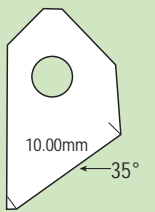

FT-35

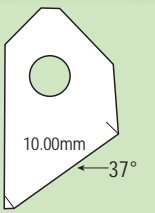

FT-37

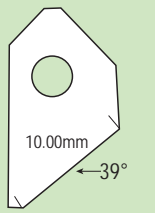

FT-39

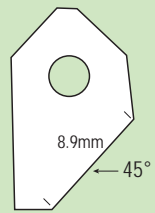

FT-45

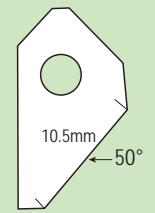

FT-50

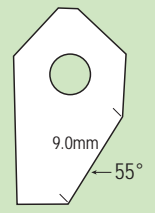

FT-55

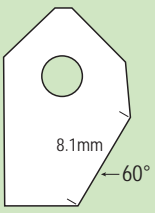

FT-60

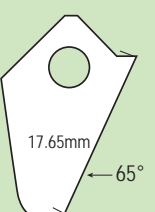

FT-65

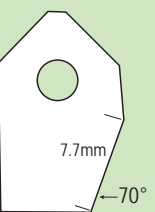

FT-70

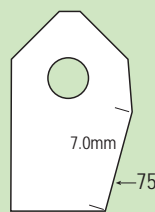

FT-75

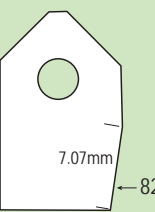

FT-82

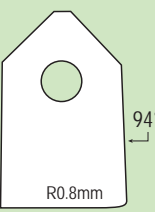

FT-90

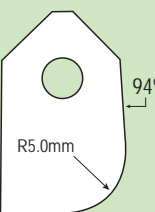

FT-R5

← sized for diesel →

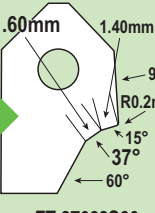

FT-37063S60

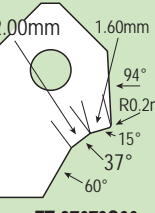

FT-37079S60

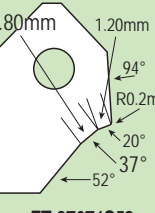

FT-37071S52

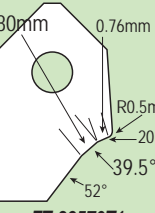

FT-39570T1

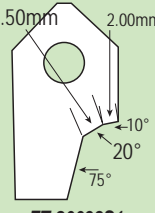

FT-20098S1



- Increase Low Lift Air Flow
- Increase Torque
- Increase Horsepower

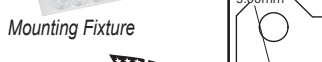

Diesel Relief Tooling

- Use with your seat and guide machine or Bridgeport Mill equipped with a multi-angle seat cutting system
- Developed for Goodson by Joe Mondello Racing Engines
- Use for 6.0L & 7.3L Ford, 12 Valve, 5.9L Cummins & 6.6L Duramax diesel engines
- For 2-Valve & 4-Valve heads • Complete kit includes the Mounting Fixture, .375" Top Offset Pilot, Indexing Pin & Radius Cutter
- This tool is only for use with radius cutters BSS-20CC and BSS-45CC

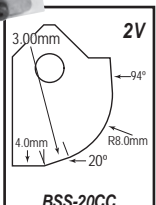

BSS-20CC

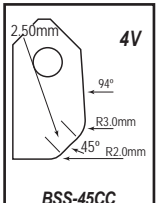

BSS-45CC

Description	Order No.	Incl.
7mm Diesel Relief Tool Kit	DVRT-7MM-KIT	▼
8mm Diesel Relief Tool Kit	DVRT-8MM-KIT	▼
20CC Radius Cutter for 2-Valve Heads	BSS-20CC	x
45CC Radius Cutter for 4-Valve Heads	BSS-45CC	x

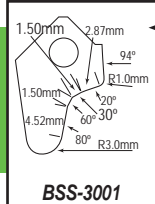

BSS-3001

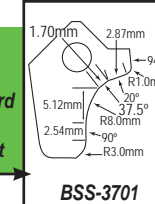

BSS-3701

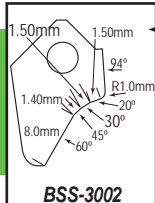

BSS-3002

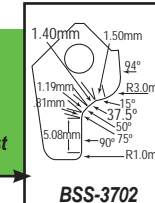

BSS-3702

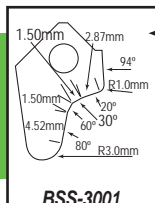

BSS-3001

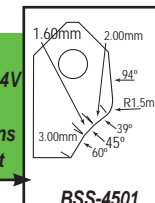

BSS-4501

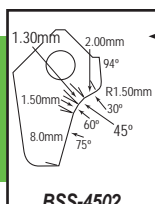

BSS-4502

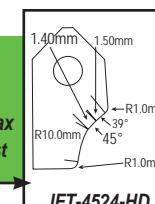

IFT-4524-HD

black smoke series cutters for High Performance Diesel Engines

Developed for Goodson by Joe Mondello Racing Engines. These cutters are designed to be used with your 3-D Fast Cut or other multi-angle tooling.



See How to Use the Diesel Relief Tooling on YouTube! Search for Diesel Valve Relief Tool.

CYLINDER HEAD
REBUILDING

CLEANING,
ASSEMBLY & SAFETY

SHORT BLOCK
REBUILDING

CRANKSHAFT/
FLYWHEEL GRINDING

MISCELLANEOUS
TOOLS & SUPPLIES

BRAKE SERVICE
TOOLING

MEASURING
TOOLS

V-TWIN & METRIC
HARD PARTS

... another satisfied customer

"I appreciate what you guys do and I appreciate you being of service to me for over 30 years. Thanks for all the great products. Looking forward to many more years."
 - Anthony Milano, A N M Auto Machine, Paris, OH, Goodson customer since 1992

CYLINDER HEAD REBUILDING

CLEANING, ASSEMBLY & SAFETY

SHORT BLOCK REBUILDING

CRANKSHAFT/ FLYWHEEL GRINDING

MISCELLANEOUS TOOLS & SUPPLIES

BRAKE SERVICE TOOLING

MEASURING TOOLS

V-TWIN & METRIC HARD PARTS

3-D FAST CUT™ SYSTEM

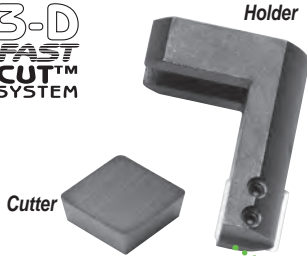

3-D Fast Cut Adjustable Spring Pad Cutters

- No need to change tooling, just change the tool holder and start cutting spring pads
- Works with all popular 3-angle cutting systems
- Square blades are indexable and replaceable
- Tool holder includes one blade



Tool Holders		
Blade Size	Application	Order No.
3/8" / 9.53mm	All except Sunnen®	SPC-375
1/2" / 12.70mm	All except Sunnen®	SPC-500
Replacement Carbide Cutters (for all holder styles above)		
3/8" / 9.53mm		SPCI-375
1/2" / 12.70mm		SPCI-500
Accessories		
Lift Clip for Enhanced Control		3D-CLIP
Valve Spring Seat Cutters on Page 46		



Minnesota Fast Freeze

- Instantly chills seats & guides to -50°F (-45.5°C)
- Creates interference fit with heated aluminum heads
- Finish seat and guide work faster than ever
- Aerosol*
- Use on tight bushings, pins, shafts, etc.
- 10 oz. can

Description	Order No.
Minnesota Fast Freeze	MFF-8

*Hazardous Goods Fees Apply When Shipped by Air

Press Fit Lubricants

- A light coat eases press fit
- Ideal for valve guides, piston pins, cylinder sleeves, etc.
- Eliminates the scoring, gouging and galling of parts during press fitting

Description	Order No.
Goodson Aerosol 6 oz. (170 g)	PFL-200*
Sunnen® Aerosol 7 oz. (198 g)	B-200*
Sunnen® Brush Applicator 200 mL	B-200L*

*Hazardous Goods Fees Apply When Shipped By Air
 Save 10% by buying 6 or more cans of PFL-200



made in America

3-D Fast Cut™ Bowl Profiler

- Machine seats & bowls on a pair of V8 heads in about 40 minutes
- Remove material to contour cylinder head bowl areas and unshroud valves in combustion chambers
- Will not work with Sunnen® Ball Heads

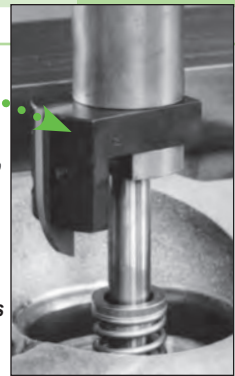

Holder Diameter Range	Order No.
1.25"-1.87" / 32-48mm	NBN-1
1.57"-2.13" / 40-54mm	NBN-2

Blades sold separately

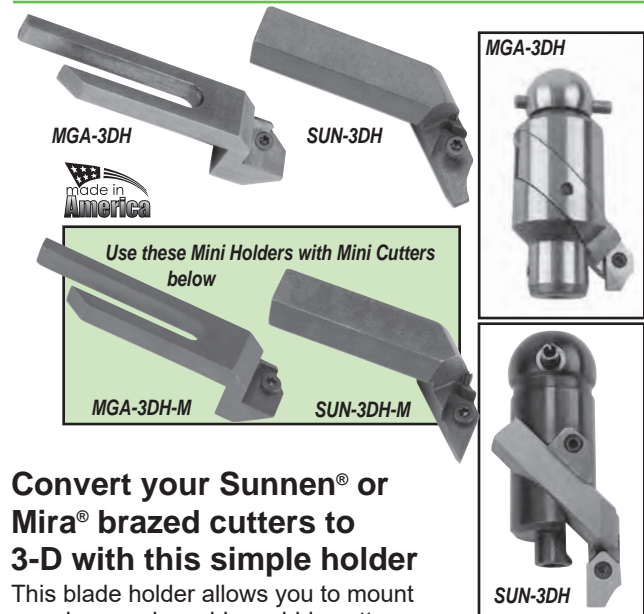
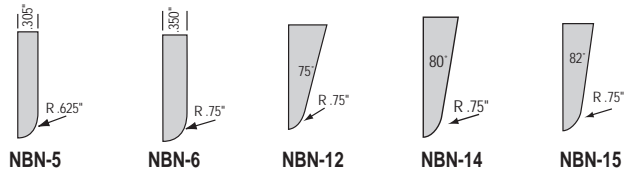

Convert your Sunnen® or Mira® brazed cutters to 3-D with this simple holder

This blade holder allows you to mount premium, replaceable carbide cutters on your existing MIRA® and Sunnen® ball-type tool holders. Choose from our wide selection of replaceable cutters, previously only available for 3-D Fast Cut™ or similar seat cutting systems.

Description	Order No.
Standard Cutter	Mira®
Holder	Sunnen® VSC-Series
Mini Cutter	Mira®
Holder	Sunnen®
Mini Cutters	30°/45°/60°
	32°/45°/60°
view profiles on page 9	30°/45°/60°
	45°/90°
Replacement Screw	

Valve Seat Work

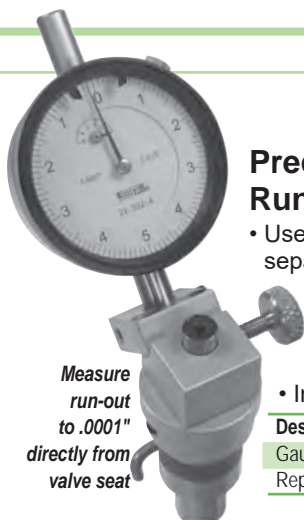

Measure run-out to .0001" directly from valve seat

Precision Valve Seat Run-Out Gauge

- Use with your .375" Top Pilot (sold separately) • Measure run-out to .0001" directly from the seat • Locked to the pilot • Dial indicator remains stationary while rotating contact pointer • .800" - 2.500" dia. range • Includes 2" dia. dial indicator

Description	Order No.
Gauge Assembly	SCG-375
Replacement Indicator	SCG-IND



Valve Seat Machining Aid

- Machine valve seats to a mirror-like finish
- Universal - works with any type of cylinder head machining center
- Use full strength
- Safe for metal surfaces
- Works with mineral-based cutting oils, not water based
- Quart (946mL)
- Order No. **PF-2020**



Layout Fluids

- Choose from blue and red
- Toluene-free • Dries in minutes
- Provides a thin film without cracking or chipping • Prevents glare with a uniform, deep color
- 2 oz. markers feature felt tip applicator
- 4 oz. containers includes brush in cap



Description	Color	Order No.
2 oz. Layout Fluid Markers	Blue	VBF-2
	Red	VRF-2
4 oz. Layout Fluid	Blue	VBF-4
	Red	VRF-4

Spray Bluing Fluid

- Fast drying • Will not rub off
- Good adhesion to all metals and glass
- Non-corrosive • Resists heat
- No flaking or peeling
- Scribes clean lines for precision work
- Eliminates rags, daubers, spilled bottles
- Dries to a smooth level coating
- Aerosol*
- Order No. **SBF-16***



*Hazardous Goods Fees Apply When Shipped by Air

Easy-To-Read Gauge



Premium Valve Seat Run-Out Gauges



- Hardened guide bushings & contact pilot
- Quick thumb screw set-up
- Jeweled bearing indicator reads to $\pm .050"$ with .001" precision
- Range: 1.00"-2.50"
- Measures concentricity

Pilot Size	OAL	Order No.
.375"	5"	VSG-375
.385"	5"	VSG-385
Replacement Indicator		VSG-IND



Valve Seat Scribe Tool

- Tool body fits over .375" Top pilot
- Use valve to set point then scribe seat with inner and outer radii
- We recommend using Layout Fluid so you can see the scribe mark more clearly
- Grind seat top and throat to match face precisely
- Replaces ST-30-BD Scribe Tool
- Order No. **SST-375**

Cutting & Tapping Fluid

- Cut through even the hardest metals
- Spray clings to the surface of the tool to prolong tool life
- Ideal for stainless steel, high nickel alloys, titanium and more
- Use for reaming, seat cutting and CBN cutting
- Aerosol*
- Order No. **CTF-14***



*Hazardous Goods Fees Apply When Shipped by Air
Order 6 or more CTF-14, save 10% off jobber



Prussian Blue Oil Based Paste

- Aids precision fitting of machined surfaces
- Locates high spots on bearings, valves, gears and other close-tolerance components
- Non-drying, easy clean-up
- Coat parts with a uniform film of Prussian Blue; assemble in working position and turn shaft; improper fit will show up as easy-to-see bright blue streaks
- 0.75 fl. oz. tube
- Order No. **PB-75**

CYLINDER HEAD
REBUILDING

CLEANING,
ASSEMBLY & SAFETY

SHORT BLOCK
REBUILDING

CRANKSHAFT/
FLYWHEEL GRINDING

MISCELLANEOUS
TOOLS & SUPPLIES

BRAKE SERVICE
TOOLING

MEASURING
TOOLS

V-TWIN & METRIC
HARD PARTS

Neway Valve Seat Cutting System made in America



CYLINDER HEAD REBUILDING

CLEANING, ASSEMBLY & SAFETY

SHORT BLOCK REBUILDING

CRANKSHAFT/ FLYWHEEL GRINDING

MISCELLANEOUS TOOLS & SUPPLIES

BRAKE SERVICE TOOLING

MEASURING TOOLS

V-TWIN & METRIC HARD PARTS

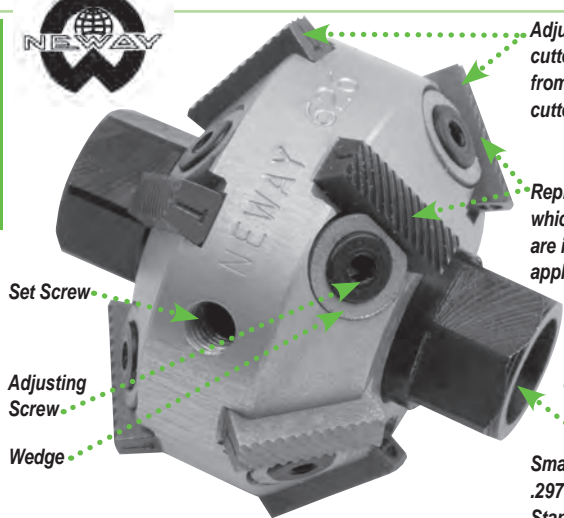

Adjustable Tungsten Carbide cutter blades. Cutters work in a range from 3/8" smaller and 1/4" larger than the cutter body size.

Replaceable cutter blades (see chart for which blades to order for your cutter) are included with body purchase (where applicable).

Cutter body is made of anodized aluminum around a steel hub.

Small Series Cutter Bodies use .297" Top Pilots
Standard Series Cutter Bodies use .375" Top Pilots (pages 3 & 4)

Many cutter body styles available including single angle and double angle for a variety of cutting applications.

special order

Don't see the cutter you need in the chart below? Goodson can order any Neway Cutter Body and tooling available.

Replacement Blades & Parts

Enlarged For Detail

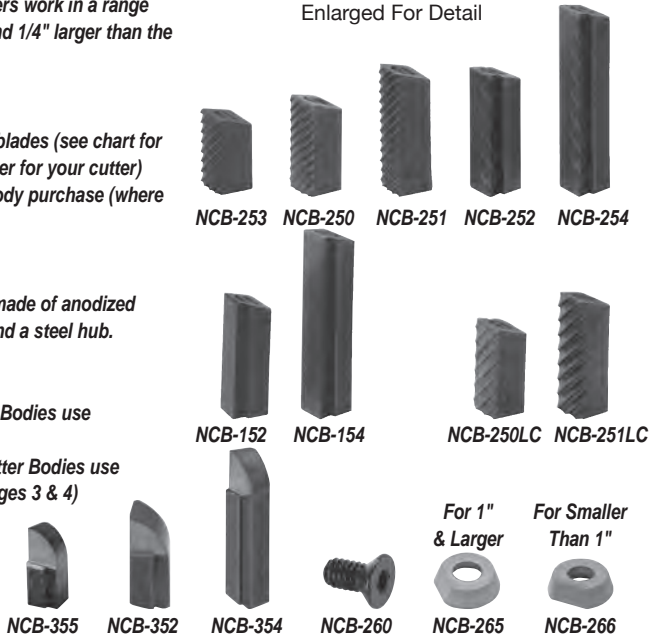

Description				Order No.
Small Series Cutter Bodies (Use .297" Top Pilots - page 3)				
Cutter Body Diameter	Blade Angle	Qty.	Replacement Blade	
0.975" / 24.8mm	45°	3	NCB-253	NCU-122
1.000" / 25.4mm	60°	3	NCB-252	NCU-111
1.312" / 33.3mm	15°/60°	3/3	NCB-251 / 254	NCU-124
Replacement Blades	Angle	Blade Length		
Sold Individually	15-46°	5/16" / 7.9mm	NCB-253	
		3/8" / 9.53mm	NCB-250	
		1/2" / 12.7mm	NCB-251	
60-75°	1/2" / 12.7mm		NCB-252	
		3/4" / 19.05mm	NCB-254	
Non-Serrated	60-75°	1/2" / 12.7mm	NCB-152	
Correction Blades			NCB-154	
Hard Seat Blades	15-46°	3/8" / 9.53mm	NCB-250LC	
		1/2" / 12.7mm	NCB-251LC	
Radius Combustion Chamber Blades		3/8" / 9.53mm	NCB-355	
		1/2" / 12.7mm	NCB-352	
		3/4" / 19.05mm	NCB-354	
Flat Head Screw				NCB-260
Wedge for bodies 1" / 25.4mm and over				NCB-265
Wedge for bodies smaller than 1" / 25.4mm				NCB-266
Tool Kit (includes brush, 2 hex keys and pilot puller)				NKA-246
EZ-Turn Wrench				NTW-EZ
1/2" T-Handle Driver				NTW-505
3/8" T-Handle Driver				NTW-513
Drive Adaptor	1/2" to 3/8"	12.7-9.53mm		NTW-503-1

Description				Order No.
Standard Series Cutter Bodies (Use .375" Top Pilots - page 3 & 4)				
Cutter Body Diameter	Blade Angle	Qty.	Replacement Blade	
1.125" / 28.6mm	30°	3	NCB-250	NCU-278
	45°	3	NCB-250	NCU-268
	60°	3	NCB-252	NCU-269
	37.5°	5	NCB-250	NCU-3731
1.250" / 31.6mm	30°/45°	3/3	NCB-250	NCU-230
	31°/46°	3/3	NCB-250	NCU-203
	60°	3	NCB-252	NCU-270
1.375" / 35.0mm	30°/45°	3/3	NCB-250 / 251	NCU-232
1.500" / 38.0mm	15°/75°	3/3	NCB-251 / 254	NCU-217
	30°/45°	3/3	NCB-251	NCU-234
	30°/45°	5/5	NCB-251	NCU-626
	40°	5	NCB-251	NCU-4038
	60°	3	NCB-254	NCU-205
1.750" / 44.5mm	15°/60°	5/5	NCB-251 / 254	NCU-643
	30°/45°	5/5	NCB-251	NCU-645
	55°	5	NCB-251	NCU-17555
2.000" / 50.8mm	15°/60°	5/5	NCB-251 / 254	NCU-653
	30°/45°	5/5	NCB-261	NCU-660
	60°	5	NCB-254	NCU-657
2.50" / 63.5mm	30°/45°	7/7	NCB-251	NCU-677
	50°	7	NCB-251	NCU-25050
	52°	7	NCB-251	NCU-25052
	55°	7	NCB-251	NCU-25055



T-Handle

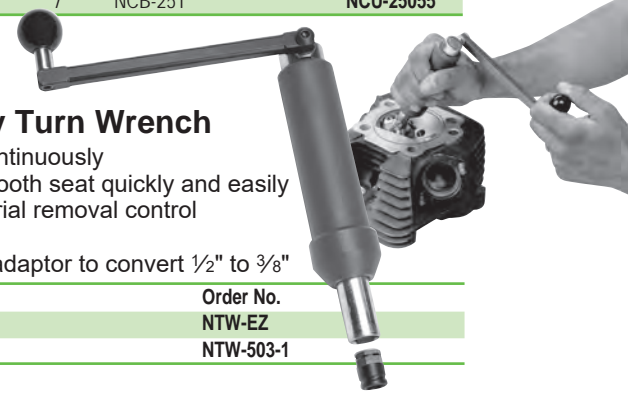

Valve Seat Cutting Fluid

- High silicone content reduces drag on cutters so they last longer
- Promotes smoother cuts
- May be diluted up to 9:1
- Non-aerosol spray



Size	Order No.
16 oz. Spray / 473 mL	SCF-2
1 Gal. / 3.79 L	SCF-10

Neway Easy Turn Wrench

- Turn cutters continuously
- Produces a smooth seat quickly and easily
- Improves material removal control
- Spring loaded
- Includes drive adaptor to convert 1/2" to 3/8"

Description	Order No.
Wrench	NTW-EZ
Drive Adaptor	NTW-503-1

Counterboring Tools

GOODSON Counterbore Cutters CUT TRUE TO SIZE!

Other cutters may cut as much as .005" smaller

tech tips

from the techxperts™

Goodson recommends using
Indexable Counterbore Cutters
at 40 to 60 RPM.



Indexable Counterbore Cutters

These indexable counterbore cutters eliminate down time from having brazed cutters reset or sharpened. You can service them right in your own shop! Each cutter body includes 2 carbide cutter tips with 4 cutting edges. When one edge wears, simply rotate the tip to a new cutting edge. You'll also get a wrench with every cutter body.



DWI-SERIES

- Fits DCM Tech, Sunnen, and Winona Van Norman
- $\frac{9}{16}$ " / 14.3mm arbor

Size	mm	Repl. Insert	Order No.
1.062"	26.97	SCI-250-B	DWI-1062
1.125"	28.57	SCI-250-B	DWI-1125
1.187"	30.15	SCI-250-B	DWI-1187
1.250"	31.75	SCI-250-B	DWI-1250
1.312"	33.32	SCI-250-B	DWI-1312
1.375"	34.93	SCI-250-B	DWI-1375
1.437"	36.50	SCI-250-B	DWI-1437
1/4" Replacement Cutting Insert			SCI-250-B
Replacement Screw for SCI-250-B			SCS-T7
Allen Wrench for SCS-T7			SCW-T7

Size	mm	Repl. Insert	Order No.
1.500"	38.10	SCI-375-B	DWI-1500
1.562"	39.67	SCI-375-B	DWI-1562
1.625"	41.28	SCI-375-B	DWI-1625
1.687"	42.85	SCI-375-B	DWI-1687
1.750"	42.85	SCI-375-B	DWI-1750
1.812"	44.45	SCI-375-B	DWI-1812
1.875"	47.63	SCI-375-B	DWI-1875
1.937"	49.20	SCI-375-B	DWI-1937
2.000"	50.80	SCI-375-B	DWI-2000
2.062"	52.37	SCI-375-B	DWI-2062
2.125"	53.98	SCI-375-B	DWI-2125
3/8" Replacement Cutting Insert			SCI-375-B
Replacement Screw for SCI-375-B			SCS-T15
Torx Wrench for SCS-T15			SCW-T15



SABER TOOTH Cutter Inserts

1.25" Precision Ground
Setting Standard

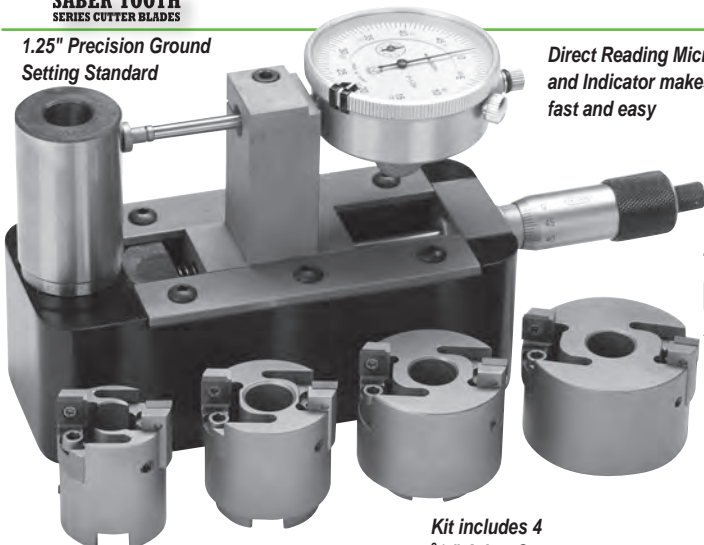

Direct Reading Micrometer
and Indicator makes setting
fast and easy

Kit includes 4
 $\frac{9}{16}$ " Arbor Cutters

GOODSON

Adjustable Counterbore Cutter Kit

- Cutter assemblies feature positive stop adjusting screws to prevent cutters from changing dimensions when in use
- Direct reading micrometer and dial indicator for fast, accurate set-up
- 7 cutter assemblies to choose from, covering a range from 1.25" to 2.75" diameter
- Kit substitutions are available, call to inquire
- Heavy duty billet steel construction

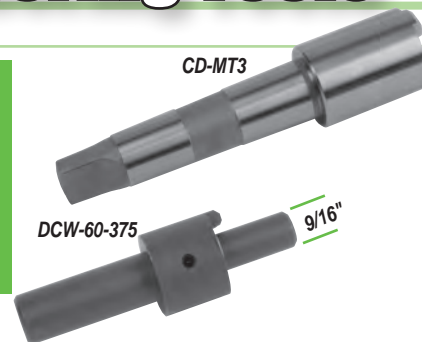

Counterbore Cutter Drive Adaptors

Cutter Drivers	Order No.
#3 MT Driver	CD-MT3
Fits .750" Bridgeport Collet	
$\frac{9}{16}$ " arbor, .375" pilot	DCW-60-375
$\frac{9}{16}$ " arbor, .385" pilot	DCW-60-385

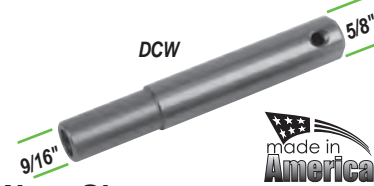

Wear Sleeves for DWA & DWI Counter Bore Cutters

- Wear sleeves fit CD-MT3 Driver

Pilot Top Size	Order No.
.375" (9.53mm)	DCW-375
.385" (9.78mm)	DCW-385



SABER TOOTH
SERIES CUTTER BLADES



Scan with your smart
phone or other device
to view



Description	Order No.	Incl.
Complete Kit ($\frac{9}{16}$ " / 14.3mm Arbor)	DWA-300	
Cutter Assemblies (in/mm) complete with cutting inserts installed		
$\frac{9}{16}$ " Arbor 1.250"-1.375" / 31.8-34.9	DWA-250	x
1.375"-1.500" / 34.9-38.1	DWA-375	x
1.500"-1.750" / 38.1-44.5	DWA-302	x
1.750"-2.000" / 44.5-50.8	DWA-303	x
2.000"-2.250" / 50.8-57.2	DWA-304	
2.250"-2.500" / 57.2-63.5	DWA-305	
2.500"-2.750" / 63.5-69.9	DWA-306	
Replacement Cutting Insert	DKB-7	
Replacement Insert Screw	DKS-7	
Wrench	FT-WRENCH	x
Hex Keys $\frac{5}{32}$ "	DWA-5/32	x
$\frac{5}{64}$ "	DWA-5/64	x
$\frac{9}{64}$ "	DWA-5/32	x
Wear Sleeves (see note below)		
For .375" Top Pilot	DCW-375	
For .385" Top Pilot	DCW-385	

To use the Counterbore Cutter Kit with Kwik-Way & Peterson Machines you will need to adapt the $\frac{9}{16}$ " cutter to fit the $\frac{5}{8}$ " drive. Use a DCW wear sleeve.

CYLINDER HEAD
REBUILDING

CLEANING,
ASSEMBLY & SAFETY

SHORT BLOCK
REBUILDING

FLYWHEEL GRINDING
CRANKSHAFT/

TOOLS & SUPPLIES
MISCELLANEOUS

TOOLING
BRAKE SERVICE

MEASURING
TOOLS

V-TWIN & METRIC
HARD PARTS

full service
...fast



"At Goodson, we're trained to know your business. Regular training sessions are held for our entire staff to help us better understand your work so we can provide you with the best possible service."

- Anne, Goodson Accounting - 20 years of service

CYLINDER HEAD
REBUILDING

CLEANING,
ASSEMBLY & SAFETY

CRANK
LOCK
DRIVE
FLYWHEEL
REBUILDING

CRANK
LOCK
DRIVE
FLYWHEEL
REBUILDING

MISCELLANEOUS
TOOLS & SUPPLIES

TOOLING
BRAKE SERVICE

MEASURING
TOOLS
V-TWIN & METRIC
HARD PARTS

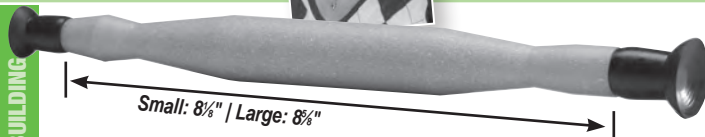

Traditional Valve Lapping Sticks

- Oil resistant polyethylene handles
- Locking tabs eliminate cup slippage

Description	Cup ID	Order No.
Small Lapping Stick	8 1/2" Long	VLS-15
Replacement Cups	15.9mm / 0.625" dia. .156"	VLS-5/8
	20.6mm / 0.813" dia. .230"	VLS-13/16
Large Lapping Stick	8 3/4" Long	VLS-30
Replacement Cups	28.6mm / 1.125" dia. .380"	VLS-1 1/8
	34.9mm / 1.375" dia. .380"	VLS-1 3/8

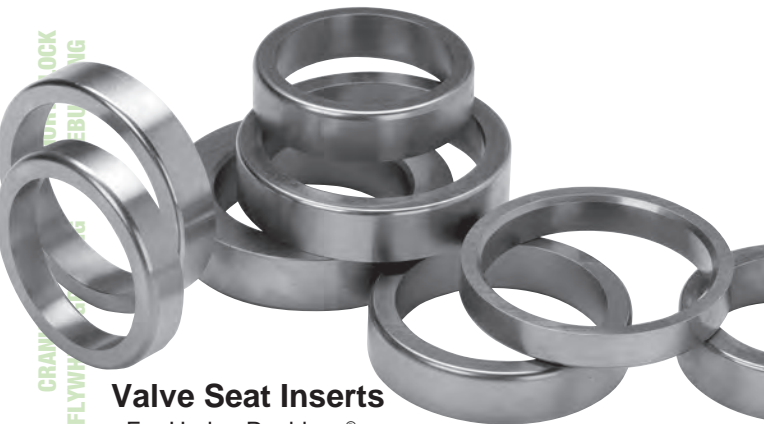

Valve Seat Inserts

- For Harley-Davidson®
- Easy to machine
- Effectively dissipate heat for consistent valve sealing
- Hardness increases during engine break-in
- Radiused for easy installation



Replacement Valve Seats For Shovel Head 1200 & 1340

Application	OD	ID	Thick	Order No.	Supersedes
Exhaust	1.944"	1.575"	.400"	10-HC493	HVS-1944
Intake	2.135"	1.750"	.400"	10-HC542	HVS-2135

Oversize Seats For Shovel, Evolution, Twin Cam & M8 - machining required

	OD	ID	Thick	Order No.	Supersedes
Fits M8	1.630"	1.180"	.385"	10-HC414	HVS-1630
	1.757"	1.410"	.430"	10-HC447	HVS-1757
	1.882"	1.520"	.410"	10-HC478	HVS-1882
	2.008"	1.610"	.440"	10-HC510	HVS-2008
	2.040"	1.700"	.425"	10-HC518	HVS-2040
	2.070"	1.610"	.460"	10-HC526	HVS-2070
	2.132"	1.800"	.460"	10-HC541	HVS-2132
	2.163"	1.750"	.455"	10-HC549	HVS-2163

For Iron Head Sportster

Application	OD	ID	Thick	Order No.	Supersedes
Exhaust	1.757"	1.371"	.315"	10-HC446	HVS-1757S
Intake	2.068"	1.750"	.315"	10-HC525	HVS-2068

Universal Repair Seat

	OD	ID	Thick	Order No.	Supersedes
Powdered	1.339"	1.024"	.375"	10-SC340	MVS-42
Metal	1.693"	1.299"	.434"	10-SC430	MVS-58
	1.819"	1.375"	.450"	10-HC462	HVS-1820
	1.945"	1.500"	.450"	10-HC494	HVS-1945
	2.257"	1.870"	.450"	10-HC573	HVS-2257

tech tips When installing seats preheat head to 400° and freeze the seat for easier installation. Press fit .006" to .008".

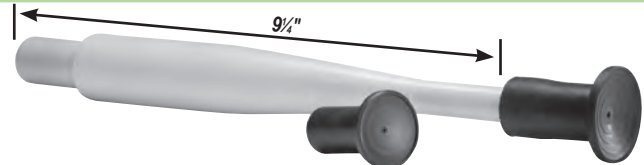

Vacuum Style Lapping Stick

- Press the spring-loaded vacuum pump for a firm hold - stays on until you release the vacuum
- Includes 3 cup sizes (also sold separately)

Description	Cup ID	Order No.
Vacuum Lapping Stick	9 1/2" Long	VLV-50
Replacement Cups	19.1mm / 0.750" dia. .415"	VLV-3/4
	25.4mm / 1.000" dia. .415"	VLV-1
	31.8mm / 1.250" dia. .415"	VLV-1 1/4

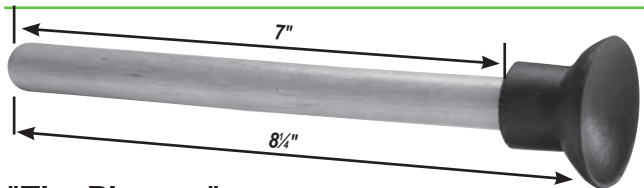

"The Plunger" Hand Valve Lapping Stick

- Large diameter for sure grip
- For 2" and larger valves



Description	Cup ID	Order No.
Hand Valve Lapping Stick	8 1/2" Long	VLS-75
Replacement Cup	44.5mm / 1.750" dia. .313"	VLS-1 3/4

Nickel-Chrome Valve Seats



WARNING: This product can expose you to chemicals, including Nickel which are known to the state of California to cause cancer

OD	ID	Depth	Order No.	OD	ID	Depth	Order No.
1.250"	0.812"	1/4"	VS-1250	1.625"	1.375"	1/32"	VS-1625A
1.312"	1.000"	1/4"	VS-1312	1.687"	1.375"	1/4"	VS-1687
1.375"	1.062"	1/4"	VS-1375	1.750"	1.500"	1/4"	VS-1750
1.437"	1.125"	1/4"	VS-1437	1.812"	1.500"	1/4"	VS-1812
1.500"	1.187"	1/4"	VS-1500	1.875"	1.562"	1/4"	VS-1875
1.562"	1.250"	1/4"	VS-1562	1.937"	1.625"	1/4"	VS-1937
1.562"	1.312"	1/32"	VS-1562A	2.000"	1.625"	1/4"	VS-2000
1.625"	1.312"	1/4"	VS-1625				

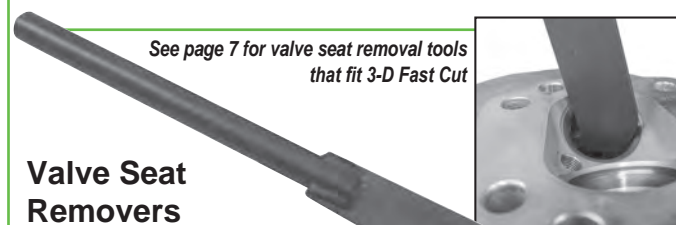

See page 7 for valve seat removal tools that fit 3-D Fast Cut

Valve Seat Removers

- Use to pry out valve seat inserts or stubborn grease seals
- Choose from 90°, 100° and 120°, or buy the set
- **Not** recommended for use on aluminum heads
- Set includes one of each angle
- 13 7/8" overall length

Description	Order No.
3-Pc. Set	VSP-SET ▼
90°	VSP-90 x
100°	VSP-100 x
120°	VSP-120 x



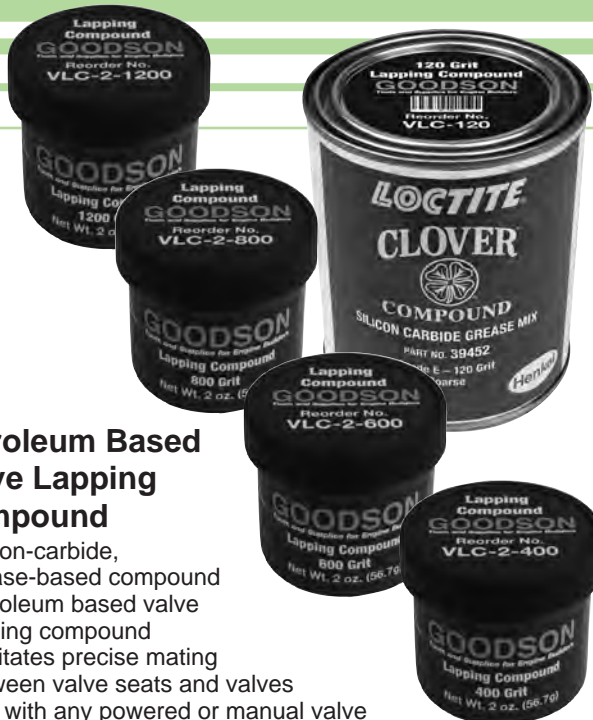

Petroleum Based Valve Lapping Compound

- Silicon-carbide, grease-based compound
- Petroleum based valve lapping compound facilitates precise mating between valve seats and valves
- Use with any powered or manual valve lapping tools • The higher the number the finer the grit

Size	Grit	Order No.
2 oz. / 56.7g	400 Grit	VLC-2-400
	600 Grit	VLC-2-600
	800 Grit	VLC-2-800
	1200 Grit	VLC-2-1200
2 oz. / 56.7g ea. Combo	120 Grit & 280 Grit	VLC-4
1 lb. / 453.6g	120 Grit	VLC-120
	180 Grit	VLC-180
	280 Grit	VLC-280



VSD-HD

Valve Seat Drivers For Fast Seat Installation

- Pneumatic Drivers install seats faster, easier and without galling • Driver Head ID is .75" / 19.05mm

Description	Order No.
Manual Drivers	
.375" / 9.53mm & .385" / 9.78mm ID	VSD-202-G
Driver Heads (Blackened for Rust Resistance)	
1.000" to 1.125" Seats / 25.4 - 28.6mm	VSD-203-G
1.250" to 1.375" Seats / 31.8 - 34.9mm	VSD-204-G
1.500" to 1.625" Seats / 38.1 - 41.3mm	VSD-205-G
1.750" to 1.875" Seats / 44.5 - 47.6mm	VSD-206-G
2.000" to 2.125" Seats / 50.8 - 54.0mm	VSD-207-G
Driver Heads (Not Blackened)	
1.750" to 2.000" Seats / 44.5 - 50.8mm	VSD-HD
Pneumatic Drivers	
.375" / 9.53mm & .385" / 9.78mm ID	PSD-385
.437" / 11.10mm ID	PSD-437

Watch an overview of Valve Lapping Tools including live demonstrations in our Tech Lab Tuesday Video Library. Scan the code below with your smart phone or other device for instant access.



Air Powered Valve Lapping Tool

- Operates on 90psi
- Includes air tool and 3 replacement cups • Air actuated ... no electricity needed • Cups also sold separately
- Air supply pressure: 89 psi
- Sound pressure: 77dB
- Sound power: 88 dB
- Hand/arm weighted vibration: 5.43 m/s²
- Use a light touch when operating - no pressure required!



Replacement Cups Also Available

Description	Cup ID	Order No.
Air Powered Valve Lapping Tool		AVLP-300
Replacement Cups	21mm / 0.827" dia. .230"	AVLP-301
	33mm / 1.299" dia. .380"	AVLP-302
	38mm / 1.496" dia. .380"	AVLP-303

Powered Lapping Tool

- Change rotary action into an effective oscillating motion
- Drive with a power drill
- Makes lapping faster and easier
- Includes 2 cup sizes



Description	Cup ID	Order No.
Complete Tool		VLP-100
Replacement Cups	22.2mm / 0.875" dia. .460"	VLP-10
	25.4mm / 1.000" dia. .460"	VLP-20



Minnesota Fast Freeze

- Instantly chills seats & guides to -50°F (-45.5°C) • Creates interference fit with heated aluminum heads • Finish seat and guide work faster than ever • 10 oz. Aerosol*
- Use on tight bushings, pins, shafts, etc.
- Order No. MFF-8*

*Hazardous Goods Fees Apply When Shipped by Air

CYLINDER HEAD REBUILDING
CLEANING, ASSEMBLY & SAFETY
SHORT BLOCK REBUILDING
CRANKSHAFT/ FLYWHEEL GRINDING
MISCELLANEOUS TOOLS & SUPPLIES
BRAKE SERVICE TOOLING
MEASURING TOOLS
V-TWIN & METRIC HARD PARTS

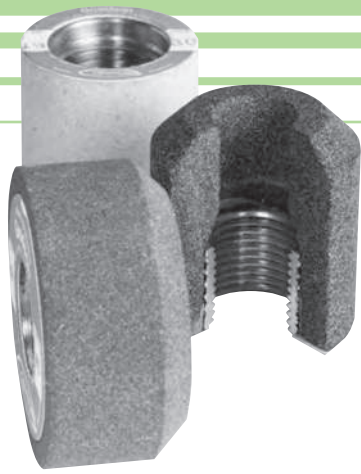

Goodson seat wheels are built to grind accurately & outlast the competition

- Brass bushings resist galling or seizing to the holder
- Heat-cured, permanent epoxy bonding prevents loose bushings
- Bushings are set deep to expose the most abrasive for long life
- Each wheel is trued and checked to assure accurate, vibration-free grinding
- **Custom sizes and angles are available in-house – Call for more information**

**GP**

General Purpose
Removes material from cast-iron seats or inserts.

CB

Cool Blue
Pure Aluminum-Oxide stone. Superior general purpose stone for high performance Beryllium seats. Very sharp.

S

Stellite
Specially formulated to grind Stellite and other types of hardened seat.

F

Finish
Final polishing stone gives an ideal final finish with minimal stock removal. Removes chatter marks.

NC

Nickel Chrome
For aluminum heads with chrom-alloy seat inserts. Soft abrasive stone to grind hard seats. Speckled.

R

Ruby
The original Black & Decker composition, general purpose stone.

KW

Fits Kwik-Way 13/16"x13 thread

Colors may vary due to manufacturing processes

Size Inch mm	General Purpose (GP) 90 Grit			Cool Blue (CB) 80 Grit		Stellite (S) 90 Grit	
	00°	30°	45°	00°	45°	00°	45°
1 1/4" 32	KW-1000-GP	KW-1030-GP	KW-1045-GP	KW-1000-CB	KW-1045-CB	KW-1000-S	KW-1045-S
1 1/16" 33	KW-1000A-GP	-----	KW-1045A-GP	KW-1000A-CB	KW-1045A-CB	-----	-----
1 3/8" 35	KW-1100-GP	KW-1130-GP	KW-1145-GP	KW-1100-CB	KW-1145-CB	KW-1100-S	KW-1145-S
1 1/8" 36	KW-1100A-GP	-----	KW-1145A-GP	KW-1100A-CB	KW-1145A-CB	KW-1100A-S	KW-1145A-S
1 1/2" 38	KW-1200-GP	KW-1230-GP	KW-1245-GP	KW-1200-CB	KW-1245-CB	KW-1200-S	KW-1245-S
1 1/16" 39	KW-1200A-GP	-----	KW-1245A-GP	-----	KW-1245A-CB	KW-1200A-S	KW-1245A-S
1 5/8" 41	KW-1300-GP	KW-1330-GP	KW-1345-GP	KW-1300-CB	KW-1345-CB	KW-1300-S	KW-1345-S
1 1/16" 43	KW-1300A-GP	-----	KW-1345A-GP	KW-1300A-CB	KW-1345A-CB	KW-1300A-S	KW-1345A-S
1 3/4" 44	KW-1400-GP	KW-1430-GP	KW-1445-GP	KW-1400-CB	KW-1445-CB	KW-1400-S	KW-1445-S
1 7/8" 47	KW-1500-GP	KW-1530-GP	KW-1545-GP	KW-1500-CB	KW-1545-CB	KW-1500-S	KW-1545-S
2" 51	KW-1600-GP	KW-1630-GP	KW-1645-GP	KW-1600-CB	KW-1645-CB	KW-1600-S	KW-1645-S
2 1/8" 54	KW-1700-GP	KW-1730-GP	KW-1745-GP	KW-1700-CB	KW-1745-CB	KW-1700-S	KW-1745-S
2 1/4" 57	KW-1800-GP	KW-1830-GP	KW-1845-GP	KW-1800-CB	KW-1845-CB	KW-1800-S	KW-1845-S
2 3/8" 60	KW-1900-GP	KW-1930-GP	KW-1945-GP	KW-1900-CB	KW-1945-CB	-----	-----
Size Inch mm	Finishing (F) 150 Grit		Nickel Chrome (NC) 60 Grit		Ruby (R) 80 Grit		
	30°	45°	00°	45°	00°	45°	
1 1/4" 32	-----	KW-1045-F	KW-1000-NC	KW-1045-NC	KW-1000-R	KW-1045-R	
1 3/8" 35	-----	KW-1145-F	KW-1100-NC	KW-1145-NC	KW-1100-R	KW-1145-R	
1 1/16" 36	-----	KW-1145A-F	KW-1100A-NC	KW-1145A-NC	-----	-----	
1 1/2" 38	-----	KW-1245-F	KW-1200-NC	KW-1245-NC	KW-1200-R	KW-1245-R	
1 1/16" 39	-----	KW-1245A-F	KW-1200A-NC	KW-1245A-NC	-----	-----	
1 5/8" 41	-----	KW-1345-F	KW-1300-NC	KW-1345-NC	KW-1300-R	KW-1345-R	
1 1/16" 43	-----	KW-1345A-F	KW-1300A-NC	KW-1345A-NC	-----	-----	
1 3/4" 44	-----	KW-1445-F	KW-1400-NC	KW-1445-NC	KW-1400-R	KW-1445-R	
1 7/8" 47	-----	KW-1545-F	KW-1500-NC	KW-1545-NC	KW-1500-R	KW-1545-R	
2" 51	-----	KW-1645-F	KW-1600-NC	KW-1645-NC	KW-1600-R	KW-1645-R	
2 1/8" 54	-----	KW-1745-F	KW-1700-NC	KW-1745-NC	-----	-----	
2 1/4" 57	-----	KW-1845-F	KW-1800-NC	KW-1845-NC	-----	-----	
2 3/8" 60	-----	-----	KW-1900-NC	KW-1945-NC	-----	-----	

Ordering is easy!

- 1 - Find the diameter (valve head diameter + 1/16" to 1/8").
- 2 - Find the angle you need (you can modify angles with our Valve Seat Wheel Dresser Stand, page 24).
- 3- Select the abrasive to match your job.

tech tips
from the techxperts™

Keep your stones grinding at their best with a
Seat Wheel Dresser Stand!

See Page 24 for details



Hex Drive Seat Grinding Kit includes everything listed below. Everything comes packed in a handy storage case.

Valve Seat Grinding Sets

Order the set as-is or modify a set to meet your specific needs. Set contents include:

Description	OE Number	Order No.	Includes
45° Hex Drive Motor Seat Grinding Set (110V, 50/60 Hz)		SGH-110-KIT	▼
45° Hex Drive Motor Seat Grinding Set (220V, 50/60Hz)		SGH-220-KIT	▼
Hex Drive Seat Grinder - 45° 110V, 50/60Hz	031-3100-20	031-3100-20	1
Hex Drive Seat Grinder - 45° 220V, 50/60Hz	031-3100-27	031-3100-27	1
Universal Valve Seat Wheel Dresser w/G-13P Diamond	-----	SWD-UNI	1 1
Replacement Dressing Stand Diamond	-----	G-13P	
Dressing Stand Pilot with .437" Top	031-1102-89	031-1102-89	1 1
Stone Holder - 13/16" x 13 Thread w/Plunger	031-0300-30	031-0300-30	2 2
Heavy Duty Plastic Case (21 ⁵ / ₁₆ " x 12 ¹ / ₂ " x 13 ¹ / ₂ ")	001-1000-25	SG-CASE	1 1
Seat Stone Removal Tool	-----	KW-SRT	1 1
Leather Vibration Reducer (3 Pc.)	-----	KHW-3	1 1
.437" Top Pilots Dia./mm			
.2755" / 7.00mm	030-0237-30	P-5275K	1 1
.2763" / 7.02mm	030-0237-49	P-5276K	1 1
.2765" / 7.05mm	030-0237-40	P-5277K	1 1
.3125" / 7.93mm	030-0239-35	P-5312K	1 1
.3135" / 7.96mm	030-0239-51	P-5313K	1 1
.3145" / 7.98mm	030-0239-78	P-5314K	1 1
.3150" / 8.00mm	030-0239-94	P-5315K	1 1
.3437" / 8.72mm	030-0242-73	P-5343K	1 1
.3440" / 8.74mm	030-0243-03	P-5344K	1 1
.3457" / 8.78mm	030-0243-11	P-5345K	1 1
.3730" / 9.47mm	030-0247-45	P-5373K	1 1
.3750" / 9.52mm	030-0247-70	P-5375K	1 1
General Purpose Valve Seat Grinding Stones (3/16"x13)	30°		45°
1.375" / 35mm	KW-1130-GP	KW-1145-GP	1 1
1.500" / 38mm	KW-1230-GP	KW-1245-GP	1 1
1.615" / 41mm	KW-1330-GP	KW-1345-GP	1 1
1.750" / 44mm	KW-1430-GP	KW-1445-GP	1 1
1.785" / 47mm	KW-1530-GP	KW-1545-GP	1 1
2.000" / 51mm	KW-1630-GP	KW-1645-GP	1 1
2.125" / 54mm	KW-1730-GP	KW-1745-GP	1 1
Finishing Valve Seat Grinding Stones (3/16"x13)	30°		45°
1.375" / 35mm	KW-1130-F	KW-1145-F	1 1
1.500" / 38mm	KW-1230-F	KW-1245-F	1 1
1.625" / 41mm	KW-1330-F	KW-1345-F	1 1
1.750" / 44mm	KW-1430-F	KW-1445-F	1 1
1.785" / 47mm	KW-1530-F	KW-1545-F	1 1
2.000" / 51mm	KW-1630-F	KW-1645-F	1 1
2.125" / 54mm	KW-1730-F	KW-1745-F	1 1

made in America
KWIK-WAY
 Seat Grinding Equipment & Supplies
GOODSON
 Tools and Supplies for Engine Builders



45° Kwik-Way Hex Drive (SGH) Electric Motor Unit 1/2"-20 Thread

- Heavy duty electric motor
- 11,500 RPM • Weighs 9 lbs.
- 3/5 HP, 7.5 Amps

Description	Order No.
110V, 50/60Hz	031-3100-20
220V, 50/60Hz	031-3100-27
Nose Assembly	031-3105-12
Hex Drive Assembly	031-3112-17
Replacement Leather Pad	031-1009-41
2 Pc. Brush Set	003-0072-43
Trigger Switch	000-1201-20

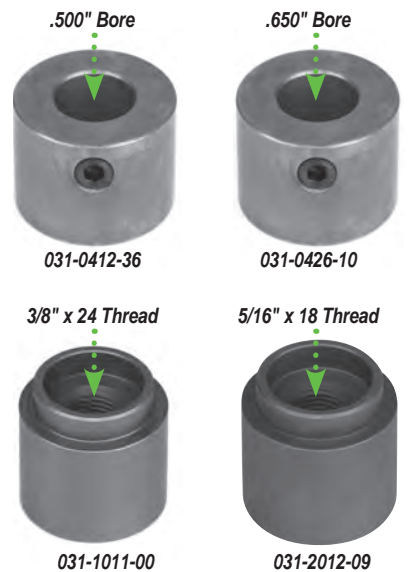

Hex Drive Replacement Adaptors

- Adapt your Seat Grinder Motor to fit various Kwik-Way Seat Grinders

Description	Order No.
.500" Bore	031-0412-36
Fit SGA Motor Units with Serial No. 0 to 2000	
.650" Bore	031-0426-10
Fit SGA Motor Units with Serial No. 4000 & up	
3/8" x 24 Thread	031-1011-00
Fit SGAll Hex Motor Units	
5/16" x 18" Thread	031-2012-09
Fit SSG Hex Motor Units	

CYLINDER HEAD REBUILDING
 CLEANING, ASSEMBLY & SAFETY
 SHORT BLOCK REBUILDING
 FLYWHEEL GRINDING
 CRANKSHAFT/ MISCELLANEOUS TOOLS & SUPPLIES
 BRAKE SERVICE TOOLING
 MEASURING TOOLS
 V-TWIN & METRIC HARD PARTS



"If you need a custom angle or size in a Valve Seat Stone, Goodson can do it. We grind seat stones in-house to standard and custom dimensions. Give Goodson a call today."
- Tim, Goodson Production - 9 years of service



CYLINDER HEAD
REBUILDING

CLEANING,
ASSEMBLY & SAFETY

SHORT BLOCK
REBUILDING

CRANKSHAFT/
FLYWHEEL GRINDING

MISCELLANEOUS
TOOLS & SUPPLIES

BRAKE SERVICE
TOOLING

MEASURING
TOOLS

V-TWIN & METRIC
HARD PARTS

SX

Fits Sioux™, KO Lee, US, Thor, Skil, Winona 11/16"x16 thread
Colors may vary due to manufacturing processes

Size Inch mm	General Purpose (GP) 70 Grit				Cool Blue (CB) 80 Grit		Ruby 80 Grit		
	00°	30°	45°	60°	00°	45°	00°	45°	
7/8" 22							SX-500-R	SX-545-R	
15/16" 24							SX-600-R	SX-645-R	
1" 25							SX-700-R	SX-745-R	
1 1/16" 27							SX-800-R	SX-845-R	
1 1/8" 28	SX-900-GP	SX-930-GP	SX-945-GP				SX-900-R	SX-945-R	
1 3/16" 30	SX-900A-GP		SX-945A-GP						
1 1/4" 32	SX-1000-GP	SX-1030-GP	SX-1045-GP	SX-1060-GP	SX-1000-CB	SX-1045-CB	SX-1000-R	SX-1045-R	
1 5/16" 33	SX-1000A-GP		SX-1045A-GP		SX-1000A-CB	SX-1045A-CB			
1 3/8" 35	SX-1100-GP	SX-1130-GP	SX-1145-GP	SX-1160-GP	SX-1100-CB	SX-1145-CB	SX-1100-R	SX-1145-R	
1 1/2" 36	SX-1100A-GP		SX-1145A-GP		SX-1100A-CB	SX-1145A-CB			
1 1/2" 38	SX-1200-GP	SX-1230-GP	SX-1245-GP	SX-1260-GP	SX-1200-CB	SX-1245-CB	SX-1200-R	SX-1245-R	
1 5/8" 39	SX-1200A-GP		SX-1245A-GP		SX-1200A-CB	SX-1245A-CB			
1 7/8" 41	SX-1300-GP	SX-1330-GP	SX-1345-GP	SX-1360-GP	SX-1300-CB	SX-1345-CB	SX-1300-R	SX-1345-R	
1 11/16" 43	SX-1300A-GP		SX-1345A-GP		SX-1300A-CB	SX-1345A-CB			
1 3/4" 44	SX-1400-GP	SX-1430-GP	SX-1445-GP	SX-1460-GP	SX-1400-CB	SX-1445-CB	SX-1400-R	SX-1445-R	
1 7/8" 47	SX-1500-GP	SX-1530-GP	SX-1545-GP	SX-1560-GP	SX-1500-CB	SX-1545-CB	SX-1500-R	SX-1545-R	
2" 51	SX-1600-GP	SX-1630-GP	SX-1645-GP	SX-1660-GP	SX-1600-CB	SX-1645-CB	SX-1600-R	SX-1645-R	
2 1/8" 54	SX-1700-GP	SX-1730-GP	SX-1745-GP		SX-1700-CB	SX-1745-CB	SX-1700-R	SX-1745-R	
2 1/4" 57	SX-1800-GP	SX-1830-GP	SX-1845-GP	SX-1860-GP	SX-1800-CB	SX-1845-CB	SX-1800-R	SX-1845-R	
2 3/8" 60	SX-1900-GP	SX-1930-GP	SX-1945-GP	SX-1960-GP	SX-1900-CB	SX-1945-CB	SX-1900-R	SX-1945-R	
2 1/2" 63	SX-2000-GP	SX-2030-GP	SX-2045-GP		SX-2000-CB	SX-2045-CB	SX-2000-R	SX-2045-R	
2 5/8" 66	SX-2100-GP	SX-2130-GP	SX-2145-GP		SX-2100-CB	SX-2145-CB			
Size Inch mm	Stellite (S) 100 Grit			Finishing (F) 150 Grit			Nickel Chrome 60 Grit		
	00°	30°	45°	00°	30°	45°	00°	30°	45°
7/8" 22				SX-500-F		SX-545-F	SX-500-NC		SX-545-NC
15/16" 24				SX-600-F		SX-645-F	SX-600-NC		SX-645-NC
1" 25				SX-700-F		SX-745-F	SX-700-NC		SX-745-NC
1 1/16" 27				SX-800-F		SX-845-F	SX-800-NC		SX-845-NC
1 1/8" 28	SX-900-S	SX-930-S	SX-945-S	SX-900-F	SX-930-F	SX-945-F	SX-900-NC	SX-930-NC	SX-945-NC
1 3/16" 30	SX-900A-S		SX-945A-S	SX-900A-F		SX-945A-F	SX-900A-NC		SX-945A-NC
1 1/4" 32	SX-1000-S	SX-1030-S	SX-1045-S	SX-1000-F	SX-1030-F	SX-1045-F	SX-1000-NC	SX-1030-NC	SX-1045-NC
1 5/16" 33	SX-1000A-S		SX-1045A-S	SX-1000A-F		SX-1045A-F	SX-1000A-NC		SX-1045A-NC
1 3/8" 35	SX-1100-S	SX-1130-S	SX-1145-S	SX-1100-F	SX-1130-F	SX-1145-F	SX-1100-NC	SX-1130-NC	SX-1145-NC
1 1/2" 36	SX-1100A-S		SX-1145A-S	SX-1100A-F		SX-1145A-F	SX-1100A-NC		SX-1145A-NC
1 1/2" 38	SX-1200-S	SX-1230-S	SX-1245-S	SX-1200-F	SX-1230-F	SX-1245-F	SX-1200-NC	SX-1230-NC	SX-1245-NC
1 5/8" 39	SX-1200A-S		SX-1245A-S	SX-1200A-F		SX-1245A-F	SX-1200A-NC		SX-1245A-NC
1 7/8" 41	SX-1300-S	SX-1330-S	SX-1345-S	SX-1300-F	SX-1330-F	SX-1345-F	SX-1300-NC	SX-1330-NC	SX-1345-NC
1 11/16" 43	SX-1300A-S		SX-1345A-S	SX-1300A-F		SX-1345A-F	SX-1300A-NC		SX-1345A-NC
1 3/4" 44	SX-1400-S	SX-1430-S	SX-1445-S	SX-1400-F	SX-1430-F	SX-1445-F	SX-1400-NC	SX-1430-NC	SX-1445-NC
1 7/8" 47	SX-1500-S	SX-1530-S	SX-1545-S	SX-1500-F	SX-1530-F	SX-1545-F	SX-1500-NC	SX-1530-NC	SX-1545-NC
2" 51	SX-1600-S	SX-1630-S	SX-1645-S	SX-1600-F	SX-1630-F	SX-1645-F	SX-1600-NC	SX-1630-NC	SX-1645-NC
2 1/8" 54	SX-1700-S	SX-1730-S	SX-1745-S	SX-1700-F	SX-1730-F	SX-1745-F	SX-1700-NC	SX-1730-NC	SX-1745-NC
2 1/4" 57	SX-1800-S	SX-1830-S	SX-1845-S	SX-1800-F	SX-1830-F	SX-1845-F	SX-1800-NC	SX-1830-NC	SX-1845-NC
2 3/8" 60	SX-1900-S	SX-1930-S	SX-1945-S	SX-1900-F	SX-1930-F	SX-1945-F	SX-1900-NC	SX-1930-NC	SX-1945-NC
2 1/2" 63	SX-2000-S	SX-2030-S	SX-2045-S	SX-2000-F	SX-2030-F	SX-2045-F	SX-2000-NC	SX-2030-NC	SX-2045-NC
2 5/8" 66							SX-2100-NC	SX-2130-NC	SX-2145-NC

All Valve Seat Wheels are guaranteed against manufacturing defects for 1 year from original purchase date



2 Angle Valve Seat Wheels

- Use with SX-HOLDER & SX-78 adaptor (page 22)
- 30° one side, 45° on the other side

General Purpose		
Inch	mm	Order No.
2 5/8"	66.0	SXL-2145-GP
3"	76.2	SXL-2345-GP
3 1/2"	88.9	SXL-2545-GP
3 3/4"	92.3	SXL-2645-GP
4"	101.6	SXL-2745-GP

SX-HOLDER





KWIK-WAY
 Seat Grinding Equipment & Supplies
MFG BY

GOODSON

Tools and Supplies for Engine Builders



45° Sioux-Style (SGK) Star Drive Electric Motor Unit

- Heavy duty electric motor
- 11,500 RPM
- Weighs 9 lbs.
- 3/5 HP • 7.5 Amps

Description	Order No.
110V, 50/60Hz	031-3100-21
220V, 50/60Hz	031-3100-28
Nose Assembly	034-3105-00
2 Pc. Brush Set	003-0072-43
Trigger Switch	000-1201-20



Enlarged to show detail

034-3112-00

Replacement Drive Assemblies

- 1/2" x 20 thread
- Easy to install
- Always keep one on hand for emergencies

Description	Order No.
Star Drive (SGH)	034-3112-00

Sioux-Style Valve Seat Grinding Kits

These kits include everything you need to get started in seat grinding. Choose between kits including 110V and 220V Star Drive Electric Grinders. After that, everything else in the kit is identical.

We started with the most common sizes of pilots and valve seat stones, but you can customize one of these kits to meet your specific needs. Call 1-800-533-8010 for additional information.

Description	OE Number	Order No.	Includes	
45° Star Drive Motor Seat Grinding Set (110V, 50/60 Hz)		SGK-110-KIT	▼	
45° Star Drive Motor Seat Grinding Set (220V, 50/60Hz)		SGK-220-KIT	▼	
Star Drive Seat Grinder - 45° 110V, 50/60 Hz	031-3100-21	031-3100-21	1	
Star Drive Seat Grinder - 45° 220V, 50/60 Hz	031-3100-28	031-3100-28	1	
Universal Valve Seat Wheel Dresser w/G-13P Diamond	-----	SWD-UNI	1 1	
Replacement Dressing Diamond	-----	G-13P		
Dressing Stand Pilot	031-0202-55	031-0202-55	1 1	
Stone Holder - 1/8" x 16 Thread	1702	SX-HOLDER	2 2	
Heavy Duty Plastic Storage Box (21 ¹ / ₁₆ " x 12 ¹ / ₂ " x 13 ¹ / ₂ "	001-1000-25	SG-CASE	1 1	
Seat Stone Removal Tool	-----	SX-SRT	1 1	
Bounce Spring Set (3 Pc.)	-----	BSS-100	1 1	
Leather Vibration Reducer (3 Pc.)	-----	SHW-3	1 1	
.385" Top Pilots	Dia./mm			
	.2755" / 7.00mm	P-5275S	1 1	
	.2763" / 7.02mm	P-5277S	1 1	
	.2779" / 7.05mm	P-5278S	1 1	
	.3125" / 7.94mm	P-5312S	1 1	
	.3130" / 7.95mm	P-5313S	1 1	
	.3141" / 7.98mm	P-5314S	1 1	
	.3149" / 8.00mm	P-5315S	1 1	
	.3430" / 8.71mm	P-5343S	1 1	
	.3440" / 8.73mm	P-5344S	1 1	
	.3450" / 8.76mm	P-5345S	1 1	
	.3750" / 9.53mm	P-5375S	1 1	
	.3760" / 9.55mm	P-5376S	1 1	
General Purpose Seat Grinding Stones (1/16"x16)	30°		45°	
1.375" / 35mm	SX-1130-GP	1 1	SX-1145-GP	1 1
1.500" / 38mm	SX-1230-GP	1 1	SX-1245-GP	1 1
1.625" / 41mm	SX-1330-GP	1 1	SX-1345-GP	1 1
1.750" / 44mm	SX-1430-GP	1 1	SX-1445-GP	1 1
1.785" / 47mm	SX-1530-GP	1 1	SX-1545-GP	1 1
2.000" / 51mm	SX-1630-GP	1 1	SX-1645-GP	1 1
2.125" / 54mm	SX-1730-GP	1 1	SX-1745-GP	1 1
Finishing Valve Seat Grinding Stones (1/16"x16)	30°		45°	
1.375" / 35mm	SX-1130-F	1 1	SX-1145-F	1 1
1.500" / 38mm	SX-1230-F	1 1	SX-1245-F	1 1
1.625" / 41mm	SX-1330-F	1 1	SX-1345-F	1 1
1.750" / 44mm	SX-1430-F	1 1	SX-1445-F	1 1
1.785" / 47mm	SX-1530-F	1 1	SX-1545-F	1 1
2.000" / 51mm	SX-1630-F	1 1	SX-1645-F	1 1
2.125" / 54mm	SX-1730-F	1 1	SX-1745-F	1 1

CYLINDER HEAD REBUILDING
 CLEANING, ASSEMBLY & SAFETY
 SHORT BLOCK REBUILDING
 CRANKSHAFT/ FLYWHEEL GRINDING
 MISCELLANEOUS TOOLS & SUPPLIES
 BRAKE SERVICE TOOLING
 MEASURING TOOLS
 V-TWIN & METRIC HARD PARTS



"We replenish our warehouse locations daily so that items are readily available to fill your orders without delay."

- Tracy, Goodson Receiving - 3 years of service

CYLINDER HEAD
REBUILDING

CLEANING,
ASSEMBLY & SAFETY

SHORT BLOCK
REBUILDING

CRANKSHAFT/
FLYWHEEL GRINDING

MISCELLANEOUS
TOOLS & SUPPLIES

BRAKE SERVICE
TOOLING

MEASURING
TOOLS

V-TWIN & METRIC
HARD PARTS

Rebuildable
¹³/₁₆"x13 Thread Hex Drive
Kwik-Way Stone Holder

- Use to replace worn-out holders or save time by having several holders set up with different sizes, compositions or angles of seat stones • Ball-bearing construction
- Without spring plunger
- Use rebuild kit 034-0002-00 (below)
- ¹³/₁₆" x 13 thread
- .437" Pilot Size
- Supersedes KW-3056
- Order No. **031-0300-56**



Rebuildable
¹³/₁₆"x13 Thread Hex Drive
Kwik-Way Stone Holder

- Use to replace worn-out holders or save time by having several holders set up with different sizes, compositions or angles of seat stones • Ball-bearing construction
- With spring plunger
- Use rebuild kit 034-0002-15 (below)
- ¹³/₁₆" x 13 thread
- .437" Pilot Size
- Order No. **031-0300-30**



New-Generation
Hex Drive Stone Holder
For .375" Top Pilot

- Use to replace worn-out holders or save time by having several holders set up with different sizes, compositions or angles of seat stones • Ball-bearing construction
- Without spring plunger
- ¹³/₁₆" x 13 thread
- .375" Pilot Size
- Order No. **KW-375E**



New-Generation
Hex Drive Stone Holder
For .375" Top Pilot

- Use to replace worn-out holders or save time by having several holders set up with different sizes, compositions or angles of seat stones • Ball-bearing construction
- Without spring plunger
- ¹³/₁₆" x 13 thread
- .437" Pilot Size
- Order No. **KW-437**



Accessories	Order No.
Stabilizer Assembly with Bronze Bushing	031-0126-60
Heavy-Duty Twisted Cable Steel Coupling	031-0304-10
Replacement Hex Drive Body Cap	031-0302-95
Replacement Spring Plunger Assembly	031-0313-97
Leather Vibration Reducer (3 pc.) For KW-Holders	KHW-3
Valve Seat Stone Removal Tool	KW-SRT

SX-78

Accessories	Order No.
Sioux-Style Conversion Bushings ¹ / ₁₆ "x16 to ⁷ / ₁₆ "x14	SX-78
Black & Decker ⁵ / ₈ " Hexball ⁵ / ₁₆ "x24 thread	BD-58
³ / ₁₆ "-16 to ¹ / ₁₆ "-16 Adaptor for Sioux Style	BD-60

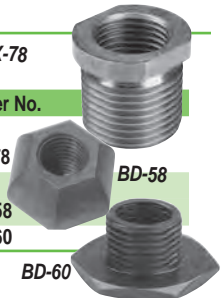

BD-60



Stone Holder Rebuild Kits

For Hex Drive Stone Holder without Spring Plunger Includes 2 Bearings, Bearing Sleeve, Bearing Lock Nut, Sleeve Key, Hex Cap & Garter Spring
Fits OE & Goodson models

Order No. **034-0002-00**



For Hex Drive Stone Holder with Spring Plunger

Includes 2 Bearings, Bearing Sleeve, Bearing Lock Nut, Sleeve Key, Hex Cap & Spring Plunger. Fits OE & Goodson models

Order No. **034-0002-15**



For Flex Drive Stone Holder

Includes 2 Bearings, Bearing Sleeve, Heavy Duty Flex Coupling, Inner Sleeve Key & Set Screw

Order No. **034-0003-25**

Rebuild kit components are not available individually



031-0390-02



031-0391-00



031-0393-04

Grinding Wheel Adaptors

Description	Order No.
¹³ / ₁₆ "-13 (KW) Threaded Stones to ¹ / ₁₆ "-16 Threaded Holders (Sioux™, KO Lee)	031-0390-02
¹³ / ₁₆ "-13 (KW) Threaded Stones to ³ / ₁₆ "-16 Threaded Holders (Black & Decker)	031-0391-00
¹³ / ₁₆ "-13 (KW) Threaded Stones to ² / ₁₂ "-18 Threaded Holders (Kwik-Way)	031-0393-04

Seat Stone Holders, Adaptors, Etc.

11/16" x16 Thread Star Drive Stone Holder

- Use to replace worn-out holders or save time by having several holders set up with different sizes, compositions or angles of seat stones
- Ball-bearing construction
- .385" Top Pilot Size

Description	OAL	OE#	Order No.
Short Body	3 1/2"	1672	SX-1672
Standard Body	4 3/4"	—	SX-HOLDER



11/16" x16 Thread Hex Drive Stone Holder For .375" Top Pilot

- Use to replace worn-out holders or save time by having several holders set up with different sizes, compositions or angles of seat stones
- Ball-bearing construction
- OAL: 5 3/16"
- OE# 1702BB
- .375" Top Pilot Size
- Order No. **SX-1702BB**



11/16" x16 Thread Star Drive Stone Holder For .375" Top Pilot

- Use to replace worn-out holders or save time by having several holders set up with different sizes, compositions or angles of seat stones
- Ball-bearing construction
- OAL: 4 3/4"
- .375" Top Pilot Size
- Order No. **SX-375**



9/16" x16 Thread Black & Decker Style Stone Holder For .375" Top Pilot

- Use to replace worn-out holders or save time by having several holders set up with different sizes, compositions or angles of seat stones
- Ball-bearing construction • OE # BD-HOLDER
- .375" Top Pilot Size
- Includes BD-60 Adaptor to convert to 11/16" x16 thread
- Order No. **BDS-HOLDER**



11/16" x16 Thread Star Drive Stone Holder For .389" Top Pilot

- Use to replace worn-out holders or save time by having several holders set up with different sizes, compositions or angles of seat stones
- Ball-bearing construction
- OAL: 4 3/4"
- OE# 1702
- .389" Top Pilot Size
- Order No. **SUN-HOLDER**

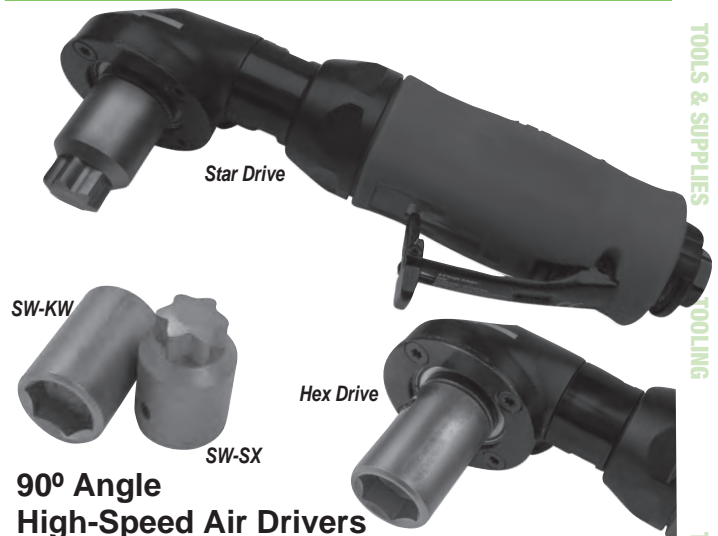

90° Angle High-Speed Air Drivers

- 2 models available - Star or hex drive
- 11,000 RPM motor
- 5/8" - 11 spindle
- 1/4" air inlet • 6 CFM • Rear exhaust
- Weighs 2.25 lbs. • Measures 8.75" long
- Composite grip and trigger are designed for user comfort

Description	Order No.
Star Drive (SGK) 5/8" - 11 spindle	AG-SX90
Hex Drive (SGH) 5/8" - 11 spindle	AG-KW90
Replacement Drive Adaptors (1 1/2" OAL)	
Star-Drive (SGK) Adaptor	SW-SX
Hex Socket (SGH) Adaptor	SW-KW

ADA-BDS
(5/8" Hex)



ADA-SX-HD
(Star)

ADA-KW
(11/16" Socket)

Air Drive Adaptors

- 1/4" shank
- Adaptors available for a variety of stone holders
- Use with bounce springs (page 24) for best results



Description	Order No.
Hexball Driver	5/8" SAE thread ADA-BDS
Kwik-Way Drive Adaptor	1/2" x 20 thread ADA-KW
Sioux-Style Drive Adaptor	Welded style adaptor ADA-SX-HD

CYLINDER HEAD
REBUILDING

CLEANING,
ASSEMBLY & SAFETY

SHORT BLOCK
REBUILDING

CRANKSHAFT/
FLYWHEEL GRINDING

MISCELLANEOUS
TOOLS & SUPPLIES

BRAKE SERVICE
TOOLING

MEASURING
TOOLS

V-TWIN & METRIC
HARD PARTS

Goodson
exclusive

Universal Valve Seat Wheel Dresser Stand

- Infinitely adjustable from 0° to 90°
- Scale marked in 1° increments
- Dress stones up to 4" diameter
- Includes Premium dresser diamond & dresser pilot
- Base has pre-drilled holes for easy mounting to your bench
- **Choose dresser pilot from chart below**

Description	Order No.	Incl.
Universal Dressing Stand	SWD-UNI	▼
Replacement Premium Dressing Diamond	G-13P	x
Dressing Stand Riser Bushings (.250" & .875" Tall)	SK-9-10	x
Dressing Stand Riser Bushings (For .437" dresser pilots)	SK-11-12	

See pages 18-23 for valve seat stones, stone holders, air drivers, etc.

Includes
Premium Dresser Pilot
Choose From
Chart BelowStones and Holders
sold separately

Heavy Duty Valve Seat Wheel Dresser Stand

- Ball bearing mounted diamond carrier
- Adjustable in 1° increments from 0° to 90°
- Includes diamond
- **Choose dressing pilot from list below**
- Designed for maximum accuracy

Description	Order No.
Heavy Duty Dresser	031-1900-02
Replacement Torsion Spring for 031-1900-02	000-1850-78
Replacement Brass Plug	031-1917-00
Replacement Diamond Dresser	G-18

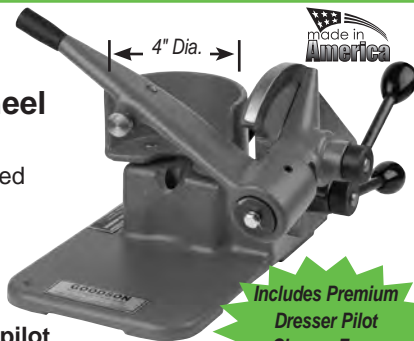
Includes Premium
Dresser Pilot
Choose From
Chart Below**made in
America**

Valve Seat Wheel Dresser Pilots for Universal & Heavy Duty Wheel Dresser Stands

- .437" top pilots include a groove
- All pilots have .625" bottom

Dresser Pilots (select based on stone holder type)		
Fits Stone Holder Type	OAL	Order No.
A .437" Hex Stone Holder	5 1/2"	031-1102-89
B .437" Hex or Flex Stone Holder	7 1/4"	031-0202-80
C .385" Top Stone Holder	6"	031-0202-55
D .375" Top Stone Holder	6 1/2"	031-0202-47

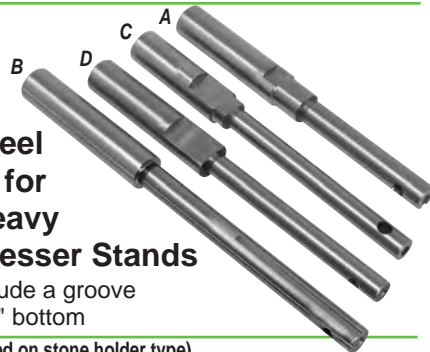

Seat Stone Removal Tool

Once in a while a valve seat stone will be so tight on the stone holder that it's almost impossible to get off. That's why we came up with this tool. Simply fasten it to your bench with screws or bolts (not included) or clamp it in a vise, place the holder onto the fixture and twist the stone off easily.

Description	Order No.
Sioux-Style	SX-SRT
Kwik-Way Style	KW-SRT



Valve Seat Height Gauge

- Adjusts for all popular valve seat diameters • Gauge accurate to .001"
- Seat contact probe aligns on valve seat while gauge rides along the fire deck • Pilot aligns in valve guide
- Fully adjustable seat contact probe and gauge positions allow tool to fit popular seat diameters from .750" to 3.00"
- Includes Dial Indicator

Description	Fits Pilot	Order No.
Valve Seat Height Gauge Kit	.375"	VSHG-375
Replacement Dial Indicator		EDI-1



tech tips Goodson recommends using Bounce Springs with your Valve Seat Stones to prevent damage to the stone and the from the techparts™ seat. This is especially important with the very small stones.

Standard Bounce Spring Set

- Includes 1 each of 3 lengths: 1" / 24.5mm, 1.50" / 38.1mm & 2" / 50.8mm
- ID = .450" / 11.4mm
- OD = .570" / 14.5mm
- Not for use with 3-D Fast Cut
- Order No. **BSS-100**

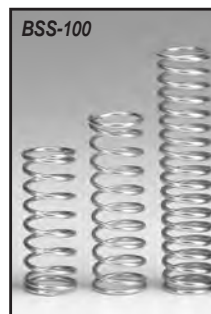

Small Diameter Bounce Springs

- ID = .406" / 10.3mm
- OD = .500" / 12.7mm

Length / mm	Order No.
1.10" / 27.9	BS-1
1.67" / 42.4	BS-2
3.00" / 76.2	BS-3

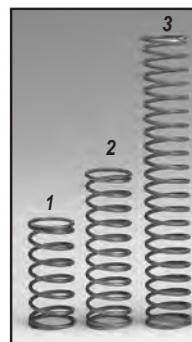

Valve Refacing

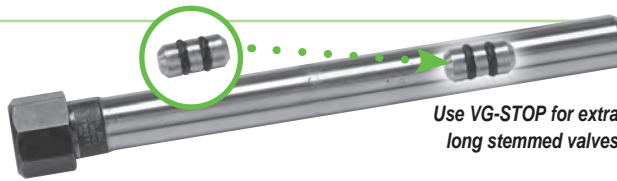

Use VG-STOP for extra long stemmed valves



Find out how to expand the capacity of your valve refacer to accept smaller valves. Scan the code at right with your smart phone or other smart device for instant access.



Adaptor for 1/2" Chucks

- For small diameter valves
- Collet cover range from 2.8mm to 6.5mm
- Hardened steel collet holder fits any machine with a 1/2" chuck
- Collet seats in retainer nut for fast, easy removal
- Internal stop adjusts, allowing you to reface an entire set of valves to identical specs quickly
- Start with the set then replace collets as needed (**collets will not work without the holder**)
- Use the Adaptor Stop to machine longer valve stems

Description	Range	Order No.	Incl.
Full Set		UVRC-46	▼
Steel Collet Holder (collets MUST be used)		UVRC-46R	x
Replacement Collets	2.8 to 3.2mm (.109" to .125")	UVRC-18	
	3.0 to 3.5mm (.118" to .138")	UVRC-3.5MM	
	3.5 to 4.0mm (.138" to .158")	UVRC-4.0MM	x
	4.0 to 4.5mm (.158" to .177")	UVRC-4.5MM	
	4.4 to 4.8mm (.172" to .1875")	UVRC-316	
	4.5 to 5.0mm (.177" to .196")	UVRC-5MM	x
	4.8 to 5.2mm (.1875" to .203")	UVRC-1364	
	5.0 to 5.5mm (.196" to .216")	UVRC-5.5MM	x
	5.5 to 6.0mm (.216" to .236")	UVRC-6.0MM	
	6.0 to 6.5mm (.236" to .256")	UVRC-6.5MM	x
Replacement Nut		UVRC-NUT	
Adaptor Stop		VG-STOP	x



Valve Stem to Valve Face Concentricity Gauge

- Accurate to .001"
- Features a rugged, positive stop – set it once and do an entire set of valves • Use before grinding to eliminate needless cleaning & machine time • Use after refacing to ensure stem concentricity • Also check pilots and other small parts for concentricity
- For stems as small as 4mm
- Order No. VCG-16

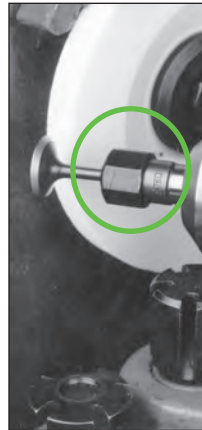

Sun-Dura® Canvas Machine Covers

- Heavy-weight, breathable black Sun-Dura® fabric won't hold in moisture
- Several sizes to fit a variety of machines
- All covers will fit other machines, just match your machine's dimensions to the cover dimensions
- Covers are opaque, pictures for demonstration only

Fits Machine	Dimensions	Order No.
Ring Filter	13"L x 7 1/2"D x 7 1/2"H	GMC-PRF
VST-2000 Spring Tester	10"L x 14"D x 18"H	GMC-VST
AG-Series Precision Gauge	8"L x 8"W x 4"D	GMC-AG300
Rimac Spring Tester	32"dia. x 18 1/2"H (tapers)	GMC-RIMAC



Valve Grinding Aid For Titanium, Stainless & Stellite Valves

- Not water soluble - add to your mineral based Valve Grinding Oil for better finish on titanium, stainless steel and stellite valves
- Mix ratio: 1:4 • Won't hinder your regular valve grinding process
- Seeks out, and bonds to hot metals
- Ideal for grinding hard metal racing valves • 32 oz. / 946 mL
- Order No. VGA-T32

Mix 1 part grinding aid to 4 parts refacer oil

CYLINDER HEAD REBUILDING
CLEANING, ASSEMBLY & SAFETY
SHORT BLOCK REBUILDING
FLYWHEEL GRINDING
CRANKSHAFT/ FLYWHEEL GRINDING
TOOLS & SUPPLIES
BRAKE SERVICE TOOLING
MEASURING TOOLS
V-TWIN & METRIC HARD PARTS

Precision made wheels = superior performance

We stock more than 40 individual valve refacer wheels, each one designed for a specific machine. Our 4" general purpose wheel for Black & Decker is different from our 4" general purpose wheel for Sioux™. We won't compromise on performance just to simplify our inventory. Your valve refacer requires a certain type of grit, grade and bond and Goodson delivers. All Goodson Valve Refacing Wheels are designed to be used with mineral based grinding oils such as VGO-10 or VGO-SD10. Goodson guarantees all valve refacing wheels against manufacturing defects for 1 year from original purchase date.

Choose from these types: **GP** = for general purpose grinding **S** = for grinding Stellite, **T** = for grinding Titanium, and **CB** = for general purpose grinding of harder materials. Stone color may vary due to manufacturing process.

To Fit	Use	Dia x Ht x Arb	Shape	Type	Color	Fits Models	OE No.	Order No.		
Black & Decker	Valve	4" x 1" x 5/8"	Offset	CB	Blue	A, B, C, LW, M, MW, N, NW, NWB	Goodson Spec	GV-146-CB		
		4" x 1" x 3/8"	Offset	S	Ruby	A, B, C, LW, M, MW, N, NW, NWB	16371	GV-144		
		4" x 1" x 5/8"	Offset	GP	Gray	All but 680, 682, 285, 956		GV-147		
		4" x 1" x 5/8"	Offset	GP	Black	All but 680, 682, 285, 956		GV-148		
		4" x 1" x 3/8"	Offset	T	Green	All but 680, 682, 285, 956	Goodson Spec	GV-150		
Comec	Valve	5" x 1" x 5/8"	Offset/20°	GP	Pink	P, PC, PCB, T, TD, TG	34131	GV-156		
		4" x 1 1/8" x 1/2"	Cup	GP	Ruby	All models	20939	GV-145		
		215 x 35 x 76mm	Flared	GP	Gray	VR416, RV-516	7604	GV-925		
Comec	Stem	215 x 35 x 76mm	Flared	S	Brown	VR416, RV-516	Goodson Spec	GV-980		
		100 x 50 x 20mm	Cup	GP	White	VR416, RV-516	7606	GV-928		
IDL Sunnen®	Valve	8" x 1 1/4" x 1 1/2"	Flared	GP	White	CG-50,-80,-82, V-90, VR-7000	8230	GV-823		
		8" x 1 1/4" x 1 1/2"	Flared	GP	Gray	CG-50,-80,-82, V-90, VR-7000	VR1703	GV-825		
		8" x 1 1/4" x 1 1/2"	Flared	S	White	CG-50,-80,-82, V-90, VR-7000	Goodson Spec	GV-821		
		8" x 1 1/4" x 1 1/2"	Flared	T	Green	CG-50,-80,-82, V-90, VR-7000	VR1704	GV-827		
Kwik-Way	Valve	8" x 1 1/4" x 1 1/2"	Flared	GP	Ruby	CG-80, CG-82, V-90, VR-7000	VR1701	GV-824		
		4 1/2" x 7/8" x 7/8"	Offset	GP	Black	CV, SK, KK, VC, SM, SV, XC	010-0450-10	GV-257		
		4 1/2" x 7/8" x 7/8"	Offset	S	Gray	CV, SK, KK, VC, SM, SV, XC	010-0457-03	GV-259		
		5" x 7/8" x 7/8"	Offset	GP	White	EVS, VS	Goodson Spec	GV-251		
		5" x 7/8" x 7/8"	Offset	GP	Gray	EVS, VS	010-0509-01	GV-252		
		5" x 7/8" x 7/8"	Offset	T	Green	EVS, VS	010-0508-04	GV-255		
		7" x 1" x 7/8"	Offset	GP	Gray	SVS, SVS-2	010-0709-00	GV-280		
		7" x 1" x 7/8"	Offset	CB	Blue	SVS, SVS-2	Goodson Spec	GV-280-CB		
		7" x 1" x 7/8"	Offset	S	White	SVS, SVS-2	010-0707-50	GV-281		
		7" x 1" x 7/8"	Offset	T	Green	SVS, SVS-2	010-0708-05	GV-282		
		7" x 1" x 7/8"	Offset	T	Green	SVS, SVS-2	Goodson Spec	GV-282A		
		7" x 1" x 7/8"	Offset	GP	Orange	SVS, SVS-2	Radiac Spec	F372239 Radiac		
		7" x 9/16" x 7/8"	Offset	GP	Ruby	SVS, SVS-2	Radiac Spec	F377419 Radiac		
		8" x 1 3/8" x 7/8"	Offset	GP	Gray	VL	010-0819-04	GV-260		
		KO Lee	Stem	3" x 1 1/4" x 5/8"	Cup	GP	Gray	All Models except VL	Radiac Spec	F336036 Radiac
3" x 1 1/4" x 5/8"	Cup			GP	Gray	All Models except VL	010-0300-05	GV-237		
3" x 1 1/4" x 5/8"	Cup			CB	Blue	All Models except VL	Goodson Spec	GV-237-CB		
KO Lee	Valve	5" x 3/4" x 5/8"	Offset	GP	Gray	All models	OV5GH60	GV-658		
		5" x 3/4" x 5/8"	Offset	S	White	All models	OV5GH80S	GV-659		
	Stem	4" x 1" x 3/8"	Cup	GP	Gray	K500(C) & K403(C)	RV4KH60	GV-345		
		4" x 1" x 5/8"	Cup	CB	Blue	All	Goodson Spec	GV-345-CB		
Rottler	Valve	7" x 1" x 7/8"	Offset	GP	Gray	VR-7, VR-10	VTRW-8	GV-280		
		7" x 1" x 7/8"	Offset	CB	Blue	VR-7, VR-10	Goodson Spec	GV-280-CB		
		7" x 1" x 7/8"	Offset	T	Green	VR-7, VR-10	VTRW-7	GV-282		
		7" x 1" x 7/8"	Offset	S	White	VR-7, VR-10		GV-281		
		7" x 1" x 7/8"	Offset	T	Green	VR-7, VR-10	Goodson Spec	GV-282A		
		7" x 1" x 7/8"	Offset	GP	Orange	VR-7, VR-10	Radiac Spec	F372239 Radiac		
		7" x 1" x 7/8"	Offset	GP	Ruby	VR-7, VR-10	Radiac Spec	F377419 Radiac		
		9" x 1 1/4" x 1 1/2"	Offset	GP	Orange	VR-9, VR-12		GV-725		
		9" x 1 1/4" x 1 1/2"	Offset	S	Pink	VR-9, VR-12		GV-726		
		9" x 1 1/4" x 1 1/2"	Offset	T	Green	VR-9, VR-12		GV-727		
		9" x 1 1/4" x 1 1/2"	Offset	S	Ruby	VR-9, VR-12	Nitrite Coated Diesel	GV-728		
		Rottler	Stem	3" x 1 1/4" x 5/8"	Cup	GP	Gray	VR-7, VR-10	VTRW-9	GV-237
				3" x 1 1/4" x 5/8"	Cup	CB	Blue	All Models except VL	Goodson Spec	GV-237-CB
3" x 1 1/4" x 5/8"	Cup			GP	Gray	VR-7, VR-10	Radiac Spec	F336036 Radiac		
100 x 50 x 20mm	Cup			GP	White	VR416, VR-516, VTRW-3	7606	GV-928		

Colors may vary due to manufacturing processes. All valve refacing wheels are guaranteed for 1 year from original purchase date.



Valve Refacing Wheels

Colors may vary due to manufacturing processes. All valve refacing wheels are guaranteed for 1 year from original purchase date.



To Fit	Use	Dia x Ht x Arb	Shape	Type	Color	Fits Models	OE No.	Order No.	
Skil Snap-On	Valve	5" x 3/4" x 5/8"	Offset	GP	Gray	All models	7556/VW80	GV-658	
		5" x 3/4" x 5/8"	Offset	S	White	All models	VW80S	GV-659	
Sioux™	Stem	4" x 1" x 5/8"	Cup	GP	Gray	All but Skil 491	7557/VR2M89	GV-345	
		4" x 1" x 5/8"	Cup	CB	Blue	All but Skil 491	Goodson Spec	GV-345-CB	
	Valve	4" x 1" x 5/8"	Offset	CB	Blue	All but 680, 682, 285, 956	Goodson Spec	GV-146-CB	
		4" x 1" x 5/8"	Offset	GP	Gray	All but 680, 682, 285, 956	78SP	GV-147	
		4" x 1" x 5/8"	Offset	GP	Black	All but 680, 682, 285, 956	78E	GV-148	
		4" x 1" x 5/8"	Offset	S	Ruby	All but 680, 682, 285, 956	Goodson Spec	GV-144	
		4" x 1" x 5/8"	Offset	T	Green	All but 680, 682, 285, 956	Goodson Spec	GV-150	
		5" x 1" x 5/8"	Offset/20°	GP	Pink	Thor 299 & 300	Goodson Spec	GV-156	
		7" x 1 1/16" x 1 3/4"	Str./15°	GP	Orange	680, 956, 2001 & 2075	Goodson Spec	GV-270	
		7" x 1 1/16" x 1 3/4"	Str./15°	CB	Blue	680, 956, 2001 & 2075	Goodson Spec	GV-270-CB	
		7" x 1 1/16" x 1 3/4"	Str./15°	S	White	680, 956, 2001 & 2075	177	GV-271	
		7" x 1 1/16" x 1 3/4"	Str./15°	T	Green	680, 956, 2001 & 2075	174	GV-272	
		7" x 1 1/16" x 1 3/4"	Str./15°	GP	Ruby	2001, 2075, 680 & 956	Radiac Spec	A379613 <small>Radtec</small>	
		7" x 1 1/16" x 1 3/4"	Str./15°	T	Green	2001, 2075, 680 & 956	Radiac Spec	A340229 <small>Radtec</small>	
		Stem	4" x 1" x 5/8"	Cup	GP	Gray	All but 682 & 685	81 (73533)	GV-345
4" x 1" x 5/8"	Cup		CB	Blue	All but 682 & 685	Goodson Spec	GV-345-CB		
Sunnen® (TA) S&D	Valve	6" x 1 1/16" x 3/4"	Flared	GP	Black	VR6500, all S&D	Sunnen Spec	VR602	
		6" x 1 1/16" x 3/4"	Flared	GP	Black	VR6500, all S&D	VR602	GV-766	
		6" x 1 3/8" x 3/4"	Flared	T	Black	VR6500, all S&D	Sunnen Spec	VR603	
		6" x 1 3/8" x 3/4"	Flared	S	Black	VR6500, all S&D	Sunnen Spec	VR604	
		6" x 1 3/8" x 3/4"	Flared		Black	VR6500, all S&D	Sunnen Spec	VR605	
		6" x 1 3/8" x 3/4"	Cup		Black	TR6700 Tappet Grinder	Sunnen Spec	VR606	
		6" x 1 3/8" x 3/4"	Flared	GP	Black	TR6700	Sunnen Spec	VR607	
		6" x 1 3/8" x 3/4"	Flared	GP	Gray	VR6500	Radiac Spec	F345291 <small>Radtec</small>	
		6" x 1 3/8" x 3/4"	Flared	GP	Black	VR7000, VR8000	Sunnen Spec	VR1702	
		6" x 1 3/8" x 3/4"	Flared		Black	VR7000, VR8000	Sunnen Spec	VR1703	
		6" x 1 3/8" x 3/4"	Flared	T	Gray	VR7000, VR8000	Sunnen Spec	VR1704	
		Stem	5" x 1 3/8" x 3/4"	Cup	S	White	VR6500, all S&D	Sunnen Spec	VR601
			6" x 1 3/8" x 3/4"	Cup	GP	Black	VR7000, VR8000	Sunnen Spec	VR1701
	Winona Van	Valve	5" x 3/4" x 5/8"	Off./Bev.	GP	Gray	E, Y, YW, X, XA	75399	GV-658
5" x 3/4" x 5/8"			Off./Bev.	S	White	K500HM, K403CM	75400	GV-659	
Norman	Stem	4" x 1" x 5/8"	Cup	GP	Gray	All but 500 & CRW	40352	GV-345	
		4" x 1" x 5/8"	Cup	CB	Blue	All but 500 & CRW	Goodson Spec	GV-345-CB	

Colors may vary due to manufacturing processes. All valve refacing wheels are guaranteed for 1 year from original purchase date.

Mineral Based Valve Grinding Oil

- Long-lasting
- Cools while grinding
- Removes particles for a better finish
- Inhibits rust
- Prevents rancidity, foaming & deposits



Quantity	Order No.
1 gallon / 3.79 L	VGO-10
5 gallons / 18.93 L	VGO-50

Severe Duty Mineral Based Valve Refacer Oil For Titanium, Inconel®, Stainless Steel & Stellite

- Mineral Based
- Includes additives to improve cutting performance under high pressure



Size	Order No.
1 gallon / 3.79 L	VGO-SD10
5 gallons / 18.93 L	VGO-SD50

CYLINDER HEAD REBUILDING
CLEANING, ASSEMBLY & SAFETY
SHORT BLOCK REBUILDING
FLYWHEEL GRINDING
CRANKSHAFT/ TOOLS & SUPPLIES
MISCELLANEOUS
BRAKE SERVICE
MEASURING TOOLS
V-TWIN & METRIC HARD PARTS



"In addition to the wide selection of tools and supplies found in this catalog, we have access to hundreds more hard-to-find tools. If you're looking for a special tool, call us and we'll help you find it."

- Cheryl, Goodson Purchasing, 2 years of service

CYLINDER HEAD
REBUILDING



Replacement Belts For Kwik-Way Valve Refacers

Application	Machine	Order No.
1 Spindle Belt 14.5" L "O" Ring - 1 Pr.	SVS II	000-2303-62
2 Chuck Belt 10" Cog, 50 tooth	SVS II	001-1899-90
3 Spindle Belt 18" Serpentine	SVS	001-1905-20
4 Chuck Belt 12" Cog, 60 tooth	SVS or VS	001-1899-99
5 Spindle Belt 16" V-Belt	VS	001-1900-67
6 Chuck Belt 19" 120 tooth	VS	001-1900-75

CLEANING,
ASSEMBLY & SAFETY

SHORT BLOCK
REBUILDING

CRANKSHAFT/
FLYWHEEL GRINDING

Replacement Chuck Balls For Kwik-Way Valve Refacers

- Measure chuck ball diameter before ordering to ensure correct replacement • 6 per set

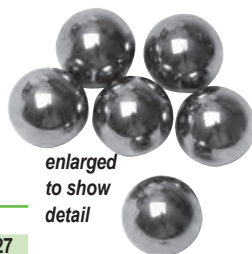

enlarged
to show
detail

Diameter	Order No.
1/2"	010-2101-27
17/32"	010-2101-35

MISCELLANEOUS
TOOLS & SUPPLIES



Replacement Bearing Cap for Sioux™ 1710 Electric Driver

- Order No. **SX-23694**

Replacement Brush Set for Sioux™ 1710 Electric Driver

- Carbon brushes for armature
- Measure 3/8" x 1/2"
- Order No. **SX-18004**

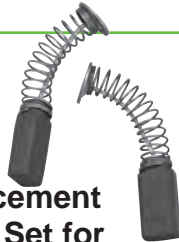

BRAKE SERVICE
TOOLING

MEASURING
TOOLS

Replacement Switch for Sioux™ 1710 Electric Driver With Plastic Handle

- 125/250 VAC or 125VDC
- 2 Pole • Measures 1.87"L x 0.875"W x 1.07"H
- Order No. **SX-18204**



Replacement Bearing Cap for Sioux™ 1792 Pneumatic Driver

- Order No. **SX-33970**



V-TWIN & METRIC
HARD PARTS

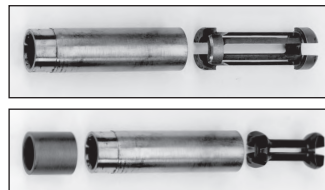

◀ Collet is unavailable from OE

◀ Replace with two-piece set

Collet for Black & Decker™ Valve Refacers

- Two-piece set replaces the Black & Decker Twin Grip collet (no longer available)
- Remove the damaged, worn or broken collet and replace with this set
- Accommodates 1/4" (6.35mm) to 3/8" (9.53mm) valve stems
- Order No. **BVR-38**

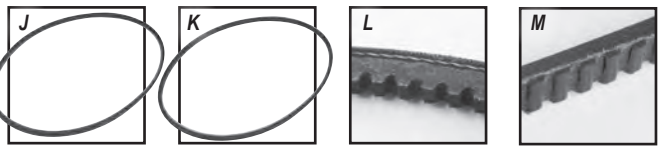
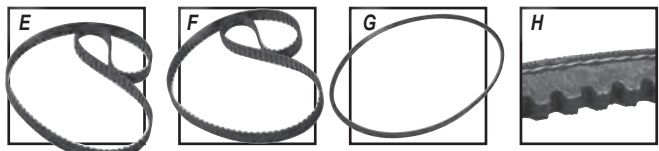
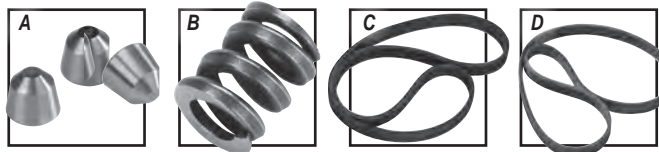

special order Many more replacement parts available

Replacement Parts for Sioux™ Valve Refacers

Description	Fits Model No.	Order No.
A- Chuck Balls (3 pc.)	680, 2075	24185
B- Chuck Springs (9 Pc.)	680, 2075	SX-53615
C- Spindle Belt 28"x1/2" 5 groove	2075	SX-65117
D- Serpentine 29"x1/2" 5 grooves	680	SX-14471
E- Cog Style 24"x1/2" 120 teeth	680	SX-14467
F- Chuck Belt 23"x3/8", 115 teeth	2075	SX-14473
G- Replacement Belt for Grinding Head Fits Serial #s up to 34999 (2 belts)	645	SX-14400
H- Chuck Belt Fits Serial #s 34999 & up (also coolant pump belt for #s 35217 & up).	645	SX-14401
J- Belt for Motor Shaft; Fits Serial #s up to 34999	645	SX-14402
K- Coolant Pump Belt; Fits Serial #s 34999-35216	645	SX-14403
L- Replacement Belt for Grinding Head; Fits Serial #s 35000-58700	645	SX-14453
M- Replacement Belt for Grinding Head; Fits Serial #s 58701 & up	645	SX-14461
N- Belt for Motor Shaft; Fits Serial #s 35000 & up	645	SX-14445
O- Replacement Switch (1100V, AC)	2001, 2075	SX-18221

Replacement Parts

CYLINDER HEAD
REBUILDING

CLEANING,
ASSEMBLY & SAFETY

SHORT BLOCK
REBUILDING

CRANKSHAFT/
FLYWHEEL GRINDING

MISCELLANEOUS
TOOLS & SUPPLIES

BRAKE SERVICE
TOOLING

MEASURING
TOOLS

V-TWIN & METRIC
HARD PARTS

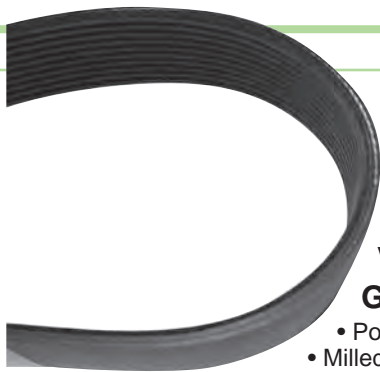

Replacement V-Belts for Sunnen® VGS-20 Seat & Guide Machine

- Poly V-Belts
- Milled construction
- Shippable worldwide

Application	Length	Replaces OE#	Order No.
Drive	22"	PDB-310A/ST-467X	VGS-20-22
Countershaft	30"	PDB-309A/ST-467W	VGS-20-30



Valve Refacer Steady Rest Shoes for Sunnen® VR-7000 & VR-8000

- Sold by the pair
- Order No. SUN-1202A

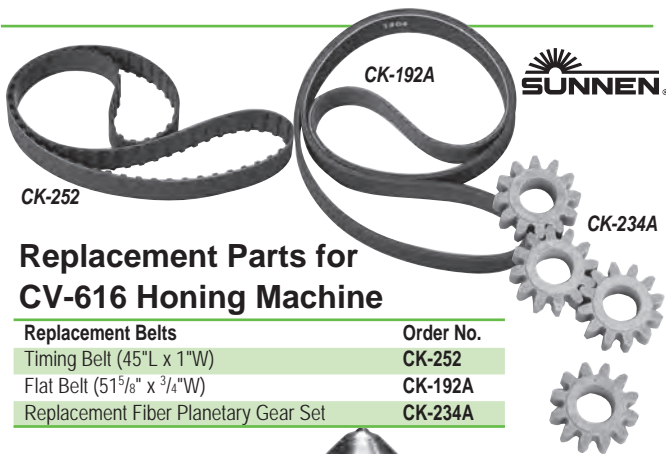

Replacement Parts for CV-616 Honing Machine

Replacement Belts	Order No.
Timing Belt (45"L x 1"W)	CK-252
Flat Belt (51 ⁵ / ₈ " x 3 ³ / ₄ "W)	CK-192A
Replacement Fiber Planetary Gear Set	CK-234A

Sunnen VR-6500 Valve Refacer Replacement Belts

- 2 sizes available
- Shippable worldwide

Belt Type	Length	OE Number	Order No.
Drive Belt	11"	PDB-305A	VR-6500-11
Jack Shaft Belt	17"	PDB-306A	VR-6500-17
Splindle Belt	23"		VR-6500-23

Diamond dressers shown at approximately actual size

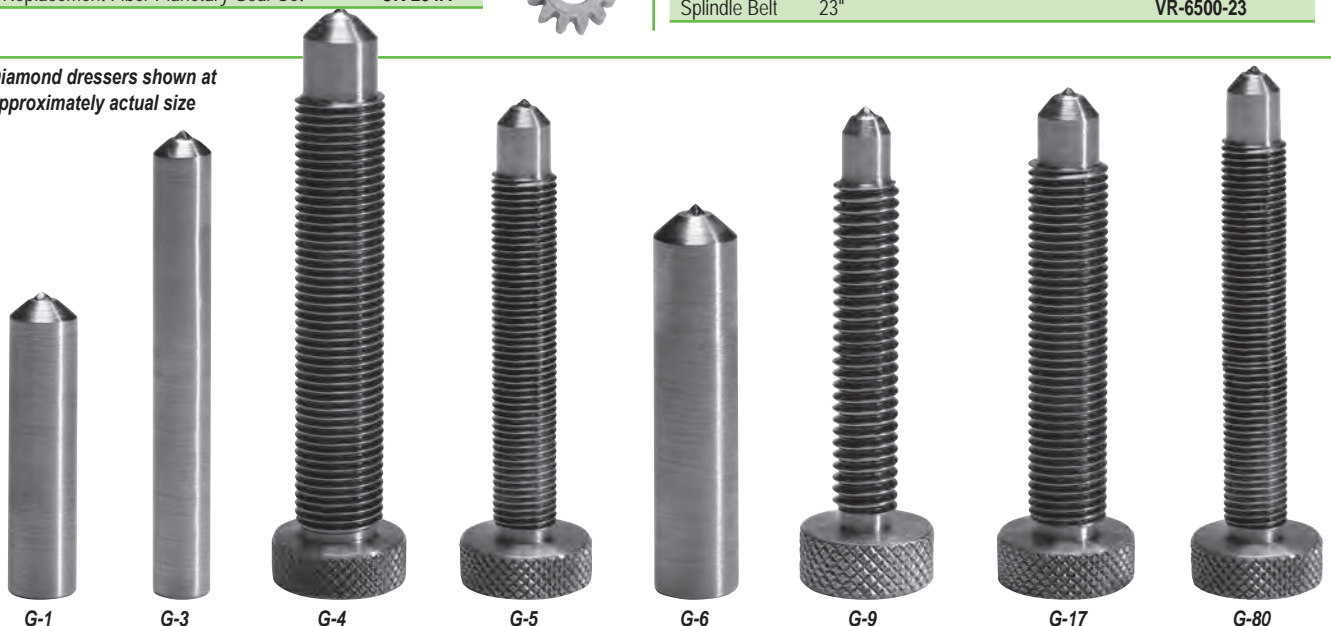

Diamond Dresser Tools for Common Valve Refacers

• Select from Standard or Premium Grade • See the complete assortment of diamond dresser tools on pages 114 and 115.

Machine	Description	Carat	Standard	Premium
Valve Refacers	B&D, Skil, Sioux™, Thor, VanDorn, WVN	3/8" x 1 5/8"	G-1	G-1P
	Kwik-Way, Tobin Arp (S&D)	5/16" x 2 1/2"	G-3	---
	Kwik-Way, Valve Master (1714)	1/2" x 3 1/4" 20NF	G-4	---
	Sioux™ (1713, 1715), IDL, WVN (CG50, CG80)	3/8" x 2 3/4" 24NF	G-5	G-5P
	IDL, WVN (CG50, CG80)	3/8" x 3 1/4" 24NF	G-80	---
	US	7/16" x 2"	G-6	---
	Skil (Talent)	5/16" x 2 1/4" 18NC	G-9	---
	Kwik-Way	7/16" x 2 3/4" 20NF	G-17	G-17P



"I make sure all Goodson products are packaged properly and include instructions and other important information for you."

- Craig Goodson Receiving - 9 years of service

tech tips

from the techxperts™
For best results,
limit speed to
175 RPM

**High Speed Steel
Core Drill/Reamers**

- Save time – drill and ream in a single pass
- Top-quality, high speed steel
- Prepares the guide bore for standard OD valve guide inserts
- Several shank designs to fit most Seat & Guide machines
- For best results limit speed to 175 RPM

Fits	Size	mm	Order No.
Peterson and K.I.	.375" x .500"	9.5x12.7	CDR-6197G
½" round shank			
Serdi	.275" x .437"	7.0x11.1	CDR-7192G
¾" with flat	.275" x .500"	7.0x12.7	CDR-7193G
	.312" x .437"	7.9x11.1	CDR-7194G
	.312" x .500"	7.9x12.7	CDR-7195G
	.343" x .500"	8.7x12.7	CDR-7196G
	.375" x .500"	9.5x12.7	CDR-7197G
Cobalt Core Drills/	.275" x .437"	7.00x11.1	CDR-274-CB
Reamers	.275" x .500"	7.00x12.7	CDR-275-CB
½" round shank			
	.311" x .5628"	7.90x14.3	CDR-563-CB
	.312" x .500"	7.92x12.7	CDR-312-CB
	.343" x .500"	8.71x12.7	CDR-343-CB
	.373" x .625"	9.47x16.5	CDR-625-CB
	.375" x .500"	9.53x12.7	CDR-375-CB

High Speed
Steel Core Drill/
Reamers are
62 to 64 Rc

Steam-Oxide
Coating for Chip
Lubricity



**sized for
diesel**



**Valve Guide Tooling
For 5.9 L, 24 Valve, 7mm Cummins**

- To replace integral guides used in this diesel cylinder head
- Replacement guides are .502/.511" stepped to use with OE or replacement seals below

Description	Order No.	Includes
Complete Kit	CVG-KIT	▼
Tooling Kit Only	CVG-59KIT	▼
A Core Reamer (.426" pilot, .485" shank)	CCR-59	1 1
B Core Drill (7mm pilot, .429" shank)	CCD-59	1 1
C Guide Driver (7.0mm)	PHL-2235-G	1 1
D Cast Iron Valve Guide (Exhaust)	CIG-3022	12
E Cast Iron Valve Guide (Intake)	CIG-3021	12
F Exhaust Seals (12 pk.)	CVS-59E	1
G Intake Seals (12 pk.)	CVS-59i	1

tech tips

This application requires you to perform all machining and guide installation from the spring side of the head.



Piloted Core Drills and Reamers

- CNC-machined to .0003" T.I.R. or less
- Ideal for any Bridgeport-type (collet driven) machine
- Use dry at 175 to 225 RPM

Piloted Core Drills

- Center accurately in the guide
- Cutting angle prevents the bit from wandering due to irregular guide wear
- Flutes are designed to enlarge bores quickly

Precision Reamers

- Pilot size is carefully matched to the OD of the related core drill
- Assures accurate location of the reamer for smooth, vibration free operation
- Gives proper interference fit to match manufacturer specifications



Find out more about Piloted Core Drills & Reamers. Scan the code at right with your smart phone or other smart device for instant access



High Speed
Steel Core Drill/
Reamers are
65 to 67 Rc

Bronze-Oxide
Coating for
Chip Lubricity



**sized for
diesel**

Core Drills				Core Reamers		
OD	Pilot	OE No.	Order No.	OD	OE No.	Order No.
DCM Tech, .4687"	.312"	DP-1550	DPP-1511B	.500"	66-02147, RR-115	DRR-115
Peterson / K.I. ½" Round						
Sunnen® / .490"	.312"	VGS-156A	DTA-2082B	.500"	VGS-162A	DRT-2097
Tobin-Arp .490"	.343"	VGS-152A	DTA-2082	.500"	VGS-162A	DRT-2097
½" with Flat .490"	.371"	VGS-153A	DTA-2083	.500"	VGS-162A	DRT-2097
Universal .429"	7mm		CCD-59	.4365"	Use for Ford 6.0L Diesel	FCR-60-1
.429" Round Shank	7mm		CCD-59	.4375"	Use for Ford 6.0L Diesel	FCR-60
	7mm		CCD-59	.5000-.5003"	Use for 24V Cummins	CCR-59
				.562"	.500" pilot	CCR-562B
				.550"	Use for 12V, 5.9 Cummins	CCR-550

Note: For the best performance, Core Drills and Reamers should be used in matched pairs. If you order a drill slightly smaller or larger than the OE specification to fit your machine, please order the matching reamer listed immediately to the right of the drill in the table.

CYLINDER HEAD REBUILDING
CLEANING, ASSEMBLY & SAFETY
SHORT BLOCK REBUILDING
CRANKSHAFT/ FLYWHEEL GRINDING
MISCELLANEOUS TOOLS & SUPPLIES
BRAKE SERVICE TOOLING
MEASURING TOOLS
V-TWIN & METRIC HARD PARTS

Bronze Reaming Oil

- Prevents build-up • Extends reamer life • Improves valve guide finish

Size	Order No.
1 Pint / 473.2mL	BW-303-G
1 Quart / 946.4mL	BW-303A-G
1 Gallon / 1.893L	BW-305-G



tech tips For best results always use Carbide Reamers with Bronze Reaming Oil (BW-303A-G)

Extended non-cutting pilot section for easier alignment with the guide

Pilot portion of reamer features 4 flutes to deliver more cutting oil to the work piece

Reamer body features 8 flutes to cut bronze valve guides quickly, accurately and repeatably

tech tips Once used on cast iron, do NOT use on bronze.

Small Reamers for Cast Iron or Bronze

- Premium quality reamers with tough cobalt flutes for long life in cast iron or bronze • Square drive shank
- Use at 200 to 300 RPM
- OAL is 4.50" (nominally)

Inch	mm	Shank Dia.	Drive Dia.	Order No.
.1575"	4.00	.152"	.112"	MR-4MM
.1771"	4.50	.173"	.112"	MR-4.5MM
.1968"	5.00	.187"	.138"	MR-5.0MM
.1980"	5.03	.187"	.136"	MR-198
.2165"	5.50	.206"	.162"	MR-5.5MM
.2360"	6.00	.224"	.160"	MR-6.0MM
.2755"	7.00	.246"	.182"	MR-7.0MM

Solid Carbide Valve Guide Reamers Specifically Designed For Use Only With Bronze Guides

- Unique 8-flute body design with 4-flute pilot for longer tool life
- Cutting geometry requires less torque to drive the reamer
- More rigid tool construction
- Faster feeds than conventional design
- Non-cutting pilot allows easier alignment with guide
- Simply the best bronze valve guide reamer we've created!
- Use at 300 to 400 RPM • OAL: 6.00" (nominal)
- Pilot measures approximately .005" smaller than cutting diameter

Inch	mm	Order No.	Inch	mm	Order No.
.1771"	4.50	HGR-4.5MM*	.3115"	7.91	HGR-3115
.1968"	5.00	HGR-5.0MM*	.3120"	7.92	HGR-3120
.2165"	5.50	HGR-5.5MM*	.3141"	7.98	HGR-3140
.2362"	6.00	HGR-6MM	.3150"	8.00	HGR-8MM
.2750"	7.00	HGR-7MM	.3410"	8.66	HGR-3410
.2766"	7.03	HGR-2766	.3420"	8.69	HGR-3420
.2770"	7.04	HGR-2770	.3425"	8.70	HGR-3425
.3110"	7.90	HGR-3110	.3430"	8.71	HGR-3430
			.3435"	8.72	HGR-3435
			.3440"	8.74	HGR-3440

*Pilot, Flute & Shank Dimensions slightly smaller; call for specific details

CYLINDER HEAD REBUILDING
CLEANING, ASSEMBLY & SAFETY
SHORT BLOCK REBUILDING
FLYWHEEL GRINDING
CRANKSHAFT/ TOOLS & SUPPLIES
MISCELLANEOUS
BRAKE SERVICE TOOLING
MEASURING TOOLS
V-TWIN & METRIC HARD PARTS



High Speed Steel Finish Reamers Exclusively for Cast Iron

Precision size cast iron guides. Piloted and made from the finest tempered steel. With proper care, these reamers will accurately size multiple guides without losing their efficient cutting action. **NOT for hardened or bronze guides.** Use at 400 to 500 RPM. Pilot area measures .012" smaller than cutting diameter.

3/16" Square Drive		
Inch	mm	Order No.
.2165"	5.50	WR-5.5MM-G
.217"	5.51	WR-217-G
.218"	5.54	WR-218-G
.236"	6.00	WR-6MM-G
.250"	6.35	WR-250-G
.256"	6.50	WR-6.5MM-G
.260"	6.60	WR-260-G
.273"	6.93	WR-273-G
.274"	6.96	WR-274-G
.275"	6.99	WR-275-G
.2755"	7.00	WR-7MM-G
.276"	7.01	WR-276-G
.277"	7.03	WR-277-G
.278"	7.06	WR-278-G
.281"	7.14	WR-281-G

1/4" Square Drive		
Inch	mm	Order No.
.310"	7.87	WR-310-G
.311"	7.90	WR-311-G
.312"	7.92	WR-312-G
.313"	7.95	WR-313-G
.314"	7.98	WR-314-G
.315"	8.00	WR-8MM-G
.316"	8.03	WR-316-G
.317"	8.05	WR-317-G
.341"	8.66	WR-341-G
.342"	8.69	WR-342-G
.343"	8.71	WR-343-G
.3435"	8.72	WR-3435-G
.344"	8.74	WR-344-G
.345"	8.76	WR-345-G
.346"	8.79	WR-346-G
.354"	9.00	WR-9MM-G
.355"	9.02	WR-355-G
.356"	9.04	WR-356-G
.358"	9.09	WR-358-G

1/4" Square Drive		
Inch	mm	Order No.
.372"	9.45	WR-372-G
.373"	9.47	WR-373-G
.374"	9.50	WR-374-G
.375"	9.52	WR-375-G
.376"	9.55	WR-376-G
.377"	9.58	WR-377-G
.378"	9.60	WR-378-G
.379"	9.63	WR-379-G
.380"	9.65	WR-380-G
.386"	9.80	WR-386-G
.394"	10.00	WR-10MM-G
.395"	10.03	WR-395-G
.405"	10.29	WR-405-G
.433"	11.00	WR-11MM-G
.436"	11.07	WR-436-G
.437"	11.10	WR-437-G
.453"	11.51	WR-453-G
.472"	12.00	WR-12MM-G
.499"	12.67	WR-499-G
.500"	12.70	WR-500-G

tech tips from the techxperts™

For best results, use high speed steel finish reamers exclusively on cast iron. Ream without oil.

See page 37 for Drive Adaptors

... another satisfied customer

"I have been using the Goodson Hyper-Finish Diamond Valve Guide Hone for years. It makes quick and easy work for valve guide sizing. It will not load up, keeps the guide straight and true and gives great results every time. Best money I've spent on a tool."

- Wes Brown, Cycle-Rama, Inc., Pinellas Park, Florida, Goodson customer since 1999

CYLINDER HEAD REBUILDING

CLEANING, ASSEMBLY & SAFETY

SHORT BLOCK REBUILDING

CRANKSHAFT/ FLYWHEEL GRINDING

MISCELLANEOUS TOOLS & SUPPLIES

BRAKE SERVICE TOOLING

MEASURING TOOLS

V-TWIN & METRIC HARD PARTS



Introduced to the World Market in 2010!

Black Diamond Hyper-Finish™ Valve Guide Sizing System

The **NEW** Black Diamond Hyper-Finish Diamond Valve Guide Sizing System is better than ever. CNC manufactured tooling now has greater accuracy, more durability and better quality. Mandrels are made of black anodized hard plated steel. Not for use on Aluminum Heads.

With this easy-to-use system you can size guides from .193" to .389" (5.00 to 9.90mm) just by switching out mandrels. Mandrels also sold individually. The Drive Head (**HF-100**) fits every size mandrel assembly shown in the chart below, features a quick change set-up and now has an extended reach for more flexibility. Hyper-Finish Tooling is **NOT** interchangeable with the Sunnen® Valve Guide Hone Set (p. 34). Use at 200 RPMs max. **NOTE: BHFS-040 & BHFS-050 are the only replacement abrasives that will fit old style mandrels.**

Size	Range		Mandrel Assembly (abrasive & mandrel)	Abrasive Length	Replacement Abrasive	Replacement Mandrel	Drive Head	Guide Brush
	inch	mm						
5.0mm	.193"-.203"	4.90 - 5.15mm	BHFM-193C	40mm	BHFS-010	BHFM-193	HF-100	GVP-9N
5.5mm	.212"-.232"	5.40 - 5.90mm	BHFM-212C	40mm	BHFS-020	BHFM-212	HF-100	GVP-10N
6.0mm	.232"-.253"	5.90 - 6.40mm	BHFM-232C	40mm	BHFS-020	BHFM-232	HF-100	GVP-10N
6.5mm	.251"-.271"	6.40 - 6.90mm	BHFM-251C	40mm	BHFS-020	BHFM-251	HF-100	GVP-11N
7.0mm	.271"-.311"	6.90 - 7.90mm	BHFM-271C	80mm	BHFS-040*	BHFM-271	HF-100	GVP-11N
.312"	.311"-.350"	7.90 - 8.90mm	BHFM-307C	80mm	BHFS-050*	BHFM-307	HF-100	GVP-1N
.343"	.334"-.374"	8.50 - 9.50mm	BHFM-344C	80mm	BHFS-050*	BHFM-344	HF-100	GVP-2N
.375"	.350"-.389"	8.90 - 9.90mm	BHFM-350C	80mm	BHFS-050*	BHFM-350	HF-100	GVP-3N

Included in Master Kit

*Only these replacement abrasives will fit old style mandrels



Diamond Abrasive produces 25 RA finish in soft guides and 8-10 RA in hardened guides. Every mandrel-abrasive assembly is quality checked to ensure it is true and on size.

Choose from the Standard Master Kit or Build Your Own!

Standard Master Kit includes: Driver Head, 4-Mandrel Assemblies (see chart above), 4-Nylon Valve Guide Brushes (7mm to 3/8") and 8 oz. Diamond Honing Oil.
Order No. **BHF-KIT**

Custom Kit includes: Driver Head, 4-Mandrel Assemblies (select from chart above), 4-Nylon Valve Guide Brushes (you pick the sizes - see chart above) and 8 oz. Diamond Honing Oil.
Order No. **BHF-KIT-CUSTOM**



Goodson
exclusive



Adjustable hose lets you direct coolant right where you need it

1/2" diameter holes (18) and 1" diameter holes (2) drilled in the top plate provide ample tool storage

Perforated steel grate lets oil through and can be removed for cleaning

Rolled front edge directs splashed coolant back into the sump

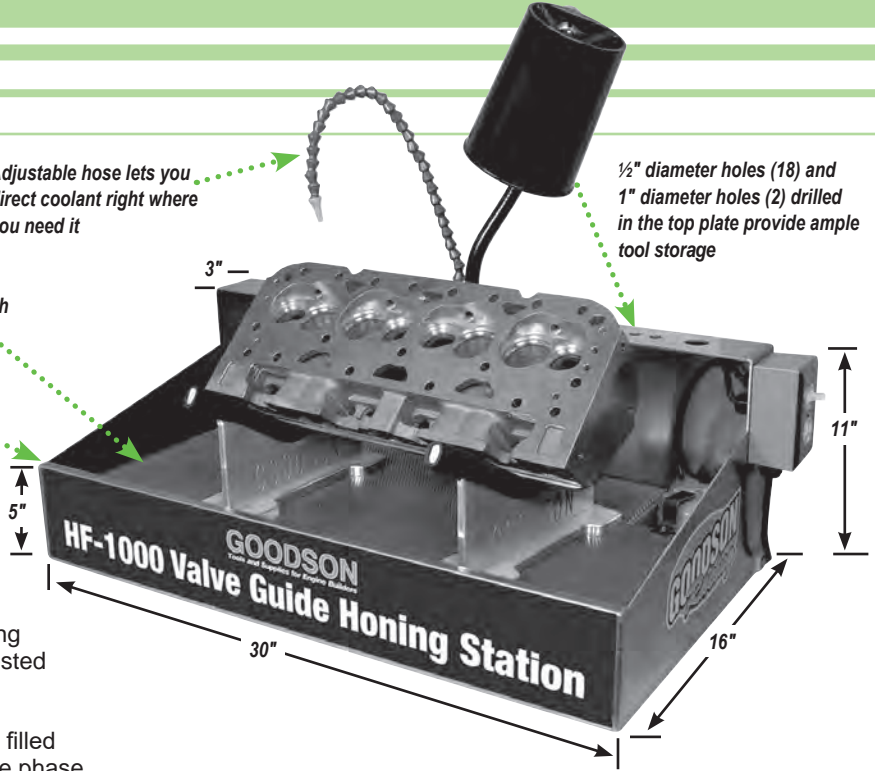

Benchtop Valve Guide Finishing Station

This Goodson designed valve guide finishing station incorporates the features you requested such as:

- Large 5-gallon capacity coolant sump
 - Integral high output pump - 1/150 HP oil filled submersible pump, 115V 60 cycle, single phase heavy-duty motor
 - Aluminum construction for durability and easy cleaning
 - Perforated steel grate allowing used coolant through to recirculate
 - Removable steel grate for easy maintenance
 - Built-in, easy-to-reach storage for tools
- Buy the complete kit and save!**

Description	Order No.	Incl.
Complete 110V Valve Guide Finishing Station Kit	HF-1000KIT	▼
Honing Station Only - 110V	HF-1000	x
Universal Head Holders	HH-200	x
Pump 110V	HF-PUMP	x
5 Gallons Diamond Honing Oil	DHO-50	x

Export voltage available, contact Goodson for additional information

3/16" diameter shank pilot

Carbide or High Speed Steel Valve Guide Top Cutters

- Matches Seat & Guide machine pilots

Description	Shank	Order No.
Cutters 1 1/4" High-Speed Steel	.500"	GFH-100
1 1/4" Carbide	.500"	GFC-200
1 1/4" High-Speed Steel	.486"	GFH-300
Shank Pilots 3/16" (.1875")	.312" (7.93mm)	GFP-312
.343" (8.73mm)	.343" (8.73mm)	GFP-343
.375" (9.53mm)	.375" (9.53mm)	GFP-375
.437" (11.11mm)	.437" (11.11mm)	GFP-437
.500" (12.70mm)	.500" (12.70mm)	GFP-500

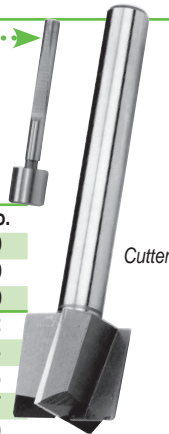

Valve Guide Top Collar

- Supports guide top during machining
- Protects against damage or breakage
- Ideal for high-performance work, and for installing thin-wall liners (pages 38-39)

Size	Range	Order No.
.500"	.496" -.504"	VGC-502
.530"	.526" -.534"	VGC-530
.566"	.562" -.570"	VGC-566

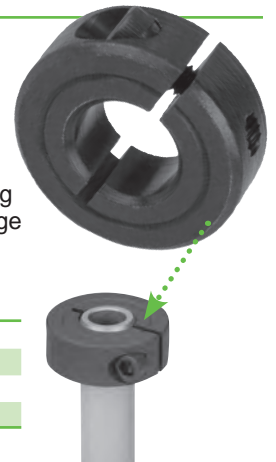

Diamond Honing Oil

- For high pressure honing
- Recommended for use with Black Diamond Valve Guide Sizing System

Size	Order No.
8 oz./237mL	DHO-8
1 Gallon/3.79L	DHO-10
5 Gallons/18.93L	DHO-50



Valve Guide OD Chamfer Tool

- Improve oil deflection
- Universal cutter chamfers any OD from 1/4" to 5/8" (6.35-15.9mm)
- Most precise when used in a Seat and Guide Machine
- Order No. **GCT-35**



CYLINDER HEAD REBUILDING

CLEANING, ASSEMBLY & SAFETY

SHORT BLOCK REBUILDING

CRANKSHAFT/ FLYWHEEL GRINDING

MISCELLANEOUS TOOLS & SUPPLIES

BRAKE SERVICE TOOLING

MEASURING TOOLS

V-TWIN & METRIC HARD PARTS

full service
...fast



"We take our job of getting your order to you quickly very seriously. We use several different carriers allowing us to get your products to you when you need them at a price you can afford."

- Ashley, Goodson Shipping Department, 3 years of service

CYLINDER HEAD
REBUILDING

CLEANING,
ASSEMBLY & SAFETY

SHORT BLOCK
REBUILDING

CRANKSHAFT/
FLYWHEEL GRINDING

MISCELLANEOUS
TOOLS & SUPPLIES

BRAKE SERVICE
TOOLING

MEASURING
TOOLS

V-TWIN & METRIC
HARD PARTS



Valve Guide Hone Set

- Sets-up fast • Easy to use!
- Produces straight, round holes for top-quality work
- Ideal for high-performance applications
- Use a low RPM, 1/2" drill for driving power (200 RPM max.)
- Silicon-Carbide Roughing & Finishing Stones
- Sunnen® tooling is NOT interchangeable with Goodson Black Diamond Hyper-Finish (page 32)

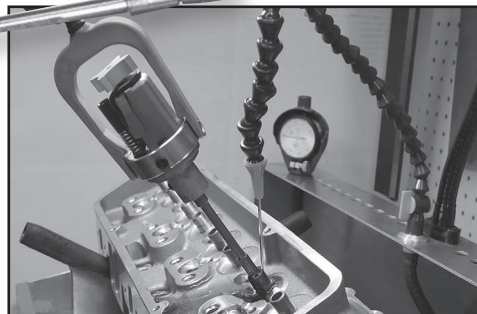
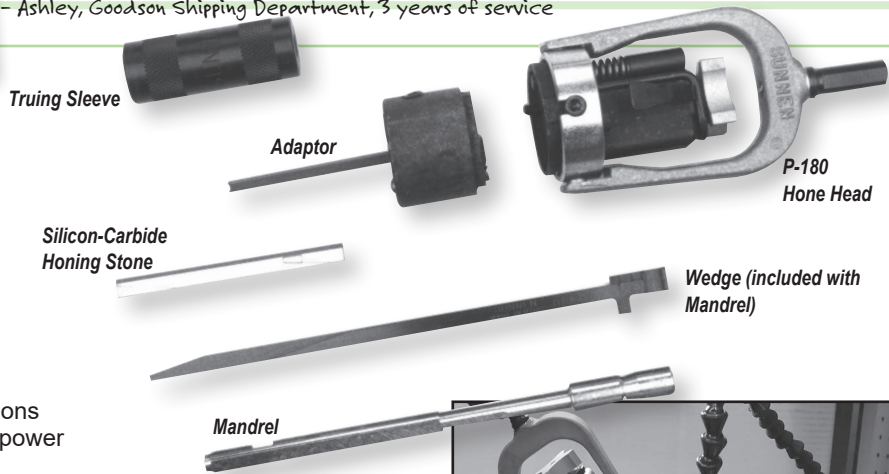

Description	Order No.
Sunnen Honal® Valve Guide Hone Set	P-190
Includes: Head & Driver. Mandrels & Sleeves (1 of ea. for sizes - 5/16", 11/32", 3/8", & 7/16")	
Adaptors: (1) PK10-A & (1) PK12-A. Stones L10-J69 & L12-J67. Case & instructions	
Sunnen Honal® Valve Guide Hone Head & Driver only	P-180
BL Mandrels (Order Mandrel, Sleeve, Stones, Adaptor & Stone Retainer Separately)	

Range			Mandrel	Sleeve	Roughing Stones	Finishing Stones	Adaptor	Stone Retainer
Size	Inch	mm	Order No.	Order No.	Order No.	Order No.	Order No.	Order No.
3.8mm	.150"-.156"	3.8-3.9	BL5150CS	S150	L5J67 (12)	L5J95 (12)	PSK6-A ‡	LN3025C
4.5mm	.175"-.180"	4.4-4.6	BL5175CS	S175	L5J67 (12)	L5J95 (12)	PSK6-A ‡	LN3025C
5mm	.195"-.200"	4.9-5.1	BL6-195CS	S-195	L6-J47 (12)	L6-J67 (12)	PSK6-A ‡	LN-3087C
5.5mm	.210"-.215"	5.3-5.5	BL6-210CS	S-210	L6-J47 (12)	L6-J67 (12)	PSK6-A ‡	LN-3087C
	.215"-.220"	5.5-5.6	BL6-215CS	S-215	L6-J47 (12)	L6-J67 (12)	PSK6-A ‡	LN-3087C
6mm	.225"-.230"	5.7-5.8	BL6-225CS	S-225	L6-J47 (12)	L6-J67 (12)	PSK6-A ‡	LN-3087C
	.230"-.235"	5.8-6.0	BL6-230CS	S-230	L6-J47 (12)	L6-J67 (12)	PSK6-A ‡	LN-3087C
6.6mm	.235"-.240"	6.0-6.1	BL6-235CS	S-235	L6-J47 (12)	L6-J67 (12)	PSK6-A ‡	LN-3087C
	.245"-.250"	6.2-6.4	BL8-245AS	S-245	L8-J47 (6)	L8-J67 (6)	PK8-A	_____
7mm	.250"-.255"	6.4-6.5	BL8-250AS	S-250	L8-J47 (6)	L8-J67 (6)	PK8-A	_____
	.255"-.260"	6.5-6.6	BL8-255AS	S-255	L8-J47 (6)	L8-J67 (6)	PK8-A	_____
7mm	.270"-.275"	6.8-7.0	BL8-270AS	S-270	L8-J47 (6)	L8-J67 (6)	PK8-A	_____
	.275"-.280"	7.0-7.1	BL8-275AS	S-275	L8-J47 (6)	L8-J67 (6)	PK8-A	_____
5/16" ♦	.308"-.316"	7.8-8.0	BL10-308AS	S-308	L10-J47 (6)	L10-J69 (6)	PK10-A	_____
11/32" ♦	.339"-.347"	8.6-8.8	BL10-339AS	S-339	L10-J47 (6)	L10-J69 (6)	PK10-A	_____
23/64"	.354"-.362"	9.0-9.2	BL10-354AS	S-354	L10-J47 (6)	L10-J69 (6)	PK10-A	_____
3/8" ♦	.370"-.385"	9.4-9.8	BL12-370AS	S-370	L12-J47 (6)	L12-J67 (6)	PK12-A	_____
7/16" ♦	.432"-.447"	11.0-11.4	BL12-432AS	S-432	L12-J47 (6)	L12-J67 (6)	PK12-A	_____

♦ Included in set Order No. P-190 ‡NOTE: Remove the stone retainer included with the PSK6-A and replace with LN-3087C for valve guide honing



Ordering Information: The head and driver are interchangeable with the adaptors. Only one head and driver is required. Mandrels are available to cover all popular sizes. Please select from the parts in the photo above and order per size range desired. We suggest you have an adaptor for each mandrel to save change-over time between sizes.

5 Piece Nylon Bristle Valve Guide Brush Set

- Complete kit includes five popular nylon bristle brush sizes
- Brushes measure from 5/16" to 1/2" diameter x 2 1/2" L
- Overall Length: 12"
- For more sizes see page 64
- Order No. **GVP-SET**

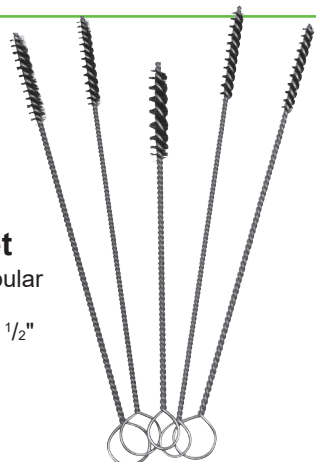

6 Piece Valve Guide Flex-Hone® Set

- Kit includes the most popular sizes for valve guide work
- 240 Grit Silicon-Carbide

Size	mm	OAL	Order No.	Incl.
6 Pc. Valve Guide Kit				VGF-KIT ▼
1/4"	6.4	8"	VGF-6.4MM	x
3/8"	7.0	8"	VGF-7MM	x
5/16"	8.0	8"	VGF-8MM	x
11/32"	9.0	8"	VGF-9MM	x
3/8"	10.0	8"	VGF-10MM	x
7/16"	11.0	8"	VGF-11MM	x

More Valve Guide Flex-Hones® on page 83



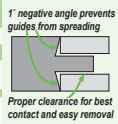

Valve Guide Replacement

Valve Guide Drivers

- Corrosion-resistant finish 1° negative angle prevents guides from spreading • Rockwell hardness of 45-50
- Pilots are slightly smaller than guide ID for easy removal



Powered Drivers			
Standard Sizes	Order No.	Incl.	
4-piece Kit	PH-2226-G	▼	
Guide ID /mm	Driver OD	Pilot	
.312" / 7.92	.487" / 12.4	.300" / 7.62	PH-2228A-G
.312" / 7.92	.423" / 10.7	.304" / 7.72	PH-2228-G
.343" / 8.71	.422" / 10.7	.336" / 8.53	PH-2229A-G
.343" / 8.71	.487" / 12.4	.337" / 8.56	PH-2229-G
.372" / 9.47	.487" / 12.4	.367" / 9.32	PH-2231-G
.437" / 11.10	.612" / 15.5	.429" / 10.90	PH-2230-G
Metric Sizes	Order No.	Incl.	
6-piece Kit	PH-2600-G	▼	
Guide ID /in.	Driver OD	Pilot	
5.0mm / .196"	9.0 / .355"	4.75 / .187"	PH-2250-G
5.5mm / .217"	10.5 / .412"	5.21 / .205"	PH-2255-G
6.0mm / .236"	10.5 / .412"	5.72 / .225"	PH-2260-G
6.6mm / .260"	11.8 / .463"	6.30 / .248"	PH-2234-G
7.0mm / .275"	11.0 / .432"	6.60 / .260"	PH-2235-G
8.0mm / .315"	11.7 / .462"	7.80 / .307"	PH-2236-G
9.0mm / .353"	12.4 / .487"	8.81 / .347"	PH-2237-G
10mm / .393"	15.5 / .612"	9.82 / .387"	PH-2238-G
11mm / .433"	15.5 / .612"	10.85 / .427"	PH-2239-G

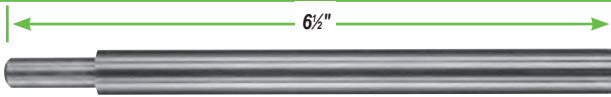

Manual Drivers			
Standard Sizes	Order No.	Incl.	
4-piece Kit	GP-500A-G	▼	
Guide ID /mm	Driver OD	Pilot	
.312" / 7.92	.422" / 10.7	.305" / 7.75	GP-431-G
.312" / 7.92	.487" / 12.4	.302" / 7.67	GP-531-G
.343" / 8.71	.422" / 10.7	.336" / 8.53	GP-533-G
.343" / 8.71	.487" / 12.4	.336" / 8.53	GP-534-G
.372" / 9.47	.487" / 12.4	.367" / 9.32	GP-537-G
.437" / 11.10	.611" / 15.5	.428" / 10.87	GP-743-G
Metric Sizes	Order No.	Incl.	
6-piece Kit	GP-600M-G	▼	
Guide ID /in.	Driver OD	Pilot	
6.6mm / .260"	11.7 / .462"	6.22 / .245"	GP-6.6MM-G
7mm / .275"	10.7 / .422"	6.78 / .267"	GP-7MM-G
8mm / .315"	12.3 / .484"	7.77 / .306"	GP-8MM-G
9mm / .353"	12.3 / .484"	8.84 / .348"	GP-9MM-G
10mm / .393"	15.5 / .611"	9.82 / .387"	GP-10MM-G
11mm / .433"	15.5 / .611"	10.82 / .426"	GP-11MM-G



Air Hammer

- Delivers 3500 blows per minute
- Weighs 3 lbs.
- .401" tool opening

Description	Order No.
Air Hammer	AH-335
Replacement Retainer Spring	AH-5RS

Universal Driver Tool

- Will fit Diesel Guide Drivers at right to increase your reach
- 4.75" OAL
- .401" ID
- Order No. **CL-7333**

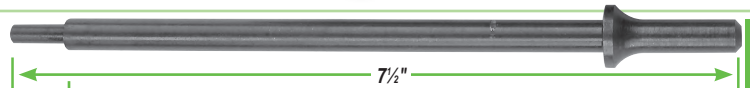

Extra-Long Powered Valve Guide Drivers

- For use with overhead cam heads
- 1° negative angle to prevent guide mushrooming
- Pilots are slightly smaller than guide ID • 7.5" long

Guide ID / in.	Driver OD	Pilot	Order No.
4.0mm / .157"	9.0 / .355"	3.80 / .150"	PHL-2240-G
4.5mm / .177"	9.0 / .355"	4.30 / .170"	PHL-2245-G
5.0mm / .196"	9.0 / .355"	4.75 / .187"	PHL-2250-G
5.5mm / .217"	10.5 / .412"	5.21 / .205"	PHL-2255-G
6.0mm / .236"	9.1 / .358"	5.72 / .225"	PHL-2258-G
6.0mm / .236"	10.5 / .412"	5.72 / .225"	PHL-2260-G
6.6mm / .260"	11.8 / .463"	6.29 / .248"	PHL-2234-G
7.0mm / .275"	11.0 / .432"	6.60 / .260"	PHL-2235-G
7.9mm / .312"	10.7 / .423"	7.72 / .304"	PHL-2228-G
8.0mm / .315"	11.7 / .462"	7.80 / .307"	PHL-2236-G
8.7mm / .343"	12.4 / .487"	8.56 / .337"	PHL-2229-G
9.5mm / .375"	12.4 / .487"	9.32 / .367"	PHL-2231-G

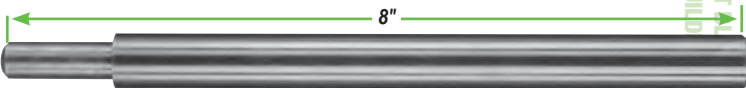

Extra Long Manual Valve Guide Drivers

- 8" OAL • Pilot approximately 1" long
- NOTE:** Due to the nature of these valve guide drivers, they cannot be warranted against breakage, but are guaranteed for dimensional accuracy.

Guide ID / in.	Driver OD	Pilot	Order No.
4.0mm / .157"	9.0 / .355"	3.80 / .150"	GPL-2240-G
4.5mm / .177"	9.0 / .355"	4.30 / .170"	GPL-2245-G
5.0mm / .196"	9.0 / .355"	4.75 / .187"	GPL-2250-G
5.5mm / .217"	10.5 / .412"	5.21 / .205"	GPL-2255-G
6.0mm / .230"	9.1 / .358"	5.72 / .225"	GPL-2258-G
6.0mm / .236"	10.5 / .412"	5.72 / .225"	GPL-2260-G

sized for **diesel**

Air-Powered Valve Guide Drivers for Diesel Engines

- Drive guides in from the shoulder instead of from the top
- Installing drivers have the proper recess to drive guides in for the correct installed height
- Remove / Install guides faster – no measuring necessary
- For most standard pneumatic tools

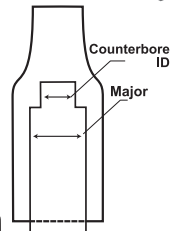
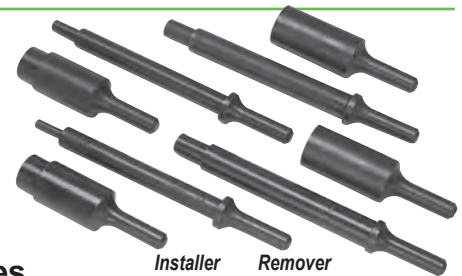

Application	Installer Major/ Counter Bore ID	Order No.	Remover Shank/Pilot OD	Order No.
Cummins	.752" / .503"	DVG-Ci	.595" / .450"	DVG-CR
Cummins 8.3. 6CT	.552" / —	DVG-8.3	.491" / .304"	DVG-71R
Caterpillar 3116	.515" / .475"	DVG-3116	.491" / .304"	DVG-71R
Caterpillar 3126	—	—	.595" / .354"	DVG-3468R
Caterpillar 3406-3408	.709" / —	DVG-3468i	.595" / .354"	DVG-3468R
Detroit GMC 53	.502" / .421"	DVG-53i	—	—
Detroit GMC 71/92	—	—	.491" / .304"	DVG-71R
International DT 466	—	—	.595" / .354"	DVG-3468R



"We work hard to have the right stock at the right price at the right time so you get your orders on time."

- Nancy, Goodson Inventory Fulfillment Manager, 29 years of service

CYLINDER HEAD
REBUILDING



tech tips
from the techxperts™

Install guides to same height every time!

CLEANING,
ASSEMBLY & SAFETY

SHORT BLOCK
REBUILDING

CRANKSHAFT/
FLYWHEEL GRINDING

MISCELLANEOUS
TOOLS & SUPPLIES

BRAKE SERVICE
TOOLING

MEASURING
TOOLS

V-TWIN & METRIC
HARD PARTS

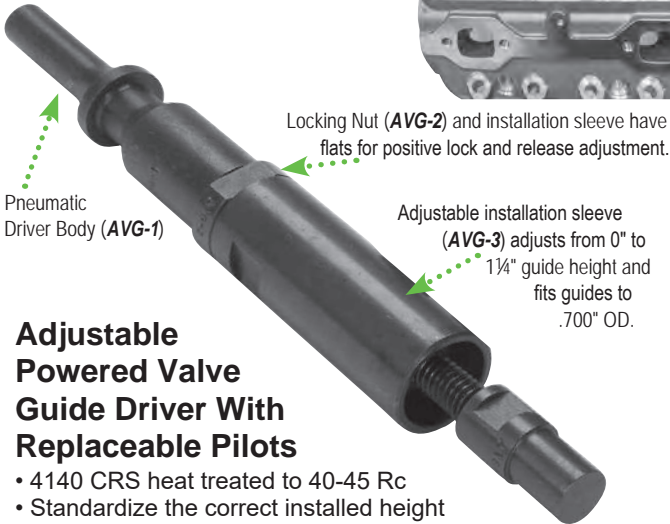

Pneumatic Driver Body (AVG-1)

Locking Nut (AVG-2) and installation sleeve have flats for positive lock and release adjustment.

Adjustable installation sleeve (AVG-3) adjusts from 0" to 1 1/4" guide height and fits guides to .700" OD.

Adjustable Powered Valve Guide Driver With Replaceable Pilots

- 4140 CRS heat treated to 40-45 Rc
- Standardize the correct installed height on one guide then repeat it on all others
- Screw-in pilots with 5/16" - 18 threads • 6 1/2" overall length

Description	Order No.	Includes
Standard Valve Guide Driver Kit	AVG-STD	▼
Metric Valve Guide Driver Kit	AVG-MM	▼
Pneumatic Body Only 5/8" - 18 thread	AVG-1	x x
Installation Sleeve	AVG-3	x x
Locking Nut	AVG-2	x x
Replaceable Pilots	Diameter	
	.312"	AVG-312 x
	.343"	AVG-343 x
	.372"	AVG-372 x
	.437"	AVG-437 x
	5.0mm	AVG-5MM x
	5.5mm	AVG-55MM
	6.0mm	AVG-6MM x
	7.0mm	AVG-7MM x
	8.0mm	AVG-8MM x
	9.0mm	AVG-9MM

Use thread locker on pilot to resist loosening while in use.

Valve Guide OD Machining Tool

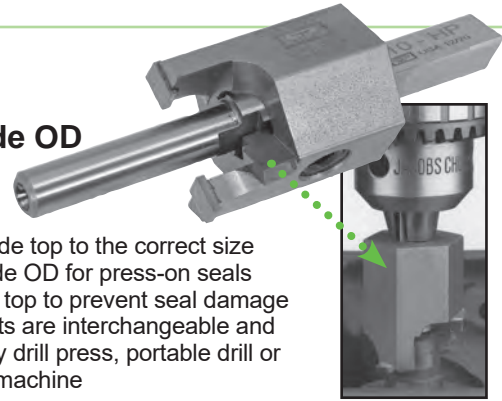

- Faces the guide top to the correct size
- Sizes the guide OD for press-on seals
- Chamfers the top to prevent seal damage
- Cutters & pilots are interchangeable and chuck into any drill press, portable drill or seat & guide machine

Individual Cutters		
Guide OD		Order No.
.415"	10.5	VSC-415
.428"	10.8	VSC-428
.475"	12.1	VSC-475
.495"	12.6	VSC-495
.500"	12.7	VSC-500
.530"	13.5	VSC-530
.562"	14.3	VSC-562
.625"	15.9	VSC-625

Cutter and Pilot Assemblies				
Guide OD		Pilot Size		Order No.
.415"	10.5	.312"	7.9	VSC-415312
.420"	10.7	.312"	7.9	VSC-420312
.428"	10.9	.312"	7.9	VSC-428312
.475"	12.1	.312"	7.9	VSC-475312
.475"	12.1	.343"	8.7	VSC-475343
.500"	12.7	.275"	7.0	VSC-500275
.500"	12.7	.312"	7.9	VSC-500312
.500"	12.7	.343"	8.7	VSC-500343
.500"	12.7	.375"	9.5	VSC-500375
.530"	13.5	.312"	7.9	VSC-530312
.530"	13.5	.343"	8.7	VSC-530343
.530"	13.5	.375"	9.5	VSC-530375
.562"	14.3	.343"	8.7	VSC-562343
.562"	14.3	.375"	9.5	VSC-562375
.625"	15.9	.375"	9.5	VSC-625375

Pilots		
Guide ID	Order No.	
.275"	7.0	VP-7MM
.312"	7.9	VP-312
.343"	8.7	VP-343
.375"	9.5	VP-375

tech tips
from the techxperts™

Right Hand Rotation Only.

For best results, keep your RPM about the same as your hone RPM, use the same rate of speed and number of strokes per minute.



Ultra-Finish Plateau Valve Guide Soft Hones

- Use AFTER guide honing to remove microscopic peaks and scuffs without enlarging the guide ID
- Abrasive impregnated nylon bristles
- Use with liberal amounts of honing oil
- Not interchangeable with Flex-Hones®
- Use with your portable drill or seat and guide machine

Hole Diameter	Hone	Head	Overall		Order No.
in	mm	Dia.	Length	Length	
.2187"	5.5	.241"	1.00"	4.00"	UF-5.5MM
.2500"	6.4	.275"	1.25"	4.50"	UF-6.4MM
.2813"	7.0	.309"	1.25"	4.50"	UF-7MM
.3125"	8.0	.343"	1.25"	4.50"	UF-8MM
.3437"	9.0	.378"	1.25"	4.50"	UF-9MM
.3750"	10.0	.413"	1.25"	4.50"	UF-10MM

NOTE: Larger size Ultra-Finish hones on page 92



Watch for the Made In America symbol throughout the catalog

This symbol indicates products manufactured within the United States. We are proud to feature products made by US manufacturers, including many right in our own back yard of Winona, Minnesota.

tech tips
from the techxperts™
Use with Knurlube

Knurling Arbors

- Piloted for positive centering
- Use by hand or with electric drill & speed reducer
- **Not for use on chilled, hardened or bronze guides**

Inch	mm	Drive	Order No.
.236"	6.00	.1875"	WKA-6MM-G
.275"	7.00	.1875"	WKA-7MM-G
.312"	7.92	.2500"	WKA-312-G
.343"	8.71	.2500"	WKA-343-G
.375"	9.53	.2500"	WKA-375-G
1 Quart Knurlube (946.6mL)			WLB-47-G



Electric Drill Drive Adaptors For Knurling Arbors and/or Reamers

Use **WSR-41-3-G** (1/4" sq.) and **WSR-41-4-G** (3/16" sq.) include the **WSR-41-7-G** (3/8" drill adaptor). Clamp 3/8" drive in drill to drive reamers directly.

Description	Order No.
A Drill Adaptor for 3/8" drill	WSR-41-7-G
B 1/4" Adaptor for arbors/reamers larger than .281"	WSR-41-3-G
C 3/16" Adaptor for arbors/reamers .281" or smaller	WSR-41-4-G
D Slip on Adaptor (converts WSR-41-3-G to .1875")	WSR-41-5-G

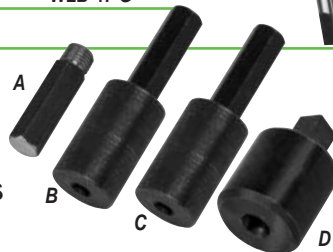

Knurlube

- High pressure lube prevents tool damage
- Extends knurler life by reducing friction and arbor wear

Size	Order No.
8 oz. / 236.6mL	WLB-46-G
32 oz. / 946.4mL	WLB-47-G



Bronze Reaming Oil

- Prevents build-up
- Extends reamer life
- Improves valve guide finish

Size	Order No.
16 oz. / 473.2mL	BW-303-G
32 oz. / 946.4mL	BW-303A-G
1 Gal. / 1.893L	BW-305-G



Valve Guide OD Knurling Tool

- Enlarge guides to fit bore
- Ideal for rare metric sizes and aluminum heads with damaged guide bores
- Works on most materials, **except** chilled or hardened guides

Description	Order No.
Complete Tool	VGK-25
Replacement Knurling Wheel	VGK-25W
Replacement Knurling Rollers (2)	VGK-25R



tech tips
from the techxperts™

Hold guide firmly in Vise, Drill Press or Seat & Guide machine; tighten the knurler and turn it around the guide **by hand**. Increase OD up to .002".

Harley valve guides on page 134

Cast Iron False Valve Guides

Universal Applications

ID	OD	Length	Order No.
.312"	.439"	2.281"	CIG-312
.342"	.502"	3.062"	CIG-342
.372"	.502"	2.750"	CIG-372
.343"	.564"	2.750"	OG-343
.373"	.564"	2.750"	OG-373

24 Valve 7mm Cummins Diesel (.511" seal surface) see tooling, page 30

ID	OD	Length	Order No.	
Intake	.275"	.502"	1.940"	CIG-3021
Exhaust	.275"	.502"	2.020"	CIG-3022

Ford 6.0L (.513" x .659" seal surface) see tooling, page 30

ID	OD	Length	Order No.	
	.275"	.4395"	2.332"	CIG-3055

7.3 Powerstroke Use with Core Drill Reamer CDR-563-CB, page 30

ID	OD	Length	Order No.	
	.3146"	.5652"	2.440"	CIG-8476



Manganese Bronze False Valve Guides

Universal Applications

ID	OD	Length	Order No.
.311"	.439"	3.062"	BVG-311
.343"	.502"	2.375"	BVG-343
.372"	.502"	2.375"	BVG-372

Cast Iron and Manganese Bronze Valve Guides for Harley-Davidson on page 134

Universal Repair Guides

- Unfinished ID ready to be reamed with Goodson's exclusive carbide reamers (page 31)
- Manganese bronze

ID	OD	Length	Order No.
7.0mm	.740"	2.700"	UVBG-7MM
.308"	.740"	2.700"	UVBG-308
.341"	.740"	2.700"	UVBG-341
.372"	.740"	2.700"	UVBG-372



Get QualCast Valve Guides from your friends at Goodson

Goodson offers the complete line of QualCast Products for High Performance, Standard Duty and Heavy Duty vehicle engines. Visit the QualCast section of the Goodson website for listings.

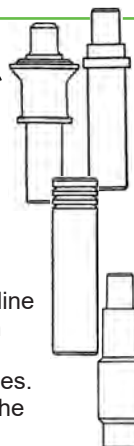

Scan the code below with your smart phone or other device for fast access to the QualCast Valve Guide listings on the Goodson website



... another satisfied customer

"I have been using your products for over 30 years and have never had an issue. Your phone staff is friendly and helpful; my parts are packaged perfectly and the quality of your products is excellent. Keep up the good work."

— Brad Mattei, Mattei's Cycle Supply, New Orleans, LA, Goodson Customer Since 1990

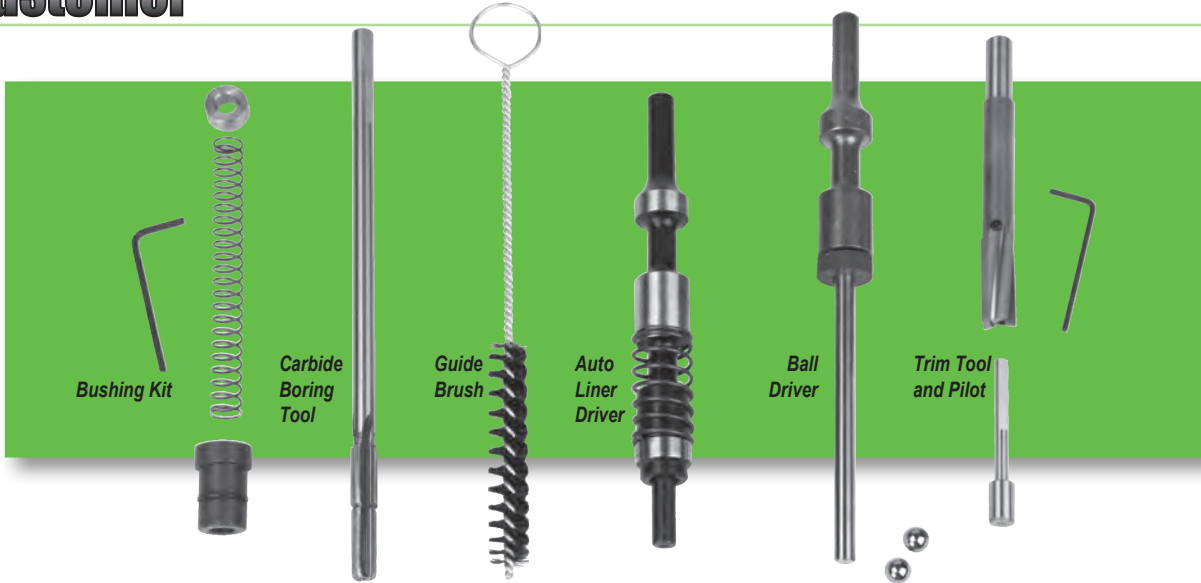

6.0mm to 3/8" Bronze-Liner Installation Tool Kits

Phosphor-Bronze is an ideal valve guide material – it's more durable than cast iron, conducts heat away faster and retains lubrication better to reduce wear. Install rugged, thin-wall (.030") Bronze-Liners in cast iron or aluminum heads to repair guides and deliver performance better than new! Plus, Bronze-Liners install quickly with simple tools. If a Bronze-Liner ever wears out, you can quickly and easily replace it with a new one to restore performance. **Removal Tools, page 39.**

Kits include ▼	6.0mm Guides		7.0mm Guides		5/16" Guides	
Master Tool Kits		CL-6MM		CL-7MM		CL-312
Carbide Boring Tool		CL-2024C		CL-2007C		CL-2005C
Bushing Kit		CL-2003		CL-2001		CL-2000
Ball Driver		CL-4452P		CL-4446P		CL-4444P
Carbide Sizing	.2370"	CL-5237	.2770"	CL-5277	.3125"	CL-53125
Balls	.2380"	CL-5238	.2780"	CL-5278	.3130"	CL-5313
Auto-Driver		CL-3600		CL-3507		CL-3500
Trim Tool	.402" OD	CL-5602	.500" OD	CL-5600	.500" OD	CL-5600
Trim Tool Pilot		CL-5634		CL-5626		CL-5620
Guide Brush		GVP-10N		WCB-44		WCB-44

When Working By Hand, Kits Require Seat Centering Cones - See Chart Below

Kits include ▼	8.0mm Guides		11/32" Guides		3/8" Guides	
Master Tool Kits		CL-8MM		CL-343		CL-375
Carbide Boring Tool		CL-2008C		CL-2012C		CL-2014C
Bushing Kit		CL-2000		CL-2000		CL-2000
Ball Driver		CL-4444P		CL-4444P		CL-4444P
Carbide Sizing	.3160"	CL-5316	.3440"	CL-5344	.3750"	CL-5375
Balls	.3170"	CL-5317	.3445"	CL-53445	.3760"	CL-5376
Auto-Driver		CL-3500		CL-3504		CL-3506
Trim Tool	.500" OD	CL-5600	.500" OD	CL-5600	.500" OD	CL-5600
Trim Tool Pilot		CL-5620		CL-5622		CL-5624
Guide Brush		WCB-44		WCB-44		WCB-44

tech tips
from the techxperts™

The centering cone must fit the valve seat properly so using the correct size is essential. This is NOT a one-size-fits-all tool. If you have a cone that is too small for the seat it could slip through the opening. If you have one that's too large, the side of the combustion chamber could interfere or you won't have enough of the cone in the seat area for it to be stable and centered.



60° Seat Centering Cones

- Center firmly in the valve seat
- Cones feature a .625" ID
- Steel construction
- Use the Seat Centering Cones with the Master Tool Kits (above) for proper alignment of the reamer and guide bore

Description	Order No.
7 Piece Kit	CL-6500 ▼
Nominal Range	
1" 0.970"-0.730"	CL-6310 x
1¼" 1.230"-0.740"	CL-6308 x
1½" 1.475"-0.805"	CL-6306 x
1¾" 1.730"-0.860"	CL-6304 x
2" 1.950"-0.875"	CL-6302 x
2¼" 2.230"-1.000"	CL-6300 x
2½" 2.550"-1.875"	CL-6312 x

Bronze-Liners & Tooling

Carbide Sizing Balls

- Finished to .00008" roundness
- Within the 90 Rockwell range
- The finished ID of the Bronze-Liner will be .001" smaller than the ball used



Size	Order No.
6.0mm .2360"	CL-5236
.2370"	CL-5237
.2380"	CL-5238
7.0mm .2760"	CL-5276
.2770"	CL-5277
.2780"	CL-5278
5/16" .3125"	CL-53125
.3130"	CL-5313
.3140"	CL-5314

Size	Order No.
8.0mm .3150"	CL-5315
.3160"	CL-5316
.3170"	CL-5317
1 1/32" .3430"	CL-5343
.3435"	CL-53435
.3440"	CL-5344
.3445"	CL-53445
.3450"	CL-5345
.3460"	CL-5346
3/8" .3730"	CL-5373
.3740"	CL-5374
.3745"	CL-53745
.3750"	CL-5375
.3755"	CL-53755
.3760"	CL-5376

tech tips

from the techxperts™

Always be sure to hold your hand under the cylinder head to catch the carbide ball as it comes out of the guide.



Removal Tool

Remove bronze liners without damaging the bore using the driver tool at right

Description	Order No.
6.0mm	CL-7352
7.0mm	CL-7344
5/16"	CL-7310
8.0mm	CL-7320
1 1/32"	CL-7330
3/8"	CL-7340

Universal Driver Tool

- Fits all removal tools at left and is designed to work with your air hammer
- .401" ID • 4.75 OAL
- Order No. **CL-7333**



Small Hole Gauge Set

- See if rebuilding or replacing is needed by checking guide wear
- Check guide bosses for proper interference fit during replacement
- Check and maintain correct stem-to-guide ID clearance
- 4-piece set has combined range of .125" to .500"
- Order No. **SHG-4**



Thin-Wall .030" Bronze-Liners

- Outlast original guides
- Dimples promotes oil retention
- Rounded nose design makes installation quick and easy
- Stripe helps you identify rounded end
- Phosphor-bronze

Phosphor-bronze liners outlast original guides and are easy to replace

Stripe helps you quickly identify the round nose end

Rounded nose design makes installation fast and easy

Dimples inside promote oil retention

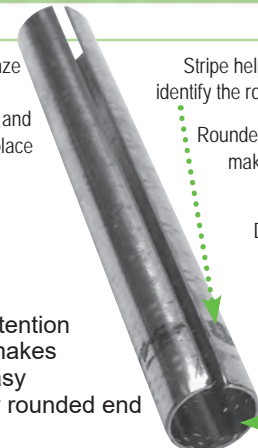

tech tips

from the techxperts™

NOTE: 5.0 & 5.5mm Guides do NOT interchange with competitors' guides. You MUST use our tooling with these guides.

Guide Size	Liner Size		Box of 16	Box of 100
	OD	Length	Order No.	Order No.
5.0mm	+ .030"	2.00"	CL-500	CL-500A
5.5mm	+ .030"	2.50"	CL-550	CL-550A
6.0mm	+ .030"	2.50"	CL-600	CL-600A
7.0mm	+ .030"	2.50"	CL-700	CL-700A
.312"	+ .030"	2.50"	CL-1220	CL-1220A
8.0mm	+ .030"	2.50"	CL-1420	CL-1420A
.343"	+ .030"	3.00"	CL-1640	CL-1640A
.375"	+ .030"	3.00"	CL-1830	CL-1830A
Override OD Bronze Liners				
.343" +.002"	+ .032"	2.50"	CL-1640-2	CL-1640-2A
.375" +.002"	+ .032"	3.00"	CL-1820-2	CL-1820-2A
.375" +.004"	+ .034"	3.00"	CL-1820-4	CL-1820-4A

Chamfer Tool & T-Wrench

Use these optional accessories to remove any burrs that may be created when trimming the liner to length

Description	Order No.
Chamfer Tool	CL-5800
T-Wrench	CL-5870

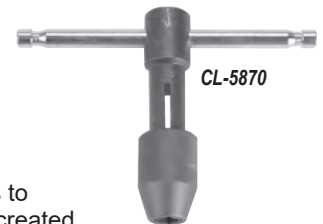

Mitutoyo

Split Ball Bore Gauge

- Dial gauge with large contact area
- Measures quickly & accurately to .0001" (.0025mm)
- Works in threaded or knurled guide IDs
- Range: .280" to .400"
- Easy to change contacts
- Includes molded plastic storage case
- Order No. **MVG-34**



premium grade

CYLINDER HEAD REBUILDING
CLEANING, ASSEMBLY & SAFETY
SHORT BLOCK REBUILDING
FLYWHEEL GRINDING
CRANKSHAFT/
TOOLING & SUPPLIES
MISCELLANEOUS TOOLS & SUPPLIES
BRAKE SERVICE TOOLING
MEASURING TOOLS
V-TWIN & METRIC HARD PARTS



"If any of our products aren't satisfactory, we want you to send it back. We have a no hassle return policy. Just send it back, freight pre-paid within 60 days and we'll exchange it, fix it or credit your account for the amount of the purchase."

- Kayla, Goodson Customer Service, 2 years of service

CYLINDER HEAD
REBUILDING

CLEANING,
ASSEMBLY & SAFETY

SHORT BLOCK
REBUILDING

CRANKSHAFT/
FLYWHEEL GRINDING

MISCELLANEOUS
TOOLS & SUPPLIES

BRAKE SERVICE
TOOLING

MEASURING
TOOLS

V-TWIN & METRIC
HARD PARTS

Valve Seal Puller

- .810" tool dia.
- Fits Multi-Valve Engines
- Lifts from the bottom of the seal
- Works within the confines of lifter bucket bores
- Fingers grip seal for fast, easy removal
- Works on most domestic and import vehicles
- New and improved seal puller with stronger 3 jaw pulling action

Description	Order No.
Valve Seal Puller	VSP-323
Replacement Shaft	VSP-323-4
Replacement O-Ring	VSP-323-5
Replacement Jaw Set (3 Pc.)	VSP-323-3
Replacement Jaw Sleeve	VSP-323-1
Black Split Sleeve	VSP-323-2

Parts are interchangeable with VSP-320



3 Finger Jaw
Grips Seals
Firmly!



Universal Seal Pliers

- Works on OHC and in-line engines with recessed springs
- Long, serrated jaws reach into confined areas and grip seals firmly
- Heat-treated steel with easy-grip handles
- Order No. VSP-823



sized for
diesel

Intake & Exhaust Valve Stem Seals for 24 Valve, 7mm Cummins Diesel

- Fit 7mm valve stems
- OD measures .511"
- Sold in packs of 12

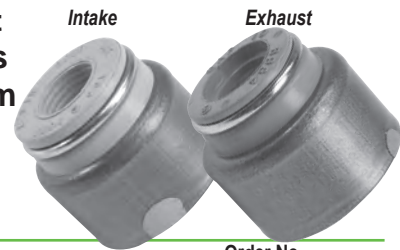

Application	Order No.
Intake	CVS-59i
Exhaust	CVS-59E



QualCast

Goodson now offers the full line of QualCast Products.

Whatever you're looking for, you can find it online at www.goodson.com!

- Valves
- Valve Guides
- Valve Spring Inserts
- Valve Lifters
- Rocker Components
- Push Rods
- And a whole lot more!
- Valve Seat Inserts
- Valve Springs
- Valve Keepers (cotters, keys)
- Valve Stem Seals
- Injector Components
- Freeze Plugs

You'll find products for High Performance, Light Duty, Standard Duty and Heavy Duty. Products ship directly from QualCast's Nashville location to your door. Visit the QualCast section on the Goodson website today or Call 1-800-533-8010.

Height Indicator

- Measure compressed spring height when testing pressure
- Ideal for high performance and checking identical springs
- For Rimac® and other spring testers
- Height Scale displays inches and metric
- Includes Dial Indicator, and Mounting Kit (additional dial indicators on page 127)
- Order No. VST-25

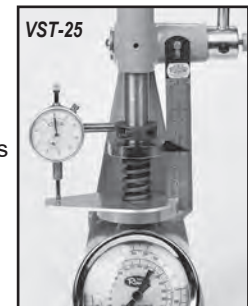

Minnesota Fast Freeze

- Instantly chills seats & guides to -50°F (-45.5°C)
- Creates interference fit with heated aluminum heads
- Finish seat and guide work faster than ever
- Aerosol*
- Use on tight bushings, pins, shafts, etc.
- 10 oz. can

Description	Order No.
Minnesota Fast Freeze	MFF-8

*Hazardous Goods Fees Apply When Shipped by Air

Valve Spring Testing

Rimac® Valve Spring Testers

new

Rimac® Valve Spring Testers

- Specifically designed for quick, easy testing of multiple valve springs
- High-torque, lever-actuated compression is key to repeatable precision
- The vertical design ensures stability on the workbench
- Ideal for use in the shop, but portable enough to take to the racetrack
- Calibrated spring set includes two springs with different ranges that can be combined for a range of 10 to 640 lbs.

Description	Order No.
0-500 lb. Tester (reads in 5 lb. increments)	VST-69
0 to 1000 lb. Tester (reads in 2 lb. increments)	VST-70
Calibrated Test Spring Set (2 pc.set)	VST-SPRINGS

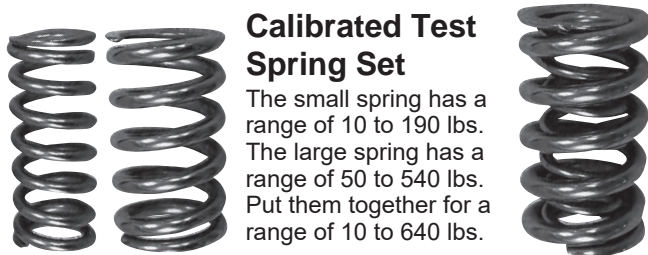

Calibrated Test Spring Set

The small spring has a range of 10 to 190 lbs. The large spring has a range of 50 to 540 lbs. Put them together for a range of 10 to 640 lbs.

made in America



VST-69

Positive stop for checking repeatability

Adjustable multi-position lever

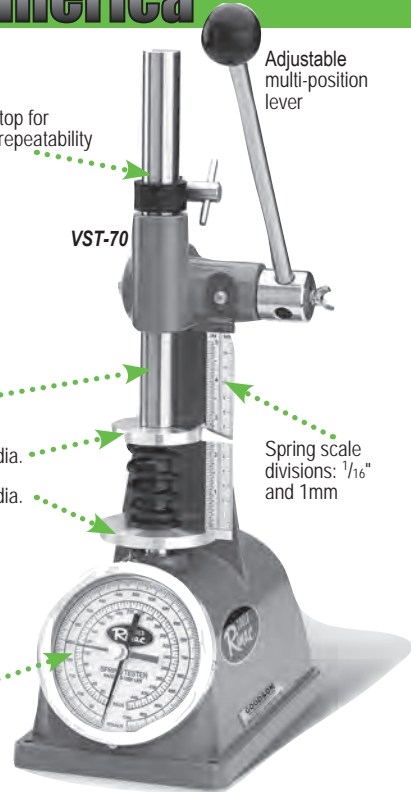

VST-70

Ram travels 4⁵/₈"

Upper Platform measures 2¹/₄" dia.

Lower Platform measures 3³/₄" dia.

Spring scale divisions: 1/16" and 1mm

Easy to read dial shows both pounds and kilograms

CYLINDER HEAD
REBUILDING

CLEANING,
ASSEMBLY & SAFETY

SHORT BLOCK
REBUILDING

CRANKSHAFT/
FLYWHEEL GRINDING

MISCELLANEOUS
TOOLS & SUPPLIES

BRAKE SERVICE
TOOLING

MEASURING
TOOLS

V-TWIN & METRIC
HARD PARTS



Easy-to-use Travel Stop with adjustable set screws lets you set an exact position, allowing repeated testing at a desired height. Two set screws allow you to adjust for installed spring height and max lift (near coil bind).

Arbor style handle makes compressing springs fast and easy

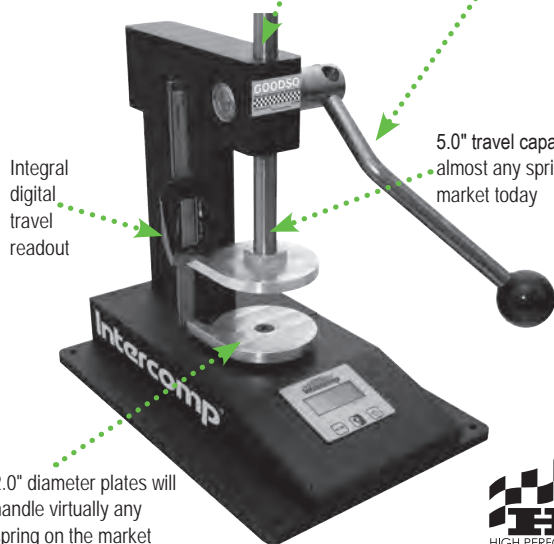

Integral digital travel readout

5.0" travel capacity will fit almost any spring on the market today

2.0" diameter plates will handle virtually any spring on the market



Protect Your Valuable Valve Spring Tester with a Machine Cover!

Fits Machine	Order No.
VST-2000 Spring Tester	GMC-VST
Rimac Spring Tester	GMC-RIMAC

More Machine Covers on page 25

Intercomp® Digital Arbor Valve Spring Tester

- 1,500 lb / 680.4 kg load cell in 1 lb. increments
- Force units switchable from pounds to kilograms
- Billet 6061 T-6 Aluminum construction
- Digital travel readout at .001"/inch or .01/mm
- 5" travel capacity • 2.0" diameter spring pads
- Easy to read backlit screen
- Operates on 9V battery (included)
- Adjustable stop to repeatedly check springs at the same heights
- Order No. VST-2000

For routine calibration of spring testers, return tester to Goodson. Call for details, 1-800-533-8010.

... another satisfied customer

"Everyone at Goodson has been and is always great help! Quality products at great prices. A must to build high quality engines"

- Wayne Brown, Brunswick, GA, Goodson customer since 2023



CYLINDER HEAD REBUILDING



Pneumatic Head:
Adjustable to 25° in either direction for canted valves



Head Support:
Table adjusts 45° to the front and 30° to the rear

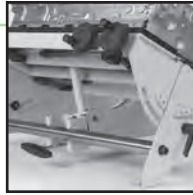

Positive Stops: Adjusts front and rear angles

CLEANING, ASSEMBLY & SAFETY



Speed Knobs:
Allows quick positioning of workpiece



Foot Pedal:
Easy, hands-free operation



Quick Release Knob:
Allows fast positioning to opposite cam bank

SHORT BLOCK REBUILDING

CRANKSHAFT/ FLYWHEEL GRINDING

MISCELLANEOUS TOOLS & SUPPLIES

BRAKE SERVICE TOOLING

MEASURING TOOLS

V-TWIN & METRIC HARD PARTS

Goodson exclusive

Slide Hammer:
A quick tap loosens keepers for fast removal



To watch how-to set-up and use the Pneumatic Valve Spring Bench, scan the code below with your smart phone or other smart device.



Pneumatic Valve Spring Press

- Pneumatic valve support holds valve closed as you compress the spring
- Produces 432 lbs. of force at 100 PSI
- Adjustable stainless steel plate won't damage the head
- 28mm Valve Spring Adaptor (**CF-502**) is standard with unit (other sizes are available) • Measures 28"L x 24"W x 26"H
- Ideal for use on heads with recessed springs • For aluminum and cast iron heads
- Ships fully assembled • Replacement Parts Available
- Order No. **PSB-5000**

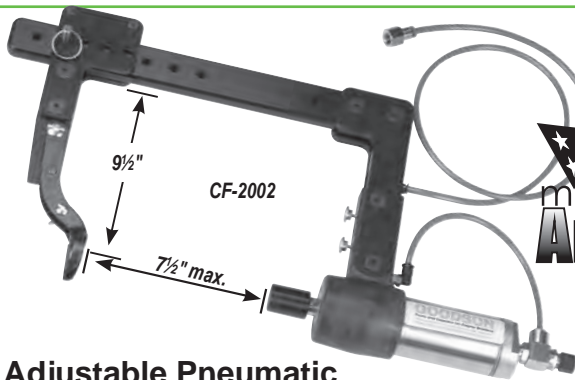

CF-2002

9 1/2"

7 1/2" max.

made in America

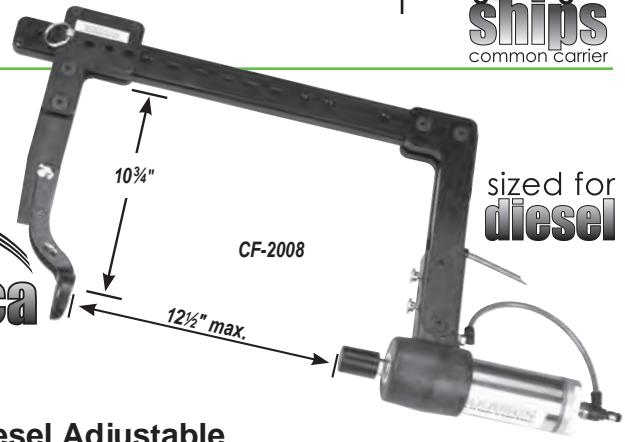

CF-2008

10 3/4"

12 1/2" max.

sized for diesel

Adjustable Pneumatic Valve Spring Compressor

- Develops up to 325 lbs. of force with 130 PSI
- For springs from 3/4" to 1 3/4" dia.
- CNC-machined 6061 T6 aircraft-quality aluminum frame is adjustable in 1/4" increments
- Includes adjustable jaws (**CF-44**)
- Stainless steel cylinder with viton grade seals
- 2" cylinder travel • Fingertip controls • Full 1 year warranty

Description	Order No.
Valve Spring Compressor	CF-2002
Replacement Parts and Accessories	
Valve Spring Adaptor Jaw Set	CF-44
1/4" Green Air Line (lin. ft.)	CF-2001-AL
Air Control Needle Valve	CF-2001-NV
Intake / Exhaust Cartridge	CF-2003-C
Air Cylinder 2" Travel	CF-2001-AC
1/8" NPT L-Fitting	CF-2003-L

Diesel Adjustable Pneumatic Valve Spring Compressor

- Develops up to 325 lbs. of force with 130 PSI
- For springs from 3/4" to 1 3/4" dia.
- CNC-machined 6061 T6 aircraft-quality aluminum frame is adjustable in 1/4" increments
- Includes adjustable jaws (**CF-44**)
- Stainless steel cylinder with viton grade seals
- 2" cylinder travel • Fingertip controls • Full 1 year warranty

Description	Order No.
Valve Spring Compressor	CF-2008
Replacement Parts and Accessories	
Valve Spring Adaptor Jaw Set	CF-44
1/4" Green Air Line (lin. ft.)	CF-2001-AL
Air Control Needle Valve	CF-2001-NV
Intake / Exhaust Cartridge	CF-2003-C
Air Cylinder 2" Travel	CF-2001-AC
1/8" NPT L-Fitting	CF-2003-L

Valve Spring Compressors



**Goodson
exclusive**

Locking Arm:
Holds the C-frame
securely in position
at the desired angle



Lock Collar:
Can be used to stop
vertical travel or to hold
spring compressed
while assembling
keepers

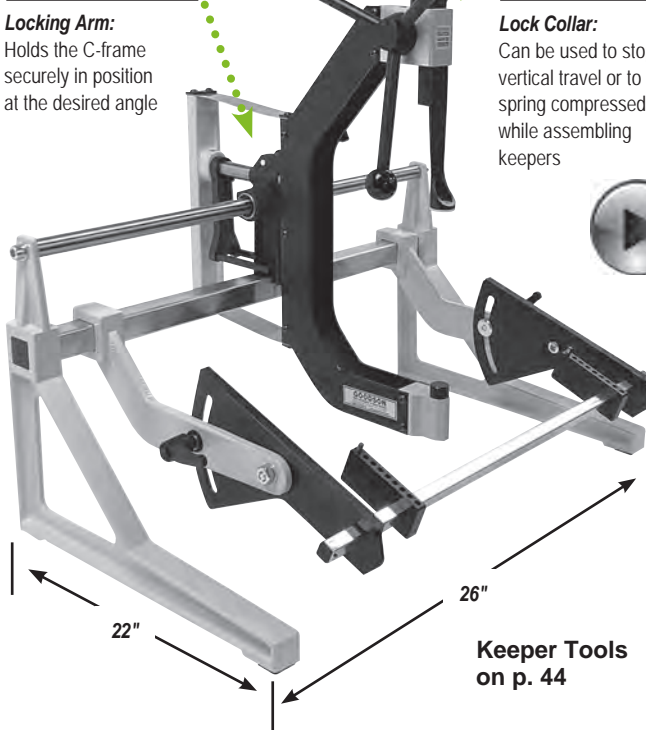

**Keeper Tools
on p. 44**

Manual Valve Spring Bench

- Remove and install valve springs on heads with recessed springs
- Creates 550 lbs. force with 45 lbs. exertion
- Includes 28mm diameter spring adaptor (**CF-502**), other size spring adaptors also available (see chart below)
- Frame tilts up to 25° in either direction for canted valves
- Full cylinder head support is adjustable from 0 to 45°
- Integral slide hammer easily releases stuck keepers
- Replacement parts available
- Order No. **CF-500**



To watch how-to use the Manual Valve Spring Bench, scan the code at right with the camera on your smart phone or other smart device.



Spring Adaptors

- Fit both manual (**CF-500**) and pneumatic (**PSB-5000**) spring benches
- 1/2" pin diameter
- Solid steel construction with replaceable nylon wear insert



OD	Reach	Adaptor	Insert
18mm	4 1/2"	CF-518	CF-518-1
23mm	4 1/2"	CF-501	CF-501-1
28mm	3 1/2"	CF-502	CF-502-1
35mm	2 1/2"	CF-503	insert not required



**made in
America**

Dual Stage 1000 Lb. Pneumatic Valve Spring Compressor

- Lightweight — built of 6061 / 7075 T-6 Aluminum
- 1 1/2" Screw Adjustment — 7" to 8 1/2" Throat
- Certified to 1000 lbs of force
- Dual stage air pump develops up to 1000 lbs. of force on as little as 70 psi air supply — **Do NOT exceed 120 psi**
- Includes 1.600" ID Jaw adaptor, 1.740" ID jaw sold separately

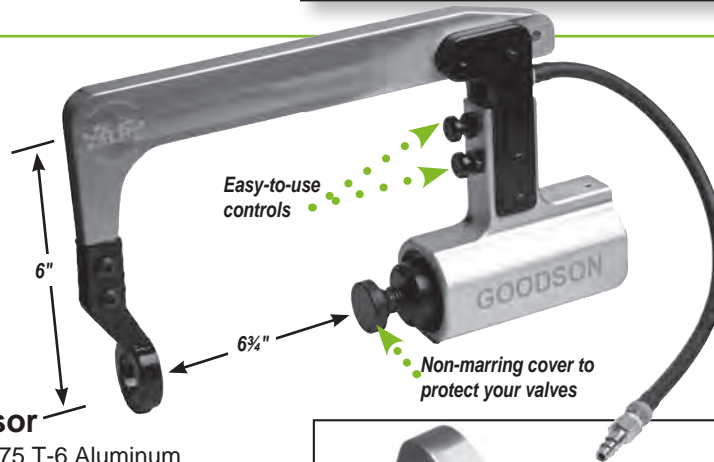

**Easy-to-use
controls**

**Non-marring cover to
protect your valves**



Description	Order No
Spring Compressor with 1.600" ID Jaw	GSC-1000
Replacement Standard Jaw, 1.600" ID	GSC-3002
Adaptor Jaw, 1.740" ID	GSC-3003
LS1 Jaw Adaptor (1.740 OD) use with CF-3002	GSC-3000-LS1
Rebuild Seal Kit (with Intake Button Return Spring)	GSC-3000SK
Replacement Intake Button Return Spring	GSC-3004
Intake Trigger Assembly	GSC-20004A
Exhaust Trigger Assembly	GSC-20004B
Delrin Pressure Cap (included)	B-10005C

NOT interchangeable with our CF-3000B Spring Compressor

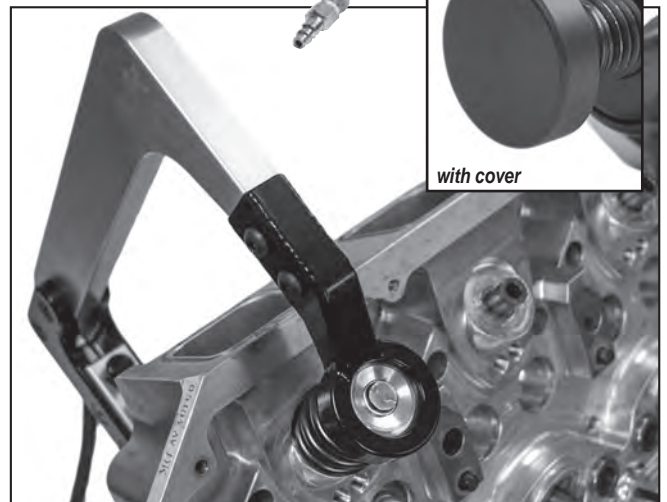

CYLINDER HEAD REBUILDING
CLEANING, ASSEMBLY & SAFETY
SHORT BLOCK REBUILDING
CRANKSHAFT/FLYWHEEL GRINDING
MISCELLANEOUS TOOLS & SUPPLIES
BRAKE SERVICE TOOLING
MEASURING TOOLS
V-TWIN & METRIC HARD PARTS



"You'll always get fast, reliable service from Goodson, even on international orders. We'll do whatever it takes to make sure you get your shop supplies as quickly and easily as possible - anywhere in the world."

- Paige, Goodson Customer Service, 6 years of service

CYLINDER HEAD
REBUILDING

Manual Valve Spring Compressor

- Weighs only 6 lbs
- High leverage allows for easy, one-hand operation
- Covers a range from 10"H to 8"D
- Works with most L-head and valve-in-head engines
- Fits truck & tractor engines
- Jaws adjust for different spring sizes

Description	Order No.
Spring Compressor	CF-140
Replacement Jaw Set	CF-44
HD Replacement Jaw Set	CF-44HD

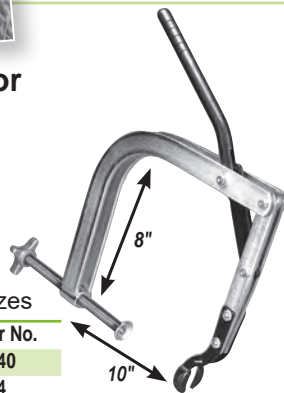

CLEANING,
ASSEMBLY & SAFETY



Manual Valve Spring Compressors

- Handle valve springs from a range of applications
- Welded, gusseted all-steel construction takes plenty of abuse
- Plenty of leverage to compress valve springs
- Order No. **CF-1500**

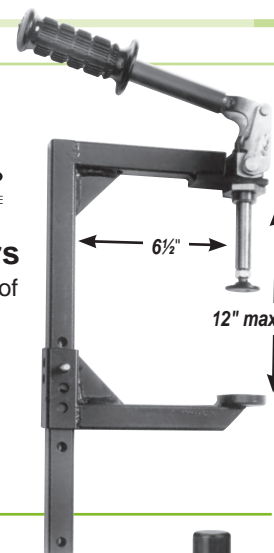

SHORT BLOCK
REBUILDING

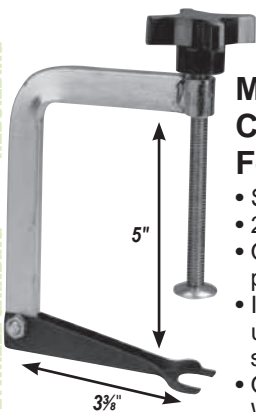

Manual Valve Spring Compressor For Small Engines

- Steel construction
- 20lb. max. spring pressure
- Once you lock the compressor in position, your hands are free to work
- Includes 2 jaw sets - small, for springs up to 7/8" (22.2mm) and large, for springs up to 1 1/16" 27.0mm)
- Order No. **CF-600**
- While Supplies Last

small engine
powersports

CRANKSHAFT/
FLYWHEEL GRINDING

Valve Spring Compressor Adaptor

- Fits seat and guide machines or drill press
- Puts collet or drill press chuck behind adaptor
- Allows more room to remove or re-install valve keepers and associated components
- Fits 1/2" collet or Jacobs chuck (not included)

OD (mm)	Reach (mm)	Order No.
3/4" (19.1)	3 3/4" (95.3)	CF-6
1 3/16" (20.6)	3 3/4" (95.3)	CF-8
1" (25.4)	3 3/4" (95.3)	CF-10
1 1/4" (31.7)	3 3/4" (95.3)	CF-12
1 1/2" (38.1)	3 3/4" (95.3)	CF-15



MISCELLANEOUS
TOOLS & SUPPLIES



Keeper Installation Tools

- Spring-loaded plunger
- For single & multi-groove keepers
- Reaches keeper grooves located farther from the valve tip • Ideal for use with **CF-500** (p. 43) and **PSB-5000** (p. 42)



Size	Order No.
5mm / .2031"	VKI-5
6mm / .2344"	VKI-6
7mm / .2812"	VKI-7
8mm / .3125"	VKI-8
Replacement Rubber Sleeve	VKI-56

BRAKE SERVICE
TOOLING

Adaptors for Deeply Recessed Springs

- Open top design gives easy access to keepers
- Durable, non-marring material
- Fit on Split-Jaw Spring Adaptors such as our **CF-44** (below)



Description	OD	Height	Order No.
Small Metal Adaptor	26mm	4" (101.6mm)	CF-32
Medium Nylon Adaptor	27mm	3" (76.2mm)	CF-24-G
Large Nylon Adaptor	32mm	3" (76.2mm)	CF-25-G

MEASURING
TOOLS

One of the handiest keeper tools you'll ever find!

Keeper Magnet

- 6 5/16" long holder fits easily into deep bores
- Powerful .170" diameter earth magnet holds keepers securely when removing or installing
- Order No. **VKM-17**

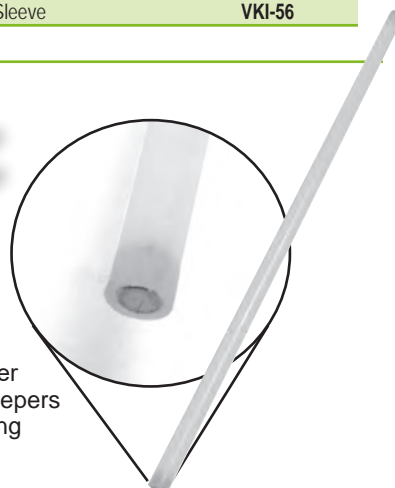

V-TWIN & METRIC
HARD PARTS



Valve Spring Adaptor Jaws

- Fit frames with double locking screws to secure jaws such as Goodson **CF-2002**, **CF-2008** and **CF-140**
- Heavy duty jaws are non-adjustable (has a 1 5/8" max spring diameter)

Description	Order No.
Standard Duty 1.000"-1.875" (25.4-47.6mm) Range	CF-44
Heavy Duty (non-adjustable)	CF-44HD

Air Powered Grinder
uses standard shop air

DESIGNED BY AN ENGINE BUILDER FOR ENGINE BUILDERS!

Bucket Lifter Grinder Assembly with FREE Grinder

- Machine just the bucket lifter!
- Fast and accurate
- Save time — measure once, then remove the material from inside the Bucket Lifter instead of machining the stem height and finding the right VAD thickness or grinding the seat to meet your specs
- Micrometer feed shows how much material is being removed
- Confirm with dial indicator and bridge (included)
- Use right at your assembly station
- Works with most Bucket Style Lifters, including those with VADs
- Complete Assembly includes Air Driver, CBN Cutter, Micrometer Feed Body, Dial Indicator and Indicator Base
- **US Patent Number US 10456887**

Description	Order No.
Complete Bucket Lifter Grinder Assembly	BLG-1000
Replacement CBN Cutter	BLG-1001
Replacement Dial Indicator	EDI-1
CBN Dressing Stick 1/2" x 1/2" x 6"	DS-CBN

Micrometer Feed shows
how much material you are
removing

CBN Cutter makes
quick work of
virtually any
bucket lifter

Use the Dial Indicator and Base
to measure the valve contact point.
Once determined, remove necessary
material to set lash.

 **video**
available

View our Tech Lab Tuesday
video to see how easily you can
adjust valve lash with the Bucket
Lifter Grinder. Scan the code
at left with the camera on your
smart phone or other smart
device for instant access.



CYLINDER HEAD
REBUILDING

CLEANING,
ASSEMBLY & SAFETY

SHORT BLOCK
REBUILDING

CRANKSHAFT/
FLYWHEEL GRINDING

MISCELLANEOUS
TOOLS & SUPPLIES

BRAKE SERVICE
TOOLS

MEASURING
TOOLS

V-TWIN & METRIC
HARD PARTS

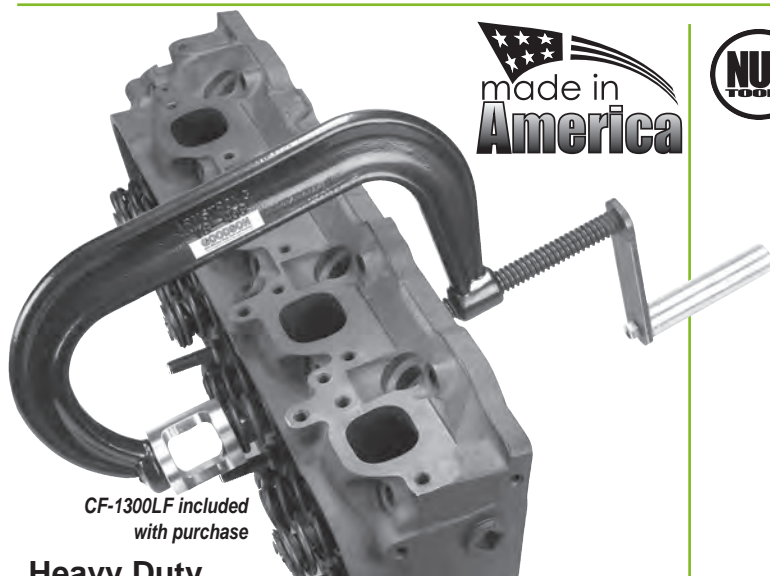

CF-1300LF included
with purchase

Heavy Duty Manual Valve Spring Compressor

- Drop forged steel frame
- Open receiver design allows for quick access to keepers
- Accommodates springs up to 1 3/4" diameter
- 8 1/2" throat • 6" deep
- Compresses springs up to 1000 pounds

Description	Order No.
Manual Valve Spring Compressor	CF-1300
Small Receiver (OD: 1.625", ID: 1", Height: 2.156")	CF-1300SF
Large Receiver (OD: 2.0", ID: 1.197", Height: 2.25")	CF-1300LF

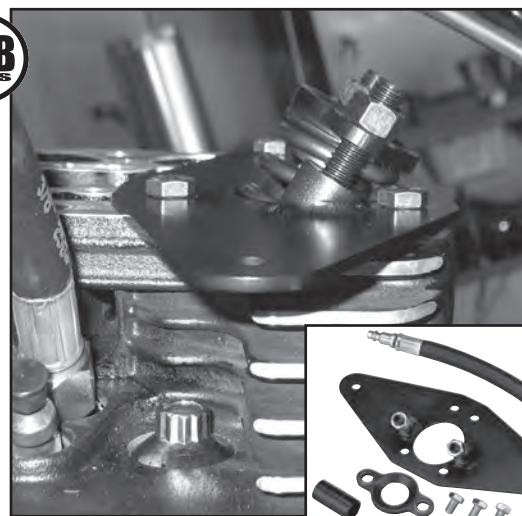

made in
America



V-Twin On-the-Engine Valve Spring Compressor

Replace broken valve springs, install high performance valve springs, remove and replace valve guide seals all without disassembling the bike. Just remove the gas tank and get to work. Use on Sportster, Evolution, Twin-Cam and most aftermarket V-Twins. Kit includes valve spring compressor, adaptor for compressing beehive springs, valve seal driver/installer and head pressurizing hose. Order No. **CF-HDIF**

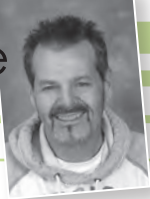
made in
America



"We work hard to get the right products in the right boxes and ship them to the right address every single time."

- Shawn, Goodson Shipping, 6 years of service

CYLINDER HEAD
REBUILDING

CLEANING,
ASSEMBLY & SAFETY

SHORT BLOCK
REBUILDING

CRANKSHAFT/
FLYWHEEL GRINDING

MISCELLANEOUS
TOOLS & SUPPLIES

BRAKE SERVICE
TOOLING

MEASURING
TOOLS

V-TWIN & METRIC
HARD PARTS

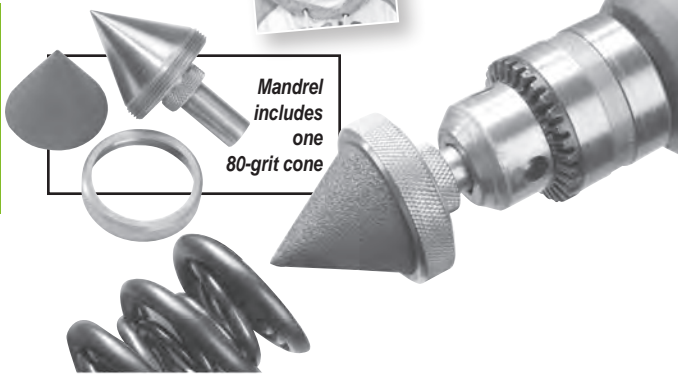

Mandrel
includes
one
80-grit cone

Small Chamfering Cones & Mandrels Make Deburring and Chamfering Easy In Tight Spaces

These mandrels are available in two diameters – 3/4" and 1 1/2" diameters with a 1/2" shank to fit most portable drills. The small diameter fits easily into tight spaces such as Beehive Valve Springs (see page 132) or bolt holes. The mandrel is designed to support a 60° abrasive cone which is held securely by the retaining ring. One 80-grit cone is included with initial purchase.

Description	Order No.
3/4" Dia. Mandrel	CC-34
3/4" Dia. Abrasive Cones 80 grit	CC-35
120 grit	CC-36
1 1/2" Dia. Mandrel	CC-60
1 1/2" Dia. Abrasive Cones 80 grit	CC-61
120 grit	CC-62

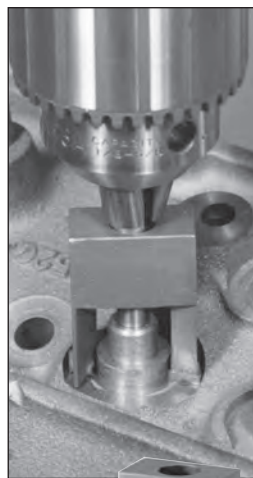

3-D Fast Cut™
Adjustable Spring Pad
Cutters on page 12



Valve Spring Seat Cutters

- Resize valve spring seats to maintain spring-to-valve concentricity or use to enlarge seats for over-size dual springs
- Requires special pilot – see chart below

Carbide Tipped Cutter Bodies
(use VP pilots below)

OD	ID	Order No.
1.320"	.630"	VSS-1320
1.350"	.625"	VSS-1350
1.500"	.625"	VSS-1500
1.550"	.625"	VSS-1550
1.625"	.625"	VSS-1625
1.680"	.750"	VSS-1680HD
1.750"	.625"	VSS-1750

Hardened & Ground Pilots

Guide ID	Order No.
.275"	VP-7MM
.312"	VP-312
.343"	VP-343
.375"	VP-375

tech tips

from the techxperts™

You must use these pilots with the VSS and VSC cutters. The flat sides are necessary for a proper fit.

Universal Gel Lube

- Sprays on as a liquid and forms into a gel within seconds
- Penetrating formula blends freely with motor oil
- Multiple uses, including cams, lifters, rocker arms, bearings, pistons/wrist pins, cylinders, etc.
- Provides lubrication for engines subjected to prolonged storage before initial start-up
- Aerosol*
- Order No. **GL-8U**



*Hazardous Goods Fees Will Apply if Shipped By Air



8 Piece Valve Train Checking Spring Set

- 1.250" OD
- Spring Steel construction
- Essential for high-performance engine building and engine blueprinting
- Maintain a positive valve train position while checking valve to piston clearance
- Order No. **VTS-8**



Buy the
Kit and
SAVE!

Dial Indicated Valve Stem Height Gauges

- 5 sizes to choose from
- Small diameter extended measuring body allows extra height for dial indicator clearance
- Use with our large-faced Dial Indicator to check valve tip height



Description	Order No.	Incl.
Valve Stem Height Gauge Kit w/Stand	VSH-KIT	▼
Dial Indicator (2" travel, .001" graduations)	MDI-2	x
Dial Indicator (1" travel, .001" graduations)	EDI-1	
Measuring Bodies	OD ID OAL	
	.750" .625" 3.830"	VSH-205 x
	.900" .770" 2.840"	VSH-203 x
	.900" .770" 3.840"	VSH-204 x
	1.060" .812" 2.840"	VSH-201 x
	1.250" 1.090" 3.300"	VSH-202 x
5-Post Tool Stand	TS-5	x
1" Checking Standard	MCS-1	

More dial indicators on page 127

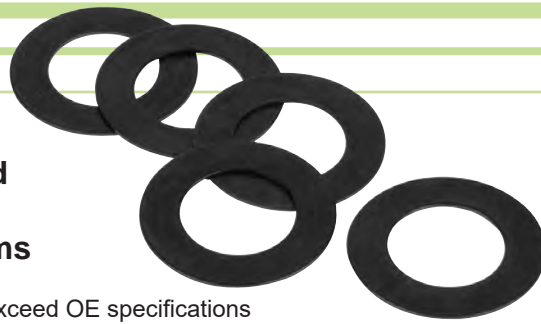

Non-Serrated Valve Spring Booster Shims

- Won't compress
 - Shims meet or exceed OE specifications
 - Maintain pressure and protect head from spring abrasion
 - Made of prime quality cold rolled steel
 - Support valve springs better than serrated shims
 - Won't damage spring pad area on aluminum heads or cause lateral loads or harmonics
- Special Orders are available.**

Size		50 count High Performance			100 count		
OD	ID	.060"	.030"	.015"	.060"	.030"	.015"
1.000"	0.688"				A-101	B-101	C-101
	0.765"			A-104	B-104		
1.100"	0.719"					B-106	
1.218"	0.875"				A-105	B-105	
1.250"	0.625"	A-107-HP	B-107-HP	C-107-HP	A-107	B-107	C-107
	0.812"	A-203-HP	B-203-HP	C-203-HP	A-203	B-203	C-203
	0.875"				A-201	B-201	
1.360"	1.000"	A-102-HP	B-102-HP	C-102-HP	A-102	B-102	
1.375"	0.765"	A-301-HP	B-301-HP	C-301-HP		B-301	
1.438"	0.645"	A-306-HP	B-306-HP	C-306-HP			
1.439"	0.765"	A-305-HP	B-305-HP	C-305-HP			
1.480"	0.703"	A-303-HP	B-303-HP	C-303-HP	A-303	B-303	
1.500"	0.645"	A-306S-HP	B-306S-HP	C-306S-HP			
	1.031"	A-103-HP	B-103-HP	C-103-HP	A-103	B-103	
1.634"	0.643"	A-601-HP	B-601-HP	C-601-HP			



Magnetic Head Bolt Washer & Valve Spring Shim Removal Tools

- Hollow design allows easy access over studs or head castings
- Powerful earth magnets grab firmly, letting you lift the washer or shim easily

Description	Order No.	Incl.		
Magnetic Remover Set	MWR-SET	▼		
Washer Removers	ID	OD		
	0.250"	0.625"	MWR-14	x
	0.500"	0.865"	MWR-12	x
	0.450"	0.812"	MWR-716	x
Shim Remover	0.708"	1.355"	MVSR-2	x



View "CCing Heads — How To Measure Your Combustion Chamber Volume." Scan the code at right with the camera on your smart phone or other smart device for quick access.



100cc Glass Buret allows use with alcohol or solvent with high-visibility red markings

Clamp gives you ability to fully adjust the height of the buret in relation to your cylinder head

Cylinder Head CC-ing Equipment

- Use glass buret with alcohol or solvent
- Positive on/off fluid control valve
- Clear acrylic plate lets you see when the combustion chamber is full
- Mix Measuring Concentrate with water to make 1 gallon

Description	Order No.	Incl.
CC-Measurement Kit	CCB-KIT	▼
100cc Glass Buret	CCB-100	x
5" x 5" x 3/8" Acrylic Plate	GCB-3	x
Buret Cleaning Brush - 35/2" OAL	GCB-BRUSH	x
Buret Stand	GCB-1	x
Buret Clamp	GCB-2	x
Funnel - 2 oz. Capacity	CCB-FUNNEL	x
Blue Measuring Liquid Concentrate (Yields 1 Gal.)	GCB-LIQUID	
4" Precision Cylinder Head Level	LEV-4	
Replacement Vial for 4" level	VGL-101	
100cc Graduated Glass Beaker	GC-100	
Universal Cylinder Head Holders (pair)	HH-200	

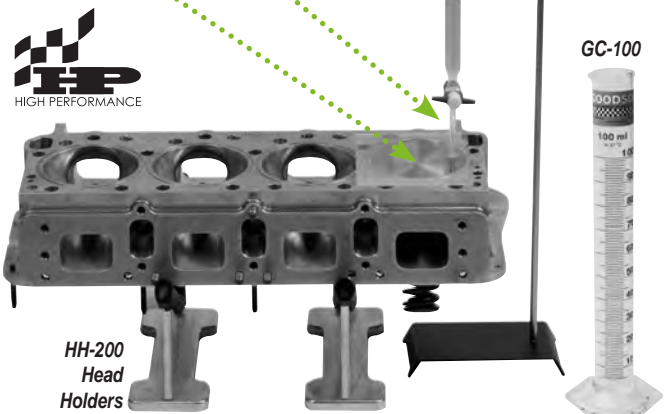

CYLINDER HEAD REBUILDING
CLEANING, ASSEMBLY & SAFETY
SHORT BLOCK REBUILDING
FLYWHEEL GRINDING
CRANKSHAFT/ TOOLS & SUPPLIES
MISCELLANEOUS
BRAKE SERVICE
MEASURING TOOLS
V-TWIN & METRIC HARD PARTS



"Goodson accepts major credit cards, debit cards, bank drafts and personal checks. Call us for more information."
- Bev, Goodson Accounting Manager - 41 years of service

resharpening available

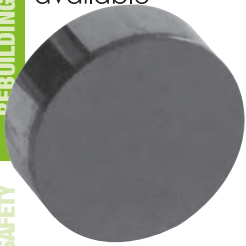

PCD Inserts for Aluminum

- A must for shops committed to meeting today's strict surface finish requirements
- Fits machines with 3/8" & 1/2" CBN holder
- 1/2" diameter inserts require shim*
- Use with Resurfacing Spray (HPS-16) for best results (below)

Titanium-Nitride Coated			Goodson	Radiac
Dia.	Thick.	Sided	Order No.	Order No.
3/8"	1/8"	Single	PCDS-375	-----
	1/8"	Single	GPCD-375	-----
1/2"	1/8"	Single	-----	2379264*
	1/8"	Single	GPCD-500*	-----
1/2"	3/16"	Single	PCDS-500	-----
1/2"	3/16"	Single	-----	2379265
1/2"	3/16"	Single w/screw hole	-----	2X6145
1/16"	Thick Carbide Shim*		CBN-500SHIM	-----

CBN Cutter Inserts for Cast Iron

- Faster and cleaner than segments and wheels



Uncoated			Goodson	Uncoated	Radiac
Dia.	Thick.	Sided	Order No.	Order No.	Order No.
3/8"	1/8"	Single	GCBN-375	-----	-----
	1/8"	Single	GCBN-500*	-----	-----
Titanium-Nitride Coated					
1/2"	1/8"	Double	CBN-500D*	-----	2X5299*
	3/16"	Single	CBN-500S	-----	2359233
	3/16"	Solid	-----	-----	2359234
	3/16"	Single Sided with Screw Hole	-----	-----	2X6144
3/8"	1/8"	Special Edge Prep for Diesel	-----	-----	2379268
	1/8"	Single	-----	-----	-----
3/8"	1/8"	Double	CBN-375D	-----	-----
	1/8"	Single	CBN-375S	-----	-----
Sharp Uncoated					
3/8"	1/8"	Single	CBNS-38	-----	-----
1/2"	3/16"	Single	CBNS-12	-----	-----
1/16"	Thick Carbide Shim*		CBN-500SHIM	-----	-----

resharpening available

CBN Super Abrasive For Cast Iron Diesel Heads

- Designed for cast diesel heads with hardened pre-cups • Won't chip
- Fits all overhead surfacers with 1/2" diameter insert capacity
- Will NOT work on standard cast heads

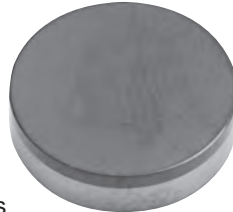

Cut using the dull finished side

Standard Grade Cutters			
Dia.	Thick.	Sides	Order No.
3/8"	1/8"	Single	GCBN-D375
1/2"	1/8"	Single	GCBN-D500
Premium Grade Cutters			
Dia.	Thick.	Sides	Order No.
1/2"	1/8"	Single	DRD-500
1/16"	Thick Carbide Shim		CBN-500SHIM

*NOTE: A 1/16" thick carbide shim must be used on DCM machines

Measure here for replacement vial

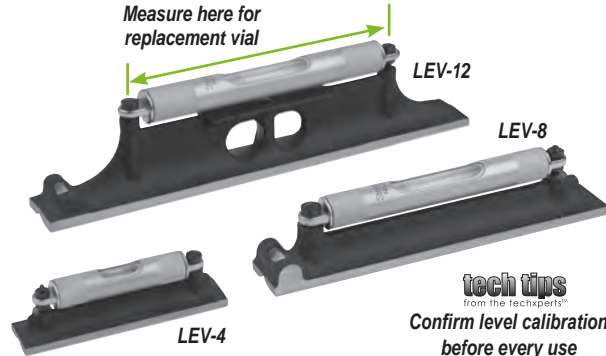

Starrett Precision Levels & Vials

- Graduated vials with satin-chromed, brass protective covers that rotate to close tightly
- Base castings are seasoned, then precision machined and finished on a bearing surface • Replaceable vials
- Adjustable for precise calibration
- 1 division equals .0005" per inch
- Fits pilots from 6mm to .437"
- Use replacement vial to right of level for correct fit

tech tips
from the techexperts™
Confirm level calibration before every use



VGL-100
(use with your pilot or find on page 3)

Description	Order No.	Replacement Vial
4" Valve Guide Level (3" vial)	VGL-100	VGL-101
4" Level (3" vial - nominal)	LEV-4	VGL-101
8" Level (6" vial - nominal)	LEV-8	LEV-8-1
12" Level (8" vial - nominal)	LEV-12	LEV-12-1

See goodson.com for level calibration instructions

High Performance Resurfacing Fluid

- Prolongs cutter life
- Enhances surface finish
- Refreshing scent



Description	Order No.
11 oz. Aerosol*	HPS-16
4 oz. Bottle	HPS-4

* Hazardous Goods Fees Apply When Shipped By Air

resharpening available



Tool Bits For Van Norman 530, 570 Rotary Broaches

- Can be resharpened
- Order No. VN-65C

Enlarged for clarity

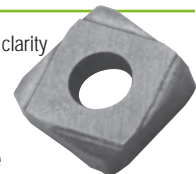

Carbide Cutter Replacement Tips For Storm Vulcan Broach Style Surfacer

- Fits Storm Mill 85, 85B, 85BE, 85C, 85N and 280
- Order No. SV-85BE



Cylinder Head Resurfacing

Abrasive Industrial Supplies

Need a Different Size or Grit or Material?

We can make the size you need. Specify grit, grain and size and we'll take it from there. Call 1-800-533-8010 for info!

Cylinder Head Resurfacing Belts

A belt has three important parts: abrasive, bond and backing. Goodson belts are made for top performance and long life. Our belts also feature a unique splice that permits use in both directions for even longer wear; when worn one way, turn belt around to resurface more heads.

Abrasive: Match the abrasive to the workpiece (aluminum, cast iron or steel) and to your machine for the longest belt life.



Selection Guide: which abrasive works best on what materials...

ALUMINUM	CAST IRON	STEEL	Zirconia-Alumina (40g)
			Silicon-Carbide (40g)
			Silicon-Carbide (80g)

Bond: Double-layer, heat-resistant resin holds abrasive firmly. Bond is so strong that grains wear out instead of loosening.

Resin Backing: Waterproof, poly-back belt won't tear or fray. It's the toughest backing of any resurfacing belt.

See list of machines and belt sizes below to determine which belt(s) you need.

Silicon-Carbide 40-grit:

- Good-quality • Black
- Primarily for cast iron but can resurface aluminum if extra care is used
- Down-pressure optional

Silicon-Carbide 60-grit:

- Good-quality • Black
- Primarily for cast iron but can resurface aluminum if extra care is used
- Down-pressure optional

Silicon-Carbide 80-grit:

- Good-quality • Black
- Designed especially to resurface aluminum
- Down-pressure not recommended

Zirconia-Alumina 40-grit:

- Better-quality
- Blue
- Grains fracture under pressure to stay sharp
- For cast iron or steel
- Down-pressure recommended

Zirconia Alumina With Grind Aid - 40-grit:

- Premium-quality belt with pre-applied Grind Aid • Blue/Green
- Excels on severe applications
- Grains fracture under pressure to stay sharp
- For stainless steel, alloy
- Down-pressure required

Belts with * are made to order. Please allow 3 to 5 working days for delivery.



Belt Size	Order No.	Order No.	Order No.	Order No.	Order No.
10" x 87"	SGS-10-87	SGS-10-87-60*	SGA-10-87*	SGB-10-87*	SGZ-10-87*
10" x 103"	SGS-10-103	SGS-10-103-60	SGA-10-103*	SGB-10-103	SGZ-10-103*
11 1/8" x 76"	SGS-11-76	SGS-11-76-60*	SGA-11-76	SGB-11-76	SGZ-11-76*
11 1/8" x 79"	SGS-11-79	SGS-11-79-60	SGA-11-79	SGB-11-79	SGZ-11-79
11 1/8" x 89"	SGS-11-89	SGS-11-89-60	SGA-11-89	SGB-11-89	SGZ-11-89
11 1/8" x 91"	SGS-11-91	SGS-11-91-60	SGA-11-91	SGB-11-91	SGZ-11-91*
11 1/8" x 101"	SGS-11-101	SGS-11-101-60*	SGA-11-101	SGB-11-101	SGZ-11-101*
14" x 86"	SGS-14-86	SGS-14-86-60	SGA-14-86	SGB-14-86	SGZ-14-86
14" x 103"	SGS-14-103	SGS-14-103-60	SGA-14-103	SGB-14-103	SGZ-14-103
14" x 107 1/2"	SGS-14-107	SGS-14-107-60	SGA-14-107	SGB-14-107	SGZ-14-107
14" x 113 1/2"	SGS-14-113	SGS-14-113-60	SGA-14-113	SGB-14-113	SGZ-14-113*
15" x 127 1/2"	SGS-15-127	SGS-15-127-60*	SGA-15-127	SGB-15-127	SGZ-15-127

Colors may vary due to manufacturing process. Guaranteed for 1 year from original purchase date.

Belt/Machine Compatibility **tech tips**

Belt Size	Machine(s)
10" x 87"	Rogers SB-1028, SF-1028, T&S Machine, Master Tool 1029
10" x 103"	Rogers SF-1036, T&S Machine, Master Tool PS1036
11 1/8" x 76"	Winona Van Norman BG-600
11 1/8" x 79"	RMC, Peterson RG-1203
11 1/8" x 89"	RMC-800, Serv-Equip PG-1229
11 1/8" x 91"	Peterson RG-1234, Kansas Instruments
14" x 86"	Automotive Craftsman
14" x 103"	Master Tool
14" x 107"	Kwik-Way 870 Master Surfacer
14" x 113 1/2"	Storm Vulcan/Anderson AB-1000A, Peterson PG-1400
15" x 127 1/2"	Storm Vulcan/Anderson AB-1540A, Anderson AB-1560, IDL HS-4350, Peterson PG-1500, Winona Van Norman BR-1500, BG-1515 & BG-1520



Semi-Synthetic Belt Resurfacer Coolant

- Rust-inhibiting
- For ALL belt resurfacers with a coolant sump
- Dilute 30 parts water to 1 part coolant

Size	Order No.
1 Gallon (3.79L)	SGB-10
5 Gallons (18.39L)	SGB-50

CYLINDER HEAD REBUILDING
CLEANING, ASSEMBLY & SAFETY
SHORT BLOCK REBUILDING
FLYWHEEL GRINDING
CRANKSHAFT/ TOOLS & SUPPLIES
MISCELLANEOUS
BRAKE SERVICE TOOLING
MEASURING TOOLS
V-TWIN & METRIC HARD PARTS



"We are committed to maintaining your privacy. Information about you and your business is never sold, rented or given to anyone outside of our company."

- Sue, Goodson Office Manager - 39 years of service

tech tips
from the techxperts™

4 Keys to Resurfacing Aluminum Heads

1 - Choose the correct abrasive

Use a speckled wheel segment to grind aluminum heads.

2 - Lubricate, Lubricate, Lubricate

Put a light coat of **Grind Aid (GRA-10)** on the abrasive to reduce aluminum build up. Speed up the traverse and reduce the cut to .0005" to .0010" per pass.

3 - Dress for Success

Keep grains open by dressing often. Don't dress before the last pass, but be sure to apply Grind Aid liberally so the stone yields a finer surface finish.

4 - Keep heat build-up to a minimum

The greatest danger is heat build up that can cause scoring as aluminum transfers to the stone. Take shallow cuts and use plenty of lubrication to prevent this.

CYLINDER HEAD REBUILDING

CLEANING, ASSEMBLY & SAFETY

SHORT BLOCK REBUILDING

CRANKSHAFT/ FLYWHEEL GRINDING

MISCELLANEOUS TOOLS & SUPPLIES

TOOLING

MEASURING TOOLS

V-TWIN & METRIC HARD PARTS

Silicon-Carbide Abrasive



Silicon-Carbide Abrasive



Aluminum Oxide & Silicon-Carbide Abrasive

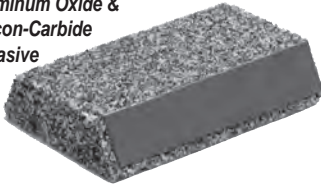

Aluminum Oxide Abrasive



Resurfacing Wheel Segments

Segments are available in a variety of compositions.

Match the abrasive to the material for best results and longest life. Order segments in 8, 10 or 12 piece sets.

Width	Thickness	Length	Application	Abrasive	Color	Order No.
2.56"/65mm	0.98"/25mm	3.94"/100mm	Cast Iron & Aluminum	Silicon-Carbide	Black	GS-PBS
			Steel & Hardened Metals	Aluminum Oxide	White	GS-PBS-1
			Aluminum, Cast Iron,	Aluminum Oxide	Speckled	GS-PBS-2
			Hardened Iron & Steel	Aluminum Oxide and Silicon-Carbide		
			Steel & Hardened Metals	Aluminum Oxide	Ruby	GS-PBS-3
For Peterson/Peterson Berco 1055 AWL, RSC950 (std.), SYP320, -360, -1000, -1300, RSC1200, -1550, RPYS1500 models. For Winona Van Norman SM-2000, SM-4000/5000, MG-4000, SM-6000C/6000A and MG-3000/3850 models. For Storm Vulcan RT7Y Late (Serial No. 103152 and up) and RT 17Y Late (Serial No. 128697 and up) models.						
3.13"/79mm	0.81"/21mm	3.13"/79mm	Cast Iron & Aluminum	Silicon-Carbide	Black	GS-SVS
			Aluminum, Cast Iron, Hardened Iron & Steel	Aluminum-Oxide and Silicon-Carbide	Speckled	GS-SVS-2
For Peterson/Peterson Berco RG-32, RTY, RG-35, RG-300/900 models. For Storm Vulcan RT 7Y Early (Serial no. up to 103151) and RT 17Y Early (Serial no. up to 128696)						
1.97"/50mm	0.67"/17mm	3.62"/92mm	Cast Iron & Aluminum	Silicon-Carbide	Black	GS-RGS
For Peterson/Peterson Berco RG-32, RG-300/900 models.						
2.56"/65mm	0.79"/20mm	3.94"/100mm	Steel & Hardened Metals	Silicon-Carbide	Black	GS-KWS
			Aluminum, Cast Iron, Hardened Iron & Steel	Aluminum-Oxide and Silicon-Carbide	Speckled	GS-KWS-2
For Kwik-Way 858 and 862 models						

tech tips
from the techxperts™

To maintain proper cutting action Goodson strongly recommends that you replace your wheel head resurfacing segments in full sets. See your user's manual for wheel diameter and number of segments required. Due to manufacturing process colors may vary.

Need help choosing the abrasive? Call the Goodson Techxperts™

Resurfacing Segments are guaranteed for 1 year from original purchase date

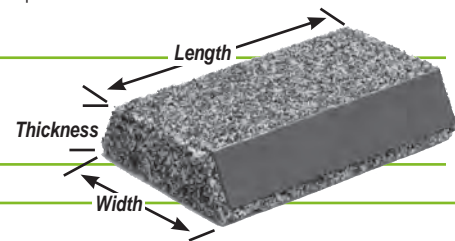

Surface Grinding Coolant for Segments and Single-Piece Wheels

- Synthetic
- Water soluble
- Non-foaming • Dilute 20:1



Size	Order No.
1 Gallon / 3.78 L	SGC-10
5 Gallons / 18.93 L	SGC-50

Import / Metric Cylinder Head Stud Stretchers

- Save time, don't remove the studs from a head for resurfacing
- Put stud stretchers on two studs and leave the rest
- Sold in pairs

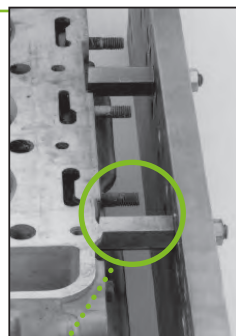

Length	Thread	Order No.
3"	8mm x 1.25	SS-20
3 3/4"	8mm x 1.25	SS-30
3 3/4"	10mm x 1.25	SS-40



Cylinder Head Resurfacing

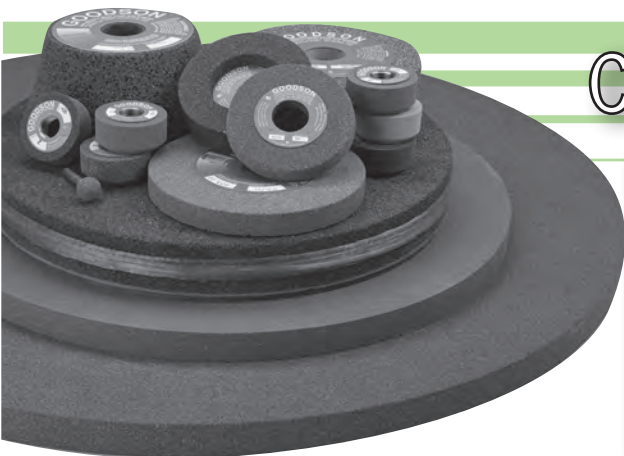

The most complete abrasives program in the industry ...

1. Consistent high quality abrasives

Each Goodson resurfer wheel is made to the highest standards of roundness, balance and strength. Extensive quality control, start-to-finish, lets us back our abrasives with our Iron-Clad Guarantee of total satisfaction.

2. Full inventory

Since we specialize in the distribution of abrasives to machine shops world wide we always carry an extensive inventory. Call Goodson, we have what you need on our shelves.

3. Same day shipping

We usually ship your order the same day that we receive it. Along with our huge inventory, our shipping speed ensures consistently faster delivery when you order from Goodson.

24 Grit Blanchard Grinder Wheels

- Includes gasket pad for mounting onto a Blanchard Grinder
- Also ideal for resurfacing clutch plates
- Wheel measures 11" x 5" x 9"
- Tape wound for added safety
- Excellent grade for most grinding conditions and metals
- Order No. **U69755**



Single-piece Resurfer Wheels

- Meet or exceed OE standards established for general purpose grinding applications
- Silicon-Carbide abrasive • Banding will wear off to expose more abrasive



U342040



GS-48

Peterson			
Machine Model(s)	Size: dia. x height x face width	Grit	Order No.
All 14" Dry Grinders	14" x 1½" x 4" Plate	24	U342040 
All 14" Dry Grinders	14" x 1½" x 4" Plate	36	GS-48

Grinding Wheels are guaranteed for 1 year from original purchase date



GS-545B



GS-545BL

NOTE: Plates are no longer painted, resulting in less warpage

Kwik-Way			
Machine Model(s)	Size: dia. x height x face width	Grit	Order No.
545B,856,855-5,860	14" x 3" x 1½" (Serrated) Plate	24	GS-545B
545BL,860A, L & T	16" x 3" x 1½" (Serrated) Plate	24	GS-545BL

Grinding Wheels are guaranteed for 1 year from original purchase date



FG-1165-G



FG-1070A-G



FG-1045-G

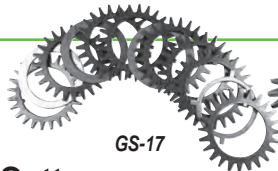

GS-17



GS-00



GS-0

Grinding Wheel Dressers & Replacement Cutters

Diamond Dresser Tools are available on pages 114-115

Cutter Assemblies				Replacement Cutters					
Applications	OD	W	Order No.	Pieces	Washers	OD	ID	Thick	Order No.
Peterson (12mm shaft)				8 stars	3	2.375"	1.500"	.093"	GS-17
					1 w/locking tangs	1.750"	1.500"	.060"	
WVN SM2000, 4000, 5000, 6000C, 6000A, MG3000, 3850	1.250"	0.978"	FG-1165-G	7 stars	none	1.250"	0.313"	.095"	FG-1161-G
Peterson & DCM	2.375"	2.262"	FG-1070A-G	5 stars		2.375"	1.132"	.1375"	FG-1070-G
Hand held			FG-1045-G	1 stone	none	1.500"	0.313"	.6250"	FG-1044-G
Desmond Dresser for wheels to 10"			GS-0	4 blades, 2 spacers		0.250"			GS-00
				4 blades, 2 spacers		0.500"			GS-11

CYLINDER HEAD REBUILDING

CLEANING, ASSEMBLY & SAFETY

SHORT BLOCK REBUILDING

FLYWHEEL GRINDING CRANKSHAFT/

MISCELLANEOUS TOOLS & SUPPLIES

BRAKE SERVICE TOOLING

MEASURING TOOLS

V-TWIN & METRIC HARD PARTS

"When you call Goodson, you speak to a person first - not a machine. We work hard to make sure we answer your calls promptly and avoid keeping you on hold."

- Ashley, Goodson Receptionist, 2 years of service



Scan the code at right with your smart phone or other smart device to watch **Magnetic Particle Inspection** on the Goodson website.



CYLINDER HEAD
REBUILDING

CLEANING,
ASSEMBLY & SAFETY

SHORT BLOCK
REBUILDING

CRANKSHAFT/
FLYWHEEL GRINDING

MISCELLANEOUS
TOOLS & SUPPLIES

BRAKE SERVICE
TOOLING

MEASURING
TOOLS

V-TWIN & METRIC
HARD PARTS



MMP-100

Ergonomic handle design for less operator fatigue.

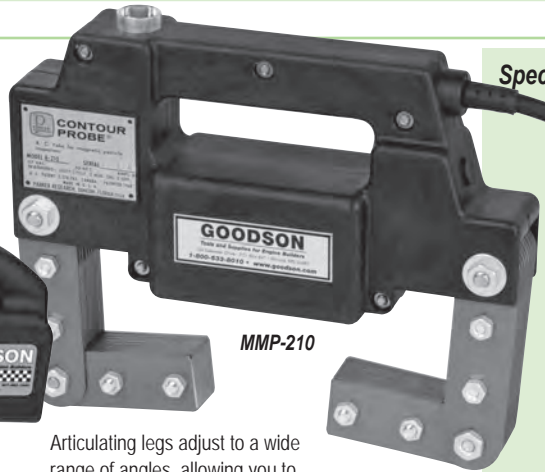

MMP-210

Articulating legs adjust to a wide range of angles, allowing you to test uneven surfaces with ease

Specifications



MMP-100 / MMP-100S

Physical: 7 3/8" x 9 1/4" x 2 1/8"
187 x 235 x 54mm
Max. Span: 12" (304.8mm)
across poles
Voltage: 115V (MMP-100)
230V (MMP-100S)
Line Current: 4 amp (MMP-100)
3 amp (MMP-100S)
Weight: 6.5 lb (2.95 kg)
Cord: 10' L, 3-wire



MMP-210

Physical: 10 1/2" x 11" x 2 3/4"
266 x 280 x 70mm
Max. Span: 18" (457mm) across
poles
Voltage: 115V (MMP-210)
230V (MMP-210S)
Line Current: 8 amp (MMP-210)
3 amp (MMP-210S)
Weight: 13 lb (5.9 kg)
Cord: 10' L, 3-wire

Magnetic Crack Detection Units

- Articulating legs conform to virtually any surface configuration
- Designed for one-person operation • Lightweight • No transformer box to drag around • 230V units feature a pigtail on the cord • Easy to access switches • Full 1-Year Manufacturer's Warranty for Repair • 50% duty cycle (example: 2 minutes on, 2 minutes off) • Produce a strong AC magnetic field



Description	Order No.
115V Electronic Crack Detector with 10# Pull	MMP-100
115V Heavy Duty Electronic Crack Detector with 22# Pull	MMP-210
230V Electronic Crack Detector with 10# Pull (subject to stock on hand)	MMP-100S

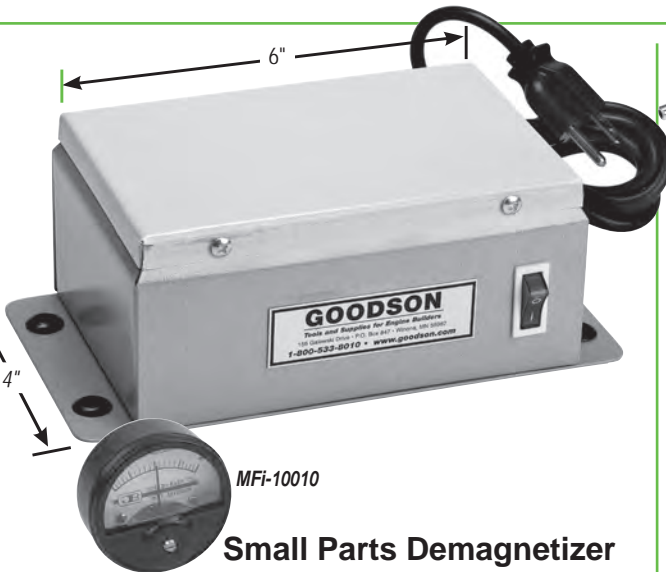

MFI-10010

Small Parts Demagnetizer

Don't jeopardize your engine work! Heat, friction and magnetic particle inspection can cause magnetism to build up in your engine components. If not removed, it will attract ferrous materials in engine lubrication and may cause premature engine failure. This easy to use table demagnetizer is a fast and easy way to ensure that all residual magnetism is eliminated from engine components. Use with the optional Magnetic Field Indicator (MFI-10010) to be sure all remaining magnetism has been fully eliminated.

Description	Order No.
Small Parts Demagnetizer	SPD-46
Magnetic Field Indicator	MFI-10010



Magnetic Powder Applicators

- A quick & easy method for distributing magnetic powder

Description	Order No.
Atomizer Assembly for small areas (1 oz.)	MM-301
Applicator Bulb for large areas	WCD-266-G
Replacement Bulb for Atomizer Jar	MM-301-1

Non-Fluorescent Magnetic Powder for Dry Method Particle Inspection

- Works with all dry magnets including Magnaflux® and Parker
- Store in a moisture free environment

Color/Size	1 lb.	5 lb.	25 lb.
White/Gray	WCD-100-G	WCD-500-G	WCD-2500-G
Yellow	WCD-101-G	WCD-501-G	WCD-2501-G
Red	WCD-103-G	WCD-503-G	WCD-2503-G



Crack Detection



Scan the code below with your smart phone or other smart device to view our **Chemical Crack Detection** Video on the Goodson website.



Alumni-Chek

- Find surface cracks on aluminum & cast iron without electricity or special lights
- Ideal for aluminum, but also works on brass, cast-iron, steel, carbide, and Stellite • Even the tiniest cracks show as bright red • Complete kit includes Cleaner, Penetrant, Developer and Shop Towels (also available separately)

Description	Order No.	Incl.
Complete Kit	AC-KIT*	▼
Cleaner Aerosol*	AC-1*	x
Penetrant Aerosol*	AC-2*	x
Developer Aerosol*	AC-3*	x
5 Towels	WST-5	x

*Hazardous Goods Fees Apply When Shipped By Air



Maxxeon® WorkStar® 364 USB Rechargeable UV Leak Detection Pen/Inspection Light

- 3.7V 570mAh, 2.1 Wh Lithium battery with USB charger
- Run time: 35 min. continuous, 2 hr. intermittent operation
- Use with Goodson Glow for crack detection
- Easily adjustable beam to suit application
- Drop tested to 6 feet
- Order No. **DFL-364**



Magnetic Crack Detection Spray

- Use with your magnetic crack inspection unit
- Applies quickly and easily — just spray it on the area you want to check
- Glows brightly under black-light
- 32 oz. non-aerosol spray
- Order No. **MFA-32**

tech tips

from the techxperts™

- Step 1:** Spray cleaner evenly on the surface and allow it to dry completely.
- Step 2:** Spray on Penetrant. Allow to saturate for 5 minutes. Wipe off excess to avoid false readings.
- Step 3:** Spray on thin layers of developer to build up a uniform powdery film.
- Step 4:** Flaws and cracks will glow brightly when viewed under the black light (Applies only to Goodson Glow).



GOODSON Glow Crack Detection Sprays

- Easily detect surface cracks that could be missed with just visual inspection
- Cracks & flaws glow brightly under black light after treatment with Cleaner, Penetrant and Developer

Description	Order No.
Goodson Glo Cleaner Aerosol*	GLO-1*
Goodson Glo Penetrant Aerosol*	GLO-2*
Goodson Glo Developer Aerosol*	GLO-3*

*Hazardous Goods Fees Apply When Shipped By Air

Crack Detection Powder & Oil Carrier

- For wet method crack detection
- Mix powder with oil carrier
- Use with Ultra Violet Inspection Light to view results

	Size	Order No.
Powder	4 oz. / 113.4g	GCR-14A-4
	1 lb. / 453.6g	GCR-14A
Oil Carrier	5 Gallons / 18.93L	GCR-50



Magnetic Crack Detection Oil

- Oil impregnated with magnetic powder (**GCR-14A, GCR-14A-4**) to glow under black-light
- Low viscosity oil flows into small cracks • Oil clarity makes cracks easier to see • Aerosol Spray is pre-mixed oil and carrier
- Order No. **MFA-50**

CYLINDER HEAD REBUILDING
CLEANING, ASSEMBLY & SAFETY
SHORT BLOCK REBUILDING
FLYWHEEL GRINDING
CRANKSHAFT/ TOOLS & SUPPLIES
MISCELLANEOUS
BRAKE SERVICE TOOLING
MEASURING TOOLS
V-TWIN & METRIC HARD PARTS

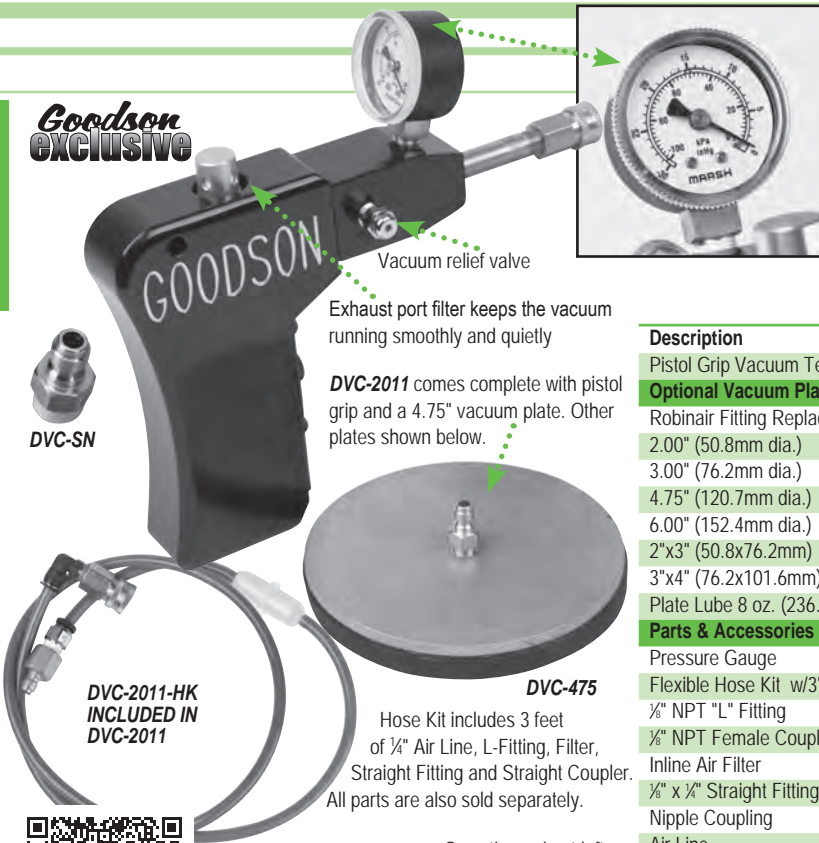
**Goodson
exclusive**

DVC-SN

DVC-2011-HK
INCLUDED IN
DVC-2011

DVC-475

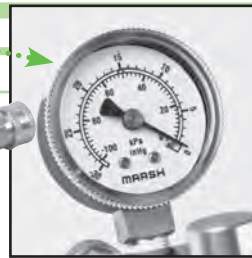
Exhaust port filter keeps the vacuum
running smoothly and quietlyDVC-2011 comes complete with pistol
grip and a 4.75" vacuum plate. Other
plates shown below.Hose Kit includes 3 feet
of 1/4" Air Line, L-Fitting, Filter,
Straight Fitting and Straight Coupler.
All parts are also sold separately.Scan the code at left
with your smart phone
or other device to view
the product video.**Pistol Grip Vacuum Tester**

- Lightweight - only 1.9 lbs. without the plate
- Pulls and holds up to 24" vacuum on as little as 90 PSI
- Quick coupling Robinair fittings
- Easy to reach controls for single-handed operation
- Hard-anodized billet aluminum
- Tester includes one 4.75" vacuum plate and hose kit with filter

Description	Order No.	
Pistol Grip Vacuum Tester Kit	DVC-2011	Incl. ▼
Optional Vacuum Plates		
Robinair Fitting Replacement Plate Set	DVC-7KIT	▼
2.00" (50.8mm dia.)	DVC-2	x
3.00" (76.2mm dia.)	DVC-3	x
4.75" (120.7mm dia.)	DVC-475	x x
6.00" (152.4mm dia.)	DVC-6	x
2"x3" (50.8x76.2mm)	DVC-23	x
3"x4" (76.2x101.6mm)	DVC-34	x
Plate Lube 8 oz. (236.6 mL)	DVC-PL	x
Parts & Accessories		
Pressure Gauge	DVC-GAUGE	
Flexible Hose Kit w/3' Air Line (optional)	DVC-2011-HK	▼
1/8" NPT "L" Fitting	CF-2003-L	x x
1/8" NPT Female Coupling	LDP-AR-6	x x
Inline Air Filter	DVC-FILTER	x x
1/8" x 1/4" Straight Fitting	DVC-SF	x x
Nipple Coupling	DVC-1N	x x
Air Line	CF-2001-AL	x x
Robinair Fitting	DVC-SN	
1/8" NPT Male Coupling	DVC-1M	
6 Pc. Replacement Foam Set (1 of each size)	FOAM-KIT	
Replacement Foam Mat - 11" x 31" x 3/8"	DVC-1131	

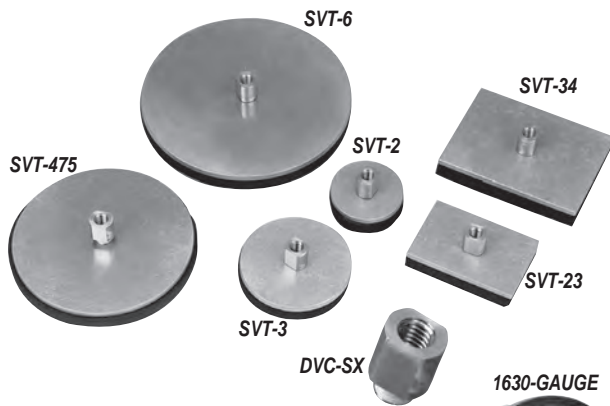
**Sioux-Style Replacement
Vacuum Tester Parts**

- For Sioux™ 1630K Tester no longer made
- Closed cell foam for an exceptional seal

Sioux-Style Replacement Plates for the 1630K Tester

Size	OE No.	Order No.
2" / 50.8mm dia.	1630-2	SVT-2
3" / 76.2mm dia.	1630-3	SVT-3
4.75" / 120.7mm dia.	1630-4	SVT-475
6" / 152.4mm dia.	1630-6	SVT-6
2"x3" / 50.8 x 76.2mm		SVT-23
3x4" / 76.2 x 101.6mm		SVT-34

Replacement Parts for the 1630K Tester

Replacement Fitting	DVC-SX
Replacement Gauge	1630-GAUGE

**Heavy Duty Manual
Vacuum Tester**

- A steady reading of 25" (63.5cm) indicates proper valve seating
- All metal construction
- 4 3/4" plate, fittings and plate lube included
- DVC Plates (above) will fit this tester

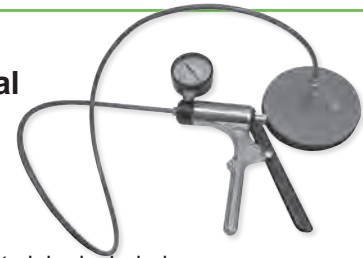

Description	Order No.
Manual Vacuum Tester	DVC-101-HD
Replacement 4.75" Plate	DVC-475
Plate Lube - 8 oz. (236.6 mL)	DVC-PL

Vacuum Testing

Vacuum testing is the fastest method for testing valve to seat integrity. Simply assemble your machined cylinder head and install the spark plugs. Use a reliable vacuum source producing approximately 24" HG on the vacuum gauge and a closed cell foam test plate with a through fitting to draw down or evacuate the combustion chamber.

Once you've reached 24" HG on the gauge and close the vacuum to the chamber. Watch the gauge for a drop in vacuum. It should hold steady confirming that you have achieved valve to seat mating.

Coat the face of your closed cell foam test plate with Plate Lube (DVC-PL) to condition the foam. This produces a soft, yielding material that will fill minor head surface blemishes or imperfections.

tech tips
from the techperts™



Handy toggle switch turns the unit on and off.

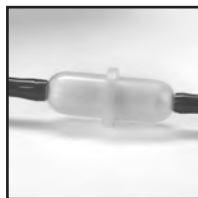

Inline filter keeps debris out of the unit for longer life and more power.



Vacuum control knob has 3 settings — continuous, hold and release

Trego Electric Vacuum Tester

- Check valve to seat seal right on the bench or in the engine compartment — no special set up is required
- This unit is equipped with a vacuum piston pump and generates up to 850 Mbar of vacuum • Reads in PSI
- A built-in pressure control knob allows you to control vacuum settings accurately • 115V, 60Hz, 67W motor
- Dimensions: 9⁷/₈"L x 6³/₄"W x 4¹/₂"H

Description	Order No.	Incl.
Electric Vacuum Tester	VT-KIT	▼
2.00" (50.8mm dia.)	DVC-2	x
3.00" (76.2mm dia.)	DVC-3	x
4.75" (120.7mm dia.)	DVC-475	x
6.00" (152.4mm dia.)	DVC-6	x
2"x3" (50.8x76.2mm)	DVC-23	x
3"x4" (76.2x101.6mm)	DVC-34	x
Plate Lube 8 oz. (236.6 mL)	DVC-PL	x
1/4" Air Line (6')	CF-2001-AL	x
Inline Air Filter	DVC-FILTER	x
1/8" NPT Female Coupling	LDP-AR-6	x

Jet Valve Eliminator Kit

- Some Mitsubishi/Chrysler 2.6L heads had jet valves while some didn't
- This kit lets you use a jet valve equipped head in place of one without
- 11mm diameter, 1.0 pitch threaded plugs replace entire valve body assembly
- Easier than welding the holes closed
- Package of 4 converts one 2.6L head
- Order No. **JVE-26**



.235" Crack Repair Kit

- Complete kit includes everything you need to repair cracked cast iron heads using the cold repair process • Download the Goodson Crack Repair Manual by scanning code at right with the camera on your smart phone or other smart device



Description	Order No.	Incl.
Complete Repair Kit:	CRK-150	▼
.235" x 1 ⁵ / ₁₆ " Threaded Iron Plugs (100 Pk.)	CRP-235	1
High Speed Steel Drill	CRD-235	1
High Speed Steel Tapered Reamer	CRR-235	1
High Speed Steel Tapered Taps	CRT-235	2
Cut-Off Saw with Blade	CR-SAW	1
Replacement Saw Blade	CR-BLADE	1
Cutting & Tapping Fluid*	CTF-14	1
All Weather Seal (16 oz.)	AWS-16	1
Ceramic Motor Seal (16 oz.)	CRS-16	1

*Hazardous Goods Fees Apply When Shipped By Air

Threaded Crack Repair Plugs

- Iron • Tapered • Threaded plugs
- Cast to rigid specifications

Plug Size	Qty.	Order No.
.200" x 1 ⁵ / ₁₆ "	100	CRP-200
.200" x 1/2"	100	CRP-201
.235" x 1 ⁵ / ₁₆ "	100	CRP-235
.327" x 1 ⁵ / ₁₆ "	50	CRP-327



High Speed Steel Drills

- 118° points for fast chip removal

Plug Size	Order No.
.200"	CRD-200
.235"	CRD-235
.327"	CRD-327



Tapered Reamers

- High Speed Steel

Plug Size	Order No.
.200"	—
.235"	CRR-235
.327"	CRR-327



Tapered Taps

- High strength steel machined to match plug taper & thread

Plug Size	Order No.
.200"	CRT-200
.235"	CRT-235
.327"	CRT-327



CYLINDER HEAD
REBUILDING

CLEANING,
ASSEMBLY & SAFETY

SHORT BLOCK
REBUILDING

CRANKSHAFT/
FLYWHEEL, GRINDING

MISCELLANEOUS
TOOLS & SUPPLIES

BRAKE SERVICE
TOOLING

MEASURING
TOOLS

V-TWIN & METRIC
HP PARTS



"At Goodson, we're always on the lookout for new or improved tools that make engine rebuilding easier. If you have a tool you think we'd be interested in, give us a call."

- Richard, Goodson Product Manager, 25 years of service

CYLINDER HEAD
REBUILDING

CLEANING,
ASSEMBLY & SAFETY

SHORT BLOCK
REBUILDING

CRANKSHAFT/
FLYWHEEL GRINDING

MISCELLANEOUS
TOOLS & SUPPLIES

BRAKE SERVICE
TOOLING

MEASURING
TOOLS

V-TWIN & METRIC
HARD PARTS

shown actual size



melted center
reveals
overheating

Heat Tabs

- Provides visual evidence of engine overheating
- Special heat sensitive metal centers melt and fall out when engine exceeds the melting point of the tab
- 100 Heat Tabs per package
- Attach to heads with Heat Tab Adhesive (below)

Description	Melting Point	Order No.
Round Heat Tabs	255-260° F / 124-127° C	RHT-100
Round Ironite Heat Tabs	255-260° F / 124-127° C	HT-100RD
Round Diesel Heat Tabs	225-235° F / 107-110° C	DHT-100
Heat Tab Adhesive (3 oz./88.7mL tube)		HTA-3

Leak Detection Mat

- Commercial-grade Neoprene
- Resists petroleum products, abrasion, swelling, sunlight and aging
- Repair worn mats or make custom leak detection plates
- Measures 3' x 4' x 3/16" thick
- Order No. **LDP-34MAT**



Rust Inhibitor for Pressure Testing

- Clear fluid inhibits rust and does not discolor or cloud the test tank solution
- Lets you see better to pressure test
- Biocide and anti-rust additives extend tank solution life while preventing corrosion
- Synthetic formula
- Mix 20:1 with water
- Yields 20 gallons
- Order No. **PRI-10**



Seal-All™

- Seals pin holes, porosity and small cracks in heads & blocks
- Penetrates and seals
- Out-performs ceramics
- Bonds with existing rust & corrosion to prevent spread
- Heat at 175°-200°F (79.4°-93.3°C) for 4 hours to cure
- Not for use on assembled engines
- 32 oz. (946 mL)
- Order No. **CPS-32**



Fluid Weld®

- For cast iron or aluminum heads and blocks
- Use as a sealant for threaded or press-fit parts like valve guides and seats, threaded crack repair plugs, replacement studs, etc.
- Seals small cracks • Non-toxic
- Non-flammable
- **NOT** for use on assembled engines
- Withstands temperatures to 3000°F



Size	Order No.
2 oz. (59 mL)	FW-2
8.8 oz. (260 mL)	FW-88

All Weather Seal

- Seals intakes & head gasket leaks
- Seals cracks in cylinder heads & engine blocks
- Prevents anti-freeze from seeping through gaskets and hoses
- Lubricates water pump seals
- Mixes with all anti-freeze and coolant
- Works in less than 5 minutes
- Fast-acting, non-corrosive, non-clogging
- Can be used with coolant or anti-freeze
- 16 oz./455 mL • Order No. **AWS-16**



Ceramic Motor Seal

- Permanently seals leaking head gaskets, cracked heads and blocks (aluminum or cast iron)
- Coats the engine to inhibit rust formation and salt water corrosion during normal operation
- Seals porous castings in the cooling system
- Stops coolant leaks
- Not compatible with any anti-freeze or coolant, follow instructions on package
- Promotes heat dissipation for added power
- 16 oz./455 mL
- Order No. **CRS-16**



Misc. Cylinder Head

S-373P
Pilot shown installed

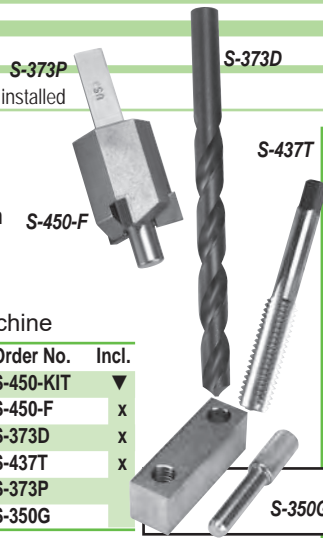

Rocker Arm Stud Conversion Kit

- Convert pressed-in rocker arm studs to threaded studs
- Remove stud, face stud boss, then drill and tap the stud hole
- Use with a seat and guide machine

Description	Order No.	Incl.
Conversion Kit	S-450-KIT	▼
Stud Boss Facer	S-450-F	x
3/8" Drill Bit	S-373D	x
7/16" x 14 Thread Tap	S-437T	x
3/8" Pilot	S-373P	
2 Pc. Tap Guide	S-350G	



Economy Cylinder Head Holder

- Holds head with either side up
- Tapered pins fit virtually any size head bolt hole and loosen with a twist
- Ideal for guide sizing with ample clearance to remove arbors and reamers
- Two piece set • Order No. **HH-100-G**

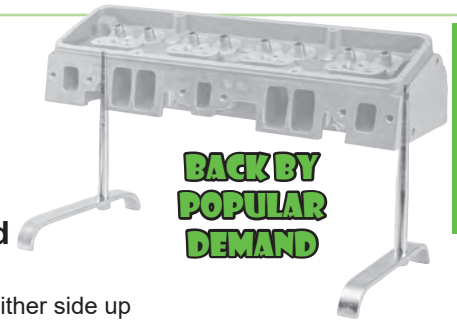

BACK BY POPULAR DEMAND

CYLINDER HEAD REBUILDING

CLEANING, ASSEMBLY & SAFETY

Manual Rocker Arm Stud Puller

- Heavy-duty ball bearing action
- Creates less stress and friction
- Fits 5/16" (7.9mm) and 3/8" (9.53mm) threaded studs
- Not recommended for use on thermally cleaned heads

Description	Order No.
Complete Stud Puller	SP-600
Drive Nut	SP-601
Puller Body	SP-602
5/16" and 3/8" Mandrel	SP-603
Thrust Bearing	SP-604

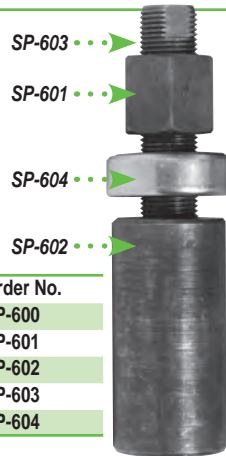

Ultra-Sturdy Cylinder Head Holder

- 360° stand holds head securely in position
- Tie-rod to prevent tipping
- Slip-resistant neoprene covered rails
- Fits domestic, foreign, truck & motorcycle heads
- 3-piece set
- Order No. **HH-450**

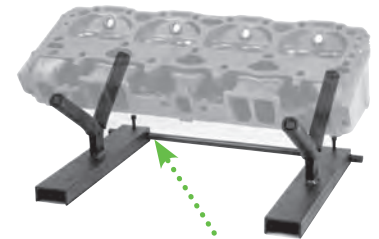

Set screws hold the two pieces firmly in place

SHORT BLOCK REBUILDING

FLYWHEEL, GRINDING

Universal Threaded Stud Extractor

- Use with your pneumatic impact tools & sockets (15/16" socket removes, 1 1/16" installs)
- Requires only 3/4" clearance to adjacent studs
- For threaded studs only • Fits 3/8" socket
- Hardened 3-jaw clamping system
- Internal taper support • Hollow body allows long studs to extend through the tool
- 1 1/2" dia. x 2 7/8" long • 1/4" - 1/2" range

Description	Order No.
Universal Stud Extractor	PSR-375
Replacement Parts	PSR-JAWS
Spring Set (3 Piece)	PSR-3S
Snap Ring	PSR-SR



Universal Cylinder Head Holder

- Accommodates all types of cylinder heads
- Sturdy, durable, lightweight aluminum construction
- Slip-resistant neoprene covered rails
- Place heads quickly into any position and rotate them easily through 360°
- Requires no bolts, clamps or adaptors
- 2 piece set • Order No. **HH-200**

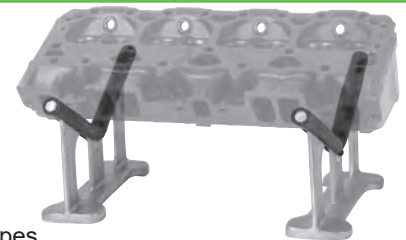

MISCELLANEOUS TOOLS & SUPPLIES

CRANKSHAFT/ FLYWHEEL, GRINDING

TOOLING

MEASURING TOOLS

Torque-Angle Indicator

- When torque is given as degrees of turn past a certain ft./lb., use this gauge to show degrees
- Hold metal base with one hand
- Plastic dial turns as you tighten
- Fits between a socket-driven extension and the socket
- 1/2" square drive
- Order No. **TQR-4554**



Professional Measuring & Inspection Stand

- Length adjusts up to 23"
- Rotate work to view or measure
- Solid aluminum frame with self lubricating, corrosion and chemical-resistant wear surfaces
- Order No. **PMIS-30**

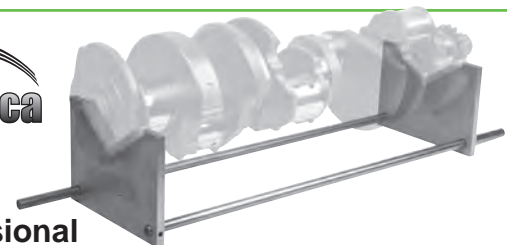

V-TWIN & METRIC HARD PARTS



"We pride ourselves on getting orders to you quickly. We stock a wide variety of products in our warehouse and we use most shipping carriers so you can receive your order in 3 days or less."

- Shawn K. Goodson Shipping, 4 years of service

CYLINDER HEAD
REBUILDING

43 Piece Deluxe Porting Kit

- Professional grade porting supplies
- Packed in a clear plastic storage case

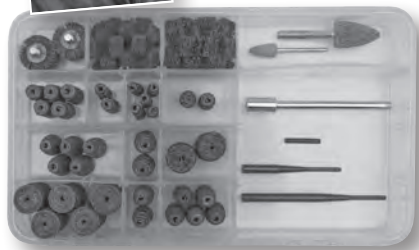

Description	Order No.	Incl.
43 Pc. Kit	DPK-100	▼
Replacement Abrasives	Grit	Kit Qty.
Flap Wheels - 1"x1"x1/4"	120	2
	AFW-1-120	x
Cross Buffs 3 Ply, 1 1/2"	Med.	2
	CB-15M-HD	x
	Very Fine	2
	CB-15VF-HD	x
Cross Buff/Flapwheel Mandrel		1
	CB-MANDREL	x
1/4" Dia. Straight	40	2
	SCR-250-40	x
Cartridge Rolls	80	5
	SCR-250-80	x
3/8" Dia. Straight	40	2
	SCR-375-40	x
Cartridge Rolls	80	5
	SCR-375-80	x
3/4" Dia. Straight	40	2
	SCR-750-40	x
Cartridge Rolls	80	2
	SCR-750-80	x
1/2" Dia. Half Tapered	40	2
	HTR-500-40	x
Cartridge Rolls	80	5
	HTR-500-80	x
5/8" Dia. Full Tapered	40	2
	FTR-625-40	x
Cartridge Rolls	80	5
	FTR-625-80	x
Cartridge Roll Mandrel	2 3/4" Long	1
	CR-275	x
	4" Long	1
	CR-40	x
Mounted Points - 3/8" x 3/4"	60	1
	GM-B52	x
	1 1/16" x 1 1/4"	60
	GM-12	x

See next page for replacement abrasives

CLEANING,
ASSEMBLY & SAFETY

SHORT BLOCK
REBUILDING

CRANKSHAFT/
FLYWHEEL GRINDING

MISCELLANEOUS
TOOLS & SUPPLIES

BRAKE SERVICE
TOOLING

MEASURING
TOOLS

V-TWIN & METRIC
HARD PARTS

Intake Port Reshaping Kit

- Superior formula uses 2-part epoxy
- Won't shrink when dry
- Mix ratio is 1:1 by weight
- Mix and knead the parts together by hand until the yellow and black colors have combined to make a uniform olive green color
- Working time at 70°F: Golf ball size mix: 40 minutes max.; Baseball size mix: 30 minutes max.
- Cure time at 70°F: full hardness in 6 to 8 hours
- Once cured, forms a hard coating resistant to abrasion, impact, water, chemicals and solvents
- **NOT** for use in contact with potable water or exhaust ports
- Can be milled or machined
- Withstands temperatures up to 500°F/ 260°C
- Kit includes epoxy, gloves and mixing sticks
- Yields 16 oz./453.6g of material
- 24 month shelf-life
- Order No. **PRK-99**



tech tips

Adhesion of PRK-99 will be only as good as the cleanliness and soundness of the substrate. Remove all dirt, oil and grease. Soda blasting is acceptable. Scraping, wire brushing and other manual cleaning methods may also work. Do NOT use a petroleum-based cleaner before using PRK-99, it will prohibit adhesion.

NOTE: Extreme caution must be used when porting & polishing. Be sure to wear safety glasses.

small engine powersports

40 Piece Small Engine Porting Kit

- Professional grade porting supplies
- Packed in a clear plastic storage case



Description	Order No.	Incl.
40 Pc. Kit	SEPK-5	▼
Replacement Abrasives	Grit	Kit Qty.
Flap Wheels - 1"x1"x1/4"	120	2
	AFW-1-120	x
Cross Buffs 2 Ply 3/4"	Very Fine	2
	CB-75VF	x
	1"	Medium
	CB-1M	x
	Very Fine	2
	CB-1VF	x
	1 1/2"	Very Fine
	CB-15VF	x
Cross Buff/Flapwheel Mandrel		1
	CB-MANDREL	x
3/8" Dia. Straight	80	4
	SCR-375-80	x
Cartridge Rolls	120	4
	SCR-375-120	x
	320	4
	SCR-375-320	x
3/8" Half Tapered Cartridge Rolls	80	4
	HTR-375-80	x
3/8" Full Tapered	80	4
	FTR-375-80	x
Cartridge Rolls	120	4
	FTR-375-120	x
1" x 2 Yds. Abrasive Roll	120	1
	UR-1-120	x
	320	1
	UR-1-320	x
Cartridge Roll Mandrel	2 3/4" Long	1
	CR-275	x
	4" Long	1
	CR-40	x

See next page for replacement abrasives

Quick Change Mandrels & Abrasive Sleeves

- 5 sleeves per pack • 1" x 1"
- Mandrel has 1/4" shaft



Description	Grit	Order No.
Mandrel		GMS-101
Sleeves	40	GMS-140
5 Pack	60	GMS-160

Variable Speed Control



- Vary tool speed from 200 to 25,000 RPM
- Control switch with 3 settings – Variable Speed, OFF and Full Speed
- Speed control dial
- 31 1/2" long grounded cord with standard US plug • Fuse protected
- Built in grounded control outlet

- Not compatible with brushless motors
- Order No. **GEO-SC**

Professional Porting & Polishing Tools

Aluminum Oxide Cloth Utility Shop Rolls

- 1" x 50 yards
- Easy to use ... just unroll and tear to length
- Use with butterfly mandrels at right

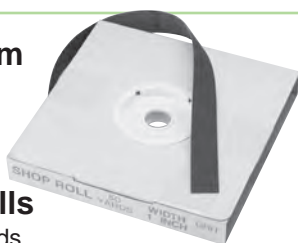

Grit	Order No.
60	UR-1-60
80	UR-1-80
100	UR-1-100
120	UR-1-120
180	UR-1-180
320	UR-1-320

Crocus Cloth

- Must be used with Lapping Oil
- Great for final touch-ups on cranks, rod pins, valve stems, cams, etc.
- Use with slotted mandrels at right

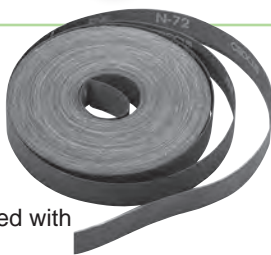

Description	Order No.
1" x 50 yd. Roll	UR-1-CROCUS
4 oz. Lapping Oil	LP-LO-4
8 oz. Lapping Oil	LP-LO-8

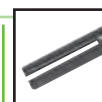

Slotted Butterfly Mandrels

- Use with roll abrasives such as those at left
- Several lengths available

Length	Order No.
3"	BM-3
6"	BM-6
8"	BM-8

Want a different abrasive? We can make it in-house. Contact us for more information!

Replacement Abrasive Packs and Mandrels

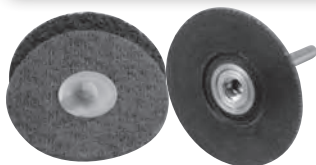

Replaceable Roll Lock Discs

10 per pack

Dia.	Order No.
2" Medium	RSCD-2M
2" Coarse	RSCD-2C
3" Medium	RSCD-3M
3" Coarse	RSCD-3C
Disc Holder	Order No.
2" Dia.	RLH-2
3" Dia.	RLH-3



Aluminum Machining Aid

- Designed for aluminum
- For porting & polishing with cartridge rolls, rotary files, emery cloth or Cross Buffs®
- Safe for cast iron
- 32 oz./946.4mL
- Order No. PF-32

HazMat shipping charges apply when shipped by air

Straight Cartridge Rolls

- 1½" long, ½" hole
- Fully glued • Box of 50

Dia.	Grit	Order No.
¼"	40	SCR-250-40
	80	SCR-250-80
	120	SCR-250-120
⅜"	40	SCR-375-40
	80	SCR-375-80
	120	SCR-375-120
½"	40	SCR-500-40
	60	SCR-500-60
	80	SCR-500-80
¾"	40	SCR-750-40
	80	SCR-750-80
	120	SCR-750-120

Roll Mandrels

Use with straight and tapered cartridge rolls • ½" pilot x ¼" dia.

OAL	Order No.
2¾"	CR-275
4"	CR-40
6"	CR-60
8"	CRM-8H
10"	CRM-10H
12"	CRM-12H

Mirrored Safety Glasses

- Wrap-around design • Tinted lenses provide sun glare protection • Universal bridge • Polycarbonate lenses
- Do not use as welders helpers • Great for protecting your eyes when riding your motorcycle too
- Order No. PGL-21



Half-Tapered Cartridge Rolls

- 1½" long, ½" hole
- Fully glued • Box of 50

Dia.	Grit	Order No.
⅜"	40	HTR-375-40
	80	HTR-375-80
½"	40	HTR-500-40
	80	HTR-500-80

Full-Tapered Cartridge Rolls

- 1½" long, ½" hole
- Fully glued • Box of 50

Dia.	Grit	Order No.
⅜"	40	FTR-375-40
	80	FTR-375-80
	120	FTR-375-120
½"	40	FTR-500-40
	60	FTR-500-60
	80	FTR-500-80
¾"	40	FTR-625-40
	80	FTR-625-80

3M® Cross Buffs®

- Aluminum-Oxide
- Box of 10

Dia.	Grit	Order No.
2-Ply		
¾"	V. Fine	CB-75VF
	Med.	CB-75M
1"	V. Fine	CB-1VF
	Med.	CB-1M
1½"	V. Fine	CB-15VF
	Med.	CB-15M
3-Ply		
1¼"	Med.	CB-125M-HD
1½"	V. Fine	CB-15VF-HD
	Med.	CB-15M-HD

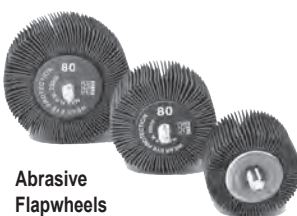

Abrasive Flapwheels

- 1" wide, ¼" x 20 threaded
- Aluminum-Oxide • 1 each

Dia.	Grit	Order No.
1½"	80	APK-7
1"	120	AFW-1-120
2"	120	AFW-2-120
3"	120	AFW-3-120



- Cross Buff® / Flap Wheel Mandrel
- Use with Cross Buffs & Flap Wheels above

Description	Order No.
4" Mandrel	CB-MANDREL
Set Screw (3)	CB-SCREW

NOTE: Extreme caution must be used when porting & polishing. Be sure to wear safety glasses.



"We unload, check and store inventory as efficiently & accurately as possible and we make sure all inventory is accounted for."

— Shane, Goodson Receiving Supervisor, 7 years of service

CYLINDER HEAD
REBUILDING

tech tips
from the techxperts™

Stay Safe:

Always ensure your burr shank is well inserted into your collet and clamped down tightly.

Keep pressure light and keep the burr moving focusing on the highest material first.

Ensure your work is secured tightly to your work bench.

Don't snag or jam your burr into your work.

Wear eye protection as a minimum, but better still, use a full shield for your face.

CLEANING,
ASSEMBLY & SAFETY

SHORT BLOCK
REBUILDING

Double Cut Carbide Rotary Files

FR-34-C



FR-45-C

• 1/4" dia. shank

Dia.	Length	Shank	Order No.
1/2"	1 1/8"	1.1"	FR-34-C
1/4"	1"	1.0"	FR-45-C

CRANKSHAFT/
FLYWHEEL GRINDING

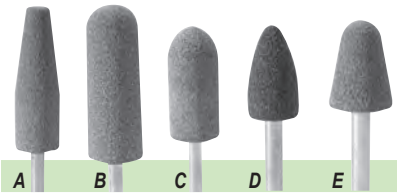

MISCELLANEOUS
TOOLS & SUPPLIES

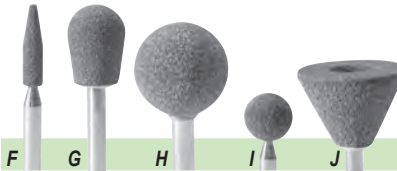

BRAKE SERVICE
TOOLING

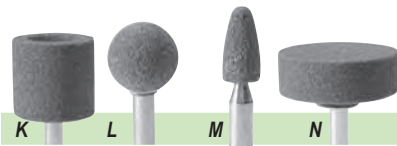

MEASURING
TOOLS

1/4" Shank Mounted Points

• Aluminum-Oxide abrasive is ideal for roughing cast iron • 1 1/2" shank length

Dia.	Length	Grit	Order No.
A 3/4"	2 1/2"	60	GM-1
B 7/8"	2 3/4"	60	GM-3
C 7/8"	1"	60	GM-11
D 1 1/16"	1 1/4"	60	GM-12
E 3/4"	1 1/8"	60	GM-5
F 1/4"	1 1/16"	60	GM-15
G 3/4"	1"	60	GM-23
H 1"	1"	60	GM-25
I 5/8"	3/4"	60	GM-26
J 1 3/8"	1"	60	GM-31
K 1"	1"	60	GM-38
L 3/4"	3/4"	40	GM-40
M 3/8"	3/4"	60	GM-B52
N 1 1/2"	1 1/16"	60	GM-236

V-TWIN & METRIC
HARD PARTS

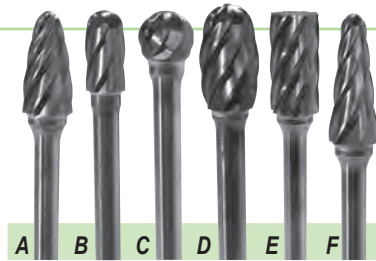

6" Long 1/4" Dia. Shank Open Fluted Rotary Files for Aluminum

- Carbide burrs
- Open flute design gives better chip discharge

	Dia.	Length	Order No.
A	1/2"	1"	LAFR-34
B	3/8"	3/4"	LAFR-45
C	1/2"	7/16"	LAFR-55
D	1/2"	7/8"	LAFR-70
E	1/2"	1"	LAFR-93
F	3/8"	1 1/16"	LAFR-121

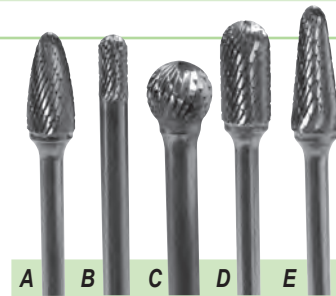

6" Long Shank Double Cut Carbide Rotary Files
• 1/4" diameter shank

Save when you buy the kit!

	Dia.	Length	Order No.	Incl.
Complete 5 Pc. Kit				
			LFR-KIT	▼
A	1/2"	1 1/8"	LFR-34C	x
B	1/4"	1/2"	LFR-45C	x
C	1/2"	1/2"	LFR-55C	x
D	1/2"	1 1/16"	LFR-46C	x
E	1/2"	1 1/16"	LFR-141C	x

V-TWIN & METRIC
HARD PARTS



1/4" Carbide Rotary Files

- Nose design reduces back-gouging
- 1/4" shank • Shanks 4" long except MRT-56C at 6" long



	Dia.	Length	Order No.
A	3/8"	1"	MSH-34C
B	11/32"	7/8"	MSE-44C
C	1/2"	3 1/32"	MRT-54C
D	1/2"	1"	MRT-56C

	Dia.	Length	Order No.
E	1/2"	7/8"	MSE-54C
F	1/2"	1"	MSF-54C
G	1/2"	1 1/2"	MSH-54C



Bifocal Magnifying Safety Glasses

- Safety glasses and cheaters all in one • Anti-fog lenses
- Do not use as welders helpers

Diopter	Order No.
1.00	BSG-100
1.25	BSG-125
1.50	BSG-150



Mirrored Safety Glasses

- Wrap-around design
- Tinted lenses provide sun glare protection
- Universal bridge
- Polycarbonate lenses
- Do not use as welders helpers
- Great motorcycle shades
- Order No. PGL-21

Parts Storage

Dual Overhead Cam Cylinder Head Organizer Tray

- Store valves, springs, retainers, keepers, valve lash adjusters & camshafts • Keep valve lash adjusters from getting mixed up and changing valve adjustment
- Heavy duty construction
- Oil and solvent resistant
- Measures: 23 $\frac{1}{4}$ " x 26 $\frac{1}{2}$ " x 2"H
- Order No. **DOHC-1**

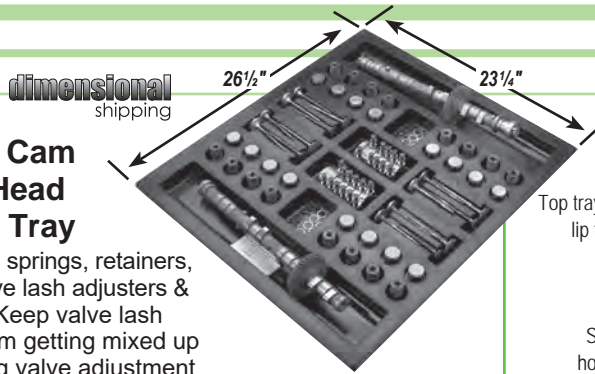

Top tray features 1" deep lip to keep parts from rolling off

Solid steel hangers hold piston rods and crankshafts
Heavy duty casters make moving the engine and cart easy

Engine Storage Cart

- An efficient space-saver
- Heavy-duty casters
- Holds all engine parts off the floor from tear-down to reassembly in less than 4 square feet
- Move the whole engine easily
- Some assembly required
- Order No. **EC-200**

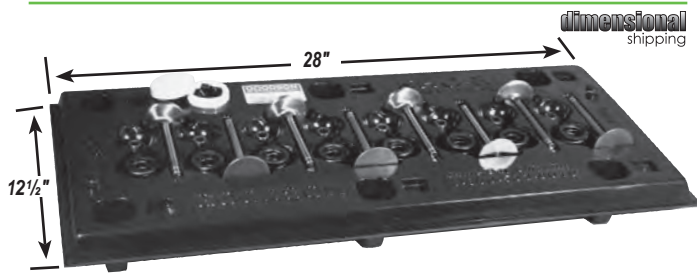
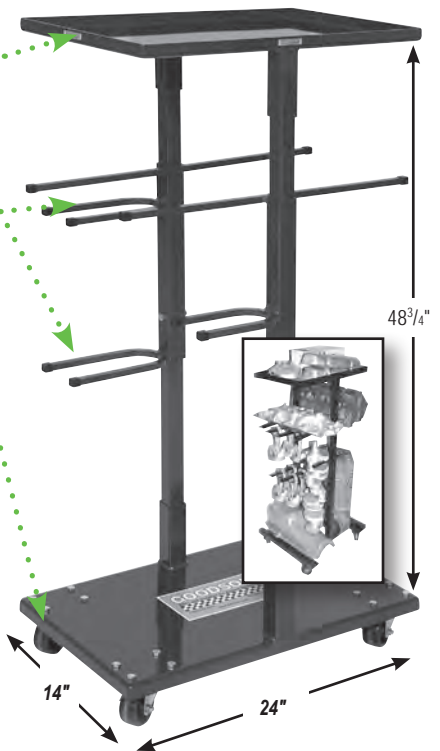

Stackable Cylinder Head Organizer Trays

- Store valves, springs, retainers and keepers in order of assembly • Impervious to oil and most solvents
- Measures 28" x 12 $\frac{1}{2}$ " x 3"H
- Order No. **SHO-8**

Valve Train Tray For 4, 6 or 8-Cylinder OHV Engines

- Heavy duty construction
- Keeps push rods, rockers, lifters, etc. in order
- 64 compartments
- Measures: 11 $\frac{7}{8}$ "W x 23 $\frac{1}{4}$ "L x 1 $\frac{3}{4}$ " H
- Order No. **VTO-80**

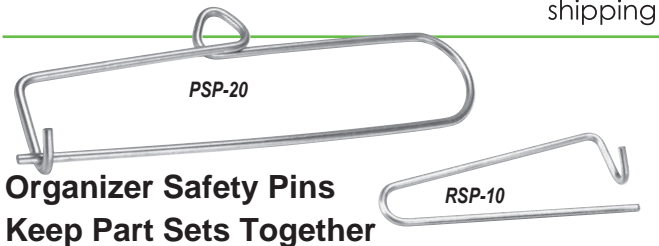
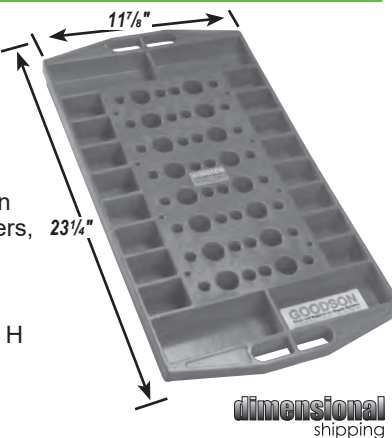

Organizer Safety Pins Keep Part Sets Together

Parts Safety Pin • Organize valve springs, rods, etc., from disassembly to cleaning to reassembly
Rod & Cap Mini Pin • Keep connecting rods & rod caps together to prevent mix-ups

Description	Order No.
Parts Safety Pin (3 $\frac{3}{4}$ " x 12")	PSP-20
Rod & Cap Mini Pin (3 $\frac{1}{4}$ " x 4")	RSP-10

Ford/Chevy Small Block Organizer Tray

- Store pistons, rods, lifters, push rods & camshafts
- Formed compartments keep engine components securely in place
- Measures: 24 $\frac{1}{4}$ " x 25 $\frac{1}{2}$ " x 1 $\frac{1}{2}$ "D
- Order No. **IEO-80**

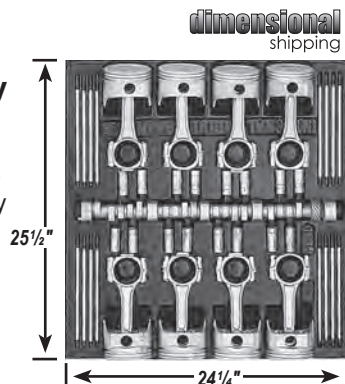

Parts Tags & Marker

- Won't tear or wash off
- Heavy wire ties
- Tough enough to go through a jet wash or hot tank
- Includes 2 Super-Permanent markers with specially formulated ink to withstand most chemicals and extreme heat and steam up to 500°F
- Tag dimensions: 3 $\frac{1}{2}$ "L x 5 $\frac{1}{8}$ "W with 5 $\frac{1}{32}$ " hole for wire tie



Description	Order No.
1000 Parts tags, with 2 markers	IDT-1000
Super-Permanent Marker only	IDT-MARKER

CYLINDER HEAD REBUILDING
CLEANING, ASSEMBLY & SAFETY
SHORT BLOCK REBUILDING
CRANKSHAFT/ FLYWHEEL GRINDING
MISCELLANEOUS TOOLS & SUPPLIES
BRAKE SERVICE TOOLING
MEASURING TOOLS
V-TWIN & METRIC HARD PARTS

... another satisfied customer

"Outstanding customer service; always. Goodson has gone above and beyond to assure we have the tooling we need."

— Jimmy Stray, Metro Motor Center, Houston, TX, Goodson customer since 1990

CYLINDER HEAD REBUILDING

Brass or Steel Shim Stock Assortment Packs

- A handy assortment • 4" x 6" each (120 sq. in.)
- One each of .001", .002", .003", .005", .010" thick

Description	Order No.
Brass	SSB-50
Steel	SSS-51

CLEANING, ASSEMBLY & SAFETY

SHORT BLOCK REBUILDING



Smog Plugs

- Fit Ford 302 & 351
- Replace smog plugs damaged during head cleaning
- 5/8" x 11 thread outside, 7/16" x 14 thread inside
- Order No. **EMP-34**

CRANKSHAFT/ FLYWHEEL GRINDING

MISCELLANEOUS TOOLS & SUPPLIES

Premium Tapered Reamer

- Use by hand or with a powered driver to deburr or enlarge tapered holes for valve guides, bolt hole chamfering and more • Use in 1/2" chuck at approximately 40 RPM for best results • OAL: 5 3/4"
- Flute length: 3 3/4" • Small End: 1/8" dia. • Large End: 1/2" dia.
- Degree of Taper: 2.86° • Hardened and tempered steel with precision ground cutting edges • For steel, brass, aluminum, plastic, wood and more
- Order No. **TR-216-1**

BRAKE SERVICE TOOLING

MEASURING TOOLS

14mm Spark Plug Thread Chaser/Burnisher

- Ideal for cleaning spark plug holes
- Reforms the original material by burnishing, not cutting so no chips are created to be cleaned out
- Order No. **SPB-14**

V-TWIN & METRIC HARD PARTS

Two Blade Spot Facer

- 1 1/4" OD Spot Facer located on 3/8" stud
- Removes unneeded material for easier removal and installation of screw-in studs
- Replaceable carbide blades

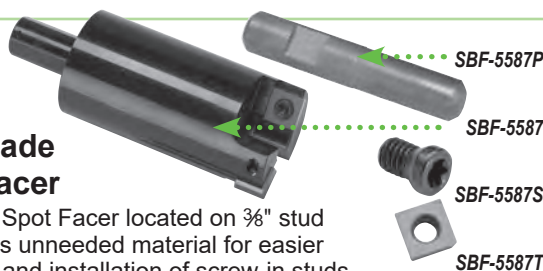

Description	Order No.	Incl.
Stud Boss Facer	SBF-5587	▼
Stud Boss Facer Tip (each) for SBF-5587 only	SBF-5587T	x
Stud Boss Facer Screw (each)	SBF-5587S	x
Replacement Stud Boss Facer 3/8" Pilot (optional)	SBF-5587P	



Head Bolt Spot Facer

- Spot face head bolt seat parallel to new deck surface after angle milling
- Allows proper head bolt torquing
- Cutting tip radius matches OE design to avoid stress points and cracks • .468" shank with flat
- Use with 7/16" Pilot below
- High Speed Steel construction

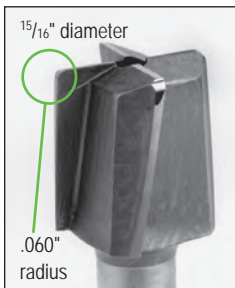

Description	Order No.
Spot Facer	HBF-15
7/16" Pilot	GFP-437

GM Vortec Adaptor Plate Set For Van Norman & Storm-Vulcan Rotary Broaches

- Required when using the Van Norman VN 530 / 570 or Storm-Vulcan 850 Storm-Mill Rotary Broaches
- Two plate set • Includes fasteners
- Order No. **VN-VOR**

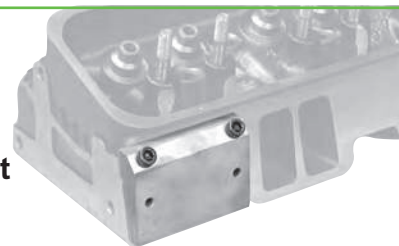

Chevy Conversion Plate Set

- Convert early model, 6-bolt heads for late model, 7-bolt applications
- Works with stock exhaust systems
- Use the standard exhaust manifold gasket or seal with High-Temp Silicone
- Order No. **CHC-10**

Parts Storage & Cleaning

dimensional shipping

Organize, Clean And Store Small Parts With GOODSON Small Parts Baskets

- Galvanized, welded 1/4" mesh
- Can be used with caustics
- Not for use with alkaline or acidic solutions, parts tumblers or shot blasters



Small Basket with Lid

- 2 1/4" dia. x 7" L
- Order No. PWB-2

Medium Basket with Lid

- 4 1/2" dia. x 7" L
- Order No. PWB-4



Single Basket with Handle

- 8.75" OD x 8.5" H
- Lid & clip sold separately
- Order No. PWB-10

Single Basket with Lid, Clip & Handle

- 8.75" OD x 8.5" H
- Order No. PWB-15



Double Basket with Clip

- 8.75" OD
- 17" H
- Hinged on one side
- Order No. PWB-25



Lid & Clip

- For PWB-10
- Order No. PWB-10L

Clip Only

- Order No. PWB-15C

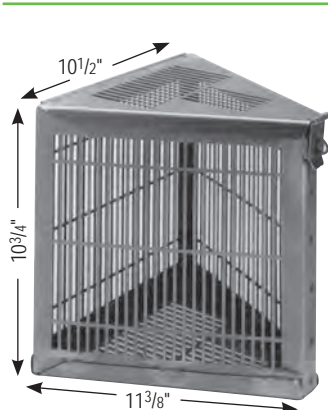

Six baskets fit in 24" diameter

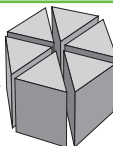

Jet Wash Parts Baskets

- Triangle-shaped • Sit side by side on Jet Wash table
- 6 baskets make a 24" circle
- Fit more baskets in the machine to clean faster
- Order No. JWB-6



Engine & Parts Storage Bags

- Rugged, 3-mil thickness resists tearing
- Engine bags feature 4-mil thickness for extra strength
- Protects your professional work
- Waterproof • Protect finished work from damage
- Jumbo engine bags are extra-strong and big enough to fit complete engines
- Jumbo head bags fit the largest heads
- Ideal for storing heads, cranks, blocks, etc.

Description	Size	Thickness	Qty.	Order No.
Heads, Cranks	16" x 37"	3-mil	100	BC-15
			10	BC-15-10PK
Jumbo Head	17" x 44"	3-mil	100	BC-17
			10	BC-17-10PK
Box-Style	27"x18"x36"	3-mil	50	BE-20
			10	BE-20-10PK
Jumbo Engine (Imprinted)	44" x 52"	4-mil	50	BE-44
			10	BE-44-10PK

Shrink Wrap

- Easy-to-use
- High-clarity film
- Keep machined surfaces clean
- Protects from dirt, dust and moisture
- No need to stock several bag sizes

Size	Order No.
5" x 1000' w/ Extended Core	SW-5
18" x 1500' with 3" core	SW-18



Get the Right Size Gloves

Size Inches
 L 3.5" to 4.0"
 XL 3.9" to 4.4"
 XXL 5.0" to 5.5"



Flock Lined Nitrile Parts Gloves

- Nitrile exterior with diamond grip pattern
- Flock lined • Won't swell • 13" long
- Safe for solvents • Sold as pairs

Size	Order No.
Large	PWG-SOL-L
X-Large	PWG-SOL-XL
XX-Large	PWG-SOL-XXL

CYLINDER HEAD REBUILDING
 CLEANING, ASSEMBLY & SAFETY
 SHORT BLOCK REBUILDING
 FLYWHEEL GRINDING
 CRANKSHAFT/
 MISCELLANEOUS TOOLS & SUPPLIES
 BRAKE SERVICE TOOLING
 MEASURING TOOLS
 V-TWIN & METRIC HARD PARTS



Steel End Brushes

Dia. / Wire gauge / Type	Order No.
Standard Duty	
1/2" .020" crimped	GBC-4
3/4" .020" crimped	GBC-6
1" .020" crimped	GBC-10
1 1/2" .020" crimped	GBC-14
1 3/4" .012" crimped	NH-16
2 3/4" .012" crimped	NH-26
1 3/4" .014" galv. for alum.	ANH-16
2 3/4" .014" galv. for alum.	ANH-26
Ultra Duty (listed left to right)	
1/2" .014" crimped	GBC-4A
1 1/8" .020" knotted, 1 1/4"L	GBC-12
1 1/8" .020" knotted, 7/8"L	GBC-12HD
3/4" .020" knotted	NH-6

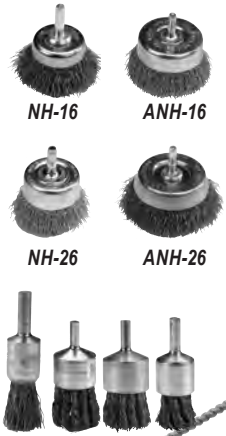

1/4" Shank Steel Brushes

Dia.	Wire Gauge	Grade	Order No.
Deep Well End Brush as brush wears cut back to expose new wire			
1/4"	.012", 6" long	Economy	DEB-1
3/8"	.017", 6" long	Economy	DEB-2
Flare Brush use to remove carbon from engine ports			
1/2" ball, 5/8" cable		Ultra-duty	DEB-3
Port Brush as brush wears cut back spring for new wire			
3/8"	.014", 4" long	Standard	DEB-4
1/2"	.020", 2 1/2" long	Ultra-duty	DEB-5
Cup Brush 5/8"-11 NC - fits standard 4 1/2" angle grinder			
3"	.014" twisted	Ultra-duty	WCB-30
4"	.014" twisted	Ultra-duty	WCB-40

Engine Prep Brushes

Application	Order No.
For small feed hole in block 1/4" x 2" x 10", nylon	OB-1
For Block Oil Return Line 5/16" x 2 1/2" x 12", nylon	OB-2
For Cam & Crank Work 5/16" x 2 1/2" x 12", nylon	OB-2A
For Block Oil Return Lines 3/8" x 2 1/2" x 12", nylon	OB-3
For diesel injector 1 3/4" brush, stainless	DIB-1
For lifter bores 1" x 3" x 14", nylon	LBB-100



Manual Guide Cleaning Brush

- 1/2" Dia. Nylon bristles
- OAL: 8 3/4"
- Order No. **WCB-44**



Round Fiber Parts Brush

- 11" long • Nylon bristles
- Plastic Handle
- Order No. **PCB-348**

Nylon Lifter Bore Brushes

Dia.	Order No.
7/8"	LBB-875
1"	LBB-100
1 1/8"	LBB-1125



Nylon Bristle Oil Gallery Brushes

Steel Wire Oil Gallery Brushes

Desc.	Order No.
5-pc. Kit	OGB-KIT ▼
3-pc. Kit	OGB-SK ▼
1/4" x 3" x 24"	OGB-1 x
3/8" x 3" x 24"	OGB-2 x
5/8" x 3" x 24"	OGB-3 x

Desc.	Order No.
3/8" x 3" x 34"	OGB-38 x
1/2" x 2 1/2" x 34"	OGB-42 x
5/8" x 3" x 34"	OGB-5 x
3/4" x 3" x 34"	OGB-7 x
3/4" x 3" x 40"	OGB-8 x

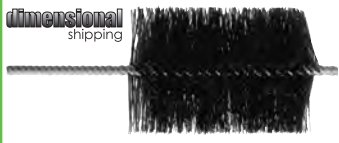

Nylon Bore Washing Brushes

Dia.	Length	Order No.
2"	36"	CBB-200
2 1/4"	36"	CBB-225
2 1/2"	36"	CBB-250
2 3/4"	12"	CWB-27W
3 1/2"	18 1/2"	CWB-35
4"	18 1/2"	CWB-40
4 1/2"	18 1/2"	CWB-45
5"	18 1/2"	CWB-50

Flow Through Parts Washing Brush

- 24" long hose slides over discharge nozzle on parts washer
- Order No. **PWB-FLO-1**



Nylon Pushrod Brush

- Clean the inside diameter of your pushrods with this brush
- Fits pushrods as small as .080" ID
- 12" overall length
- Order No. **PRB-80**

5 Pc. Nylon Valve Guide Brush Set

- Complete set includes 5 popular nylon brush sizes
- From 5/16" to 1/2" dia.
- Order No. **GVP-SET**

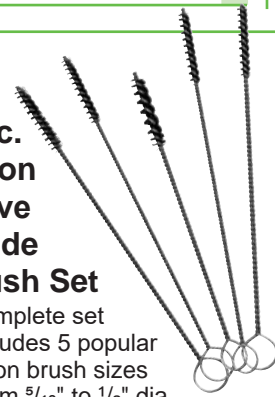

Valve Guide Brushes

Size	Steel Brushes		Nylon Brushes	
	OAL	Order No.	OAL	Order No.
5/16" x 2 1/2"	9 1/2"	GVP-1	12"	GVP-1N
1 1/2" x 2 1/2"	9 1/2"	GVP-2	12"	GVP-2N
3/8" x 2 1/2"	9 1/2"	GVP-3	12"	GVP-3N
7/16" x 2 1/2"	9 1/2"	GVP-4	12"	GVP-4N
1/2" x 2 1/2"	-----	-----	10 1/2"	GVP-5N
9/16" x 2 1/2"	-----	-----	10 1/2"	GVP-6N
3mm x 1 1/4"	-----	-----	8"	GVP-7N
4mm x 1 1/4"	-----	-----	8"	GVP-8N
5mm x 1 1/4"	-----	-----	8"	GVP-9N
6mm x 1 1/4"	8"	GVP-10S	8"	GVP-10N
7mm x 1 1/4"	8"	GVP-11S	8"	GVP-11N



Parts Cleaning



Radial Wire Brushes

- American made oil tempered high carbon steel wire
- High density for faster cleaning and longer life
- Excellent balance • 1/2" - 5/8" arbor

Size	Wire	Duty	Order No.
6" x 1 3/16"	.014" Crimped	Std.	ADA-6
7" x 7/8"	.014" Crimped	Heavy	DA-7
6" x 5/8"	.016" Twisted	Super	TS-6
8" x 3/4"	.016" Twisted	Super	TS-8
6" x 7/16"	.023" Knotted	Ultra	QTC-6

Super Heavy Duty Double-Fill Cylinder Block Washing Brushes

- Highly aggressive
- Long lasting
- .050" Nylon bristles

Diameter	Order No.
4" (101.6mm)	CWB-40DF
4 1/2" (114.3mm)	CWB-45DF

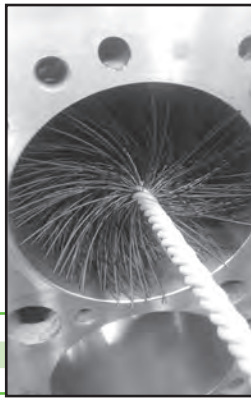

3M™ Roloc™ Bristle Discs

- Effective on cast iron, yet safe for aluminum
- Less aggressive than wire wheels
- Abrasive grains embedded in flexible plastic bristles that break down exposing new grain
- Bristles flex to maintain contact with contoured surfaces for faster, more thorough cleaning
- Use with holders below

Size	Color	Grit	Max. RPM	Order No.
2"	Green	50	25,000	RBD-2G
	Yellow	80	25,000	RBD-2Y
	White	120	25,000	RBD-2W
3"	Green	50	18,000	RBD-3G
	Yellow	80	18,000	RBD-3Y

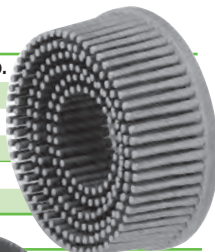

Surface Conditioning Discs

- Use with holders at right
- 10 per box

Dia.	Order No.
2"	Medium RSCD-2M
	Coarse RSCD-2C
3"	Medium RSCD-3M
	Coarse RSCD-3C

Roloc-Type Holders

- Use with Surface Conditioning Discs (left) and Bristle Discs (above)
- Threaded

Size	Order No.
2"	RLH-2
3"	RLH-3

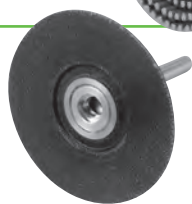
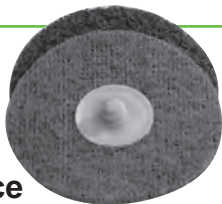

Super Scraper™

- Remove gaskets, carbon, rust, paint, etc.
- Precision-ground solid carbide-tipped, double-edged blade lasts longer than plain steel
- Nickel-chrome 1/8" thick steel shank • For all metals including aluminum



Width	Order No.	Incl.
3 Pc. Set	SS-SET	▼
5/8"	SS-4U625	x
1 1/4"	SS-4U	x
2"	SS-4U2	x

Buy the Kit, SAVE!



Engine Rebuild Brush Kit

- Includes the brushes you'll need for an average engine job
- A great starting place, then add more brushes as you need them • Replacement brushes available

Description	Order No.
Standard Brush Kit - 10 Pc. Kit	BG-KIT ▼
4" Nylon Cylinder Washing Brush	CWB-40 x
1 1/2" Nylon Valve Guide Brush	GVP-2N x
3/8" Nylon Valve Guide Brush	GVP-3N x
Lifter Bore Brush	LBB-100 x
Small Nylon Feed Hole Brush	OB-1 x
Block Oil Return Line Brush	OB-2 x
3/8" Oil Gallery Brush	OGB-38 x
1/2" Oil Gallery Brush	OGB-42 x
5/8" Oil Gallery Brush	OGB-5 x
Round Fiber Parts Brush	PCB-348 x

Low Lint Disposable Assembly Wipes

- Blue, low lint wipes
- Pop-up box
- Hard-wearing
- Tear-resistant
- Ideal for a multitude of uses at the shop, at the track, even at home! • 100 per box
- Order No. AW-100B



CYLINDER HEAD REBUILDING
CLEANING, ASSEMBLY & SAFETY
SHORT BLOCK REBUILDING
CRANKSHAFT/ FLYWHEEL GRINDING
MISCELLANEOUS TOOLS & SUPPLIES
BRAKE SERVICE TOOLING
MEASURING TOOLS
V-TWIN & METRIC HARD PARTS

full service
...fast



"As a small business and employee owner, we wear many hats here at Goodson. Call me for your accounting questions but I'm also trained and knowledgeable to help you with your order!"

- Wendy, Goodson Accounting, 37 years of service

CYLINDER HEAD
REBUILDING



CLEANING,
ASSEMBLY & SAFETY

High Pressure Cleaning System

Aggressively clean oil galleries, lifter bores, cam bearing bores, main bores, cylinder bores and more

- Ergonomically designed pistol grip with easy to reach controls
- Incorporates the aggressive cleaning action of a stainless steel brush with the hydro action of a specially designed water manifold to be used with your shop air to quickly and easily clean the oil gallery holes in gas and diesel engines
- Stainless steel brushes are standard with the kits
- Do **NOT** use with caustics • 110°F max water temp.

SHORT BLOCK
REBUILDING

CRANKSHAFT/
FLYWHEEL GRINDING

Description	Order No.
36" Cleaning Wand Kit	HPOG-1000
36" Cleaning Wand	HPOG-W36
3/8" Stainless Steel Cleaning Brush	HPOG-375
1/2" Stainless Steel Cleaning Brush	HPOG-500
5/8" Stainless Steel Cleaning Brush	HPOG-625
8-32 Thread Adaptor	HPOG-832ADP

Ergonomically designed
billet aluminum grip



Water Pressure
Button - 110°F Max
Air Pressure Button
125PSI Max

Stainless Steel wand will not corrode

Threaded to make
brush changes quick & easy

Air/Water outlet
holes are drilled in a
spiral pattern to create a
swirling motion to enhance
the wand's cleaning power.



Stainless Steel
Brushes

Goodson
exclusive

dimensional
shipping



Scan the code at right with your smart phone or other smart device for fast access to the product video on the Goodson website.



MISCELLANEOUS
TOOLS & SUPPLIES

BRAKE SERVICE
TOOLING

MEASURING
TOOLS

V-TWIN & METRIC
HARD PARTS

Most Powerful



Heavy-Duty UltraSonic Cleaning Detergent

Use **Ultra 1 Cleaner** for: cast aluminum, cast iron, iron, wrought iron, carbon steel, stainless steel, tool steel, carbide, tin, nickel, zinc, cobalt, titanium. Ideal for brackets, clutch housings, axles, engine blocks (cast), nuts, screws

Quantity	Order No
1 gal.	S-U1-1G
2.5 gal.	S-U1-2.5G
5 gal.	S-U1-5G

Moderate- Duty UltraSonic Cleaning Detergent

Use **Ultra 2 Moderate-Duty Cleaner** for: aluminum, billet aluminum, polished aluminum, cast aluminum, cast iron, iron, wrought iron, carbon steel, stainless steel, tool steel, carbide, tin, nickel, zinc, cobalt, titanium, magnesium, gold, silver, copper (requires additive), brass (requires additive), plastic. Ideal for pistons, wheels, brakes, bearings, connectors, crankshafts, valves, connecting rods, shock mounts and cylinder heads

Quantity	Order No
1 gal.	S-U2-1G
2.5 gal.	S-U2-2.5G
5 gal.	S-U2-5G



Least Powerful

Multi- Purpose UltraSonic Cleaning Detergent

Use **Ultra 3 Moderate-Duty Cleaner** for: gold, silver, aluminum, billet aluminum, titanium, platinum, tin, nickel, zinc, cobalt, copper (requires additive), brass (requires additive), plastic. Ideal for pistons, wheels, brakes, bearings, connectors, crankshafts, valves, shock mounts, connecting rods and cylinder heads

Quantity	Order No
1 gal.	S-U3-1G
2.5 gal.	S-U3-2.5G
5 gal.	S-U3-5G



The full line of ULTRASONIC, LLC machines, parts, filters and supplies are available on the Goodson website!

Visit **Goodson.com** to see the full selection today. All ULTRASONIC, LLC items ships directly from the manufacturer. Use your smart phone or smart device to scan the code below for instant access.



Parts Cleaning



Concentrated Defoaming Agent Stops Foaming In Coolants

- For jet washers, air-agitated hot tanks and coolant sumps
- Highly concentrated – start with 1 ounce in 50 gallons

Size	Order No.
8 oz. / 236.6mL	D-FOAM-10
1 gallon / 3.78L	D-FOAM-128

With Rust Inhibitor

Pro Jet Spray Cleaning Powder

- Heavy-duty • Non-caustic
- Penetrates to emulsify encrusted dirt, grease and oil on cast iron & aluminum
- Won't foam excessively
- Additives prevent scale build-up in jet spray components
- Use to maximum 165° F/ 73.9° C
- Mix ratio: 4 oz. powder to 1 gallon of water • pH: 12
- 40 lb. / 18.14 kg pail
- Order No. **PJS-50**



Concentrated Hot Tank Detergent Powders For Cast Iron

- Strong alkaline • pH 12.8
- Removes dirt, heavy oil, grease, carbon, light rust and paint
- Mix ratio 1/2 lb. powder to 1 gal. of water
- 25 lbs.
- Order No. **D-Ci25**



Concentrated Hot Tank Detergent Powders For Non-Ferrous Parts

- Safe on aluminum & sensitive metals, rubber & plastic parts
- Removes heavy grease and oil
- 50 lb. pail • pH: 12.85
- Mix ratio: 1/4 lb. powder to 1 gallon of water
- Order No. **D-AL50**

*Hazardous Goods Fees Apply – Non-Returnable**

*Hazardous Goods Fees Apply – Non-Returnable**

pH Test Strips

- Easy to use • 100 tests per package
- Use the handy guide on the box to determine pH between 0 and 14
- Order No. **HT-PH**



tech tips

from the techxperts™

Pay attention to the mix ratio on cleaning products!

It's important that you start mixing on the weak side and work your way up. An overly strong concentration is just as ineffective as an overly weak mixture. Use pH Test Strips to check the concentration.

Nozzle

Water Shut-Off Valve

Hydro-Air Gun

- Hold by the air supply hose
- Use with hot or cold water
- The grip stays cool even when spraying hot water
- Maintenance free design
- Compact for reaching into tight areas
- Replacement parts available

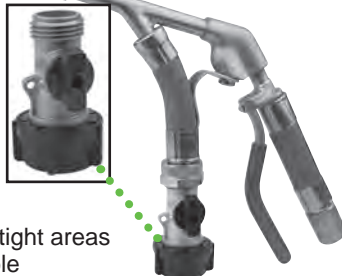

Description	Order No.
Hydro-Air Gun Assembly	BG-150
Replacement Water Shut-off	BG-150W
Replacement Nozzle	BG-150A

Hot Tank Gloves

- One size fits most
- Sold in pairs
- Neoprene fully coated with knit lining and textured grip
- Shoulder length features eyelets & strings at tops to prevent slipping



Description	Order No.
Gauntlet Length (14" long)	HTG-200
Elbow Length (17 1/2" long)	HTG-200E
Shoulder Length (34 3/4" long)	HTG-200L

Full Length Neoprene Shop Apron

- Protects from caustics, steam, grease and oil
- Bib-style • 35" x 45"
- Order No. **HTA-300**

Shown with Shoulder Length Hot Tank Gloves (above)



CYLINDER HEAD REBUILDING
CLEANING, ASSEMBLY & SAFETY
SHORT BLOCK REBUILDING
FLYWHEEL, GRINDING
CRANKSHAFT/ TOOLS & SUPPLIES
MISCELLANEOUS
BRAKE SERVICE TOOLING
MEASURING TOOLS
V-TWIN & METRIC HARD PARTS



"Our easy-to-use catalog features more than 8,000 tools and supplies. Feel free to call if you're not sure what to order or if you have questions. We'll do everything we can to help you get what you need."

-Becky, Goodson Inventory Control, 10 years of service

CYLINDER HEAD
REBUILDING

CLEANING,
ASSEMBLY & SAFETY

SHORT BLOCK
REBUILDING

CRANKSHAFT/
FLYWHEEL GRINDING

MISCELLANEOUS
TOOLS & SUPPLIES

BRAKE SERVICE
TOOLING

MEASURING
TOOLS

V-TWIN & METRIC
HARD PARTS

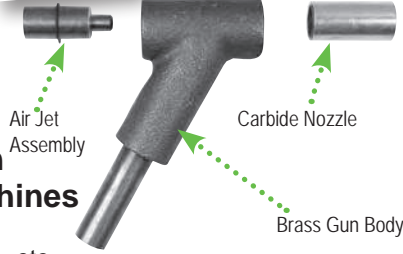

Glass Bead Gun for Smaller Machines

- Solid brass body
- Fits Trinco, Econoline, etc.
- Includes Gun Body, Nozzle and Air Jet Assembly
- Replacement parts available

Description	Order No.
Complete Gun For Smaller Machines	GB-113
Replacement Parts	
Gun body only	GB-111
Carbide nozzle 19.05mm OD, 7.94mm ID	GB-204
Air jet assembly 3.97mm ID, 25 CFM	GB-330

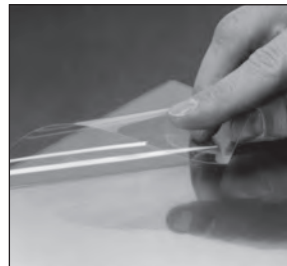

Glass Bead Cabinet Window Film

- Protects the inside of glass bead cabinet windows
- Save time and money – replace the film rather than the glass • 24" x 10' roll
- Order No. **GB-FILM**

tech tips

from the techxperts™
For best results, attach film to cabinet window with ordinary double-faced tape (not included).

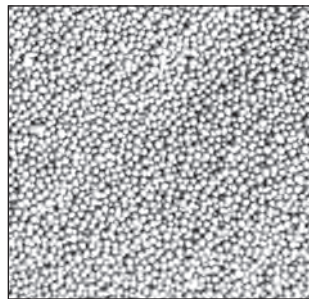

Glass Beads

- Clean parts thoroughly without removing material
- 50 lb. bag • Size #8
- Safe for ferrous & non-ferrous materials
- Order No. **GB-CM**



ARMEX® Maintenance XL Formula Soda Blast Cleaning Media

- 270 micron / 70 Grit Formula
- Use to strip clean almost any car surface including, steel, aluminum, Fibreglas® and plastics
- Ideal for blocks, heads and intake manifolds
- Dissolves in warm water, minimizing particle ingestion that can block fuel lines and passageways
- Won't damage the surface you're cleaning
- Non-toxic and non-hazardous with a pH of 8.2
- 50 lb. / 22.7 kg bags
- Order No. **SMB-170**

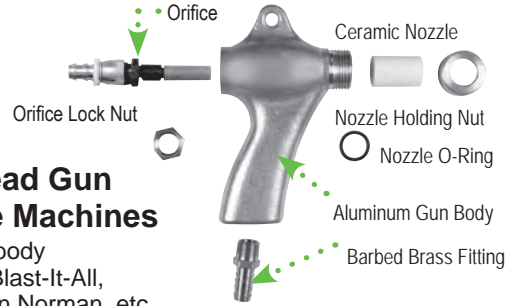

Glass Bead Gun for Large Machines

- Aluminum body
- Fits Zero, Blast-It-All, Winona Van Norman, etc.
- Includes .313" ID ceramic nozzle

Description	Order No.
Complete Gun For Larger Machines	GB-100
Replacement Parts	
Gun body only	GB-101
Barbed Brass fitting	GB-04
Nozzle holding nut (not included in rebuild kit)	GB-54

Rebuild Kits	Order No.	Includes
.250" ID	GB-4-OK	▼
.313" ID	GB-5-OK	▼
.375" ID	GB-6-OK	▼
.437" ID	GB-7-OK	▼
Ceramic Nozzles		
.250" ID	GB-74	x
7/8" OD x 1 3/8"	GB-75	x
.375" ID	GB-76	x
.437" ID	GB-77	x
Replacement Orifices		
#4	GB-64	x
#5	GB-65	x
#6	GB-66	x
#7	GB-67	x
Orifice Lock Nut	GB-52	x x x x
O-Ring	GB-53	x x x x



Glass Bead Gloves

- 30" overall length
- For ports up to 10" diameter
- Durable cloth-lined Neoprene glove with nylon sleeve
- Sleeve design makes attaching glove to your machine, faster and easier • Clamp sold separately

Port Size	Description	Order No.
Up to 8" (20.32 cm)	Single: left-hand glove	GB-654-G
	Single: right-hand glove	GB-655-G
	Pair: one right-hand & one left-hand	GB-660-G
Up to 10" (25.4 cm)	Single: left-hand glove	GB-754-G
	Single: right-hand glove	GB-755-G
	Pair: one right-hand & one left-hand	GB-770-G
8" and 10"	Replacement Clamp: fits both port sizes	GB-CLAMP

SAFETY TIP: NEVER point the Glass Bead Gun at the cabinet window or your co-workers!

Cleaning Media

For Parts Tumblers

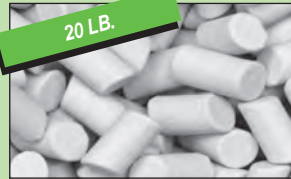

Ceramic Diagonals (20 lb.)
For soft materials such as brass and aluminum. $\frac{5}{16}$ " dia., $\frac{5}{8}$ " long
Order No. **PTM-20CR**



Steel Diagonals (20 lb.)
Ideal for valves.
 $\frac{5}{16}$ " dia., $\frac{5}{8}$ " long
Order No. **PTM-20D**

For Airless Blasters

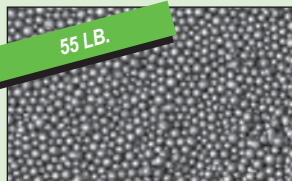

Steel Shot, 170 grade (55 lb.)
Ideal for cleaning cast iron heads.
Diameter varies from .017" to .024".
Order No. **SS-CM** **Jobber**

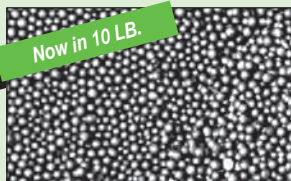

Stainless Steel Shot, Conditioned.
Clean aluminum heads to look like new.
Restores bright aluminum finish. Lasts longer than plain carbon steel shot.
Diameter varies from .006" to .016".
10 lb.
Order No. **SS-CS10**

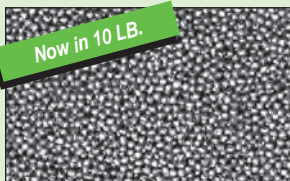

Stainless Steel Cut Wire Shot
Unconditioned. Clean cast iron or aluminum heads before and normalize after welding. Helps prevent surface corrosion after blasting.
.020" Diameter. 10 lb.
Order No. **SS-CW10**



Parts Tumbler Solution

- Dilute 30:1 with water
- For best results, dry parts with compressed air • 1 gallon / 3.78L
- Order No. **PT-SOL**

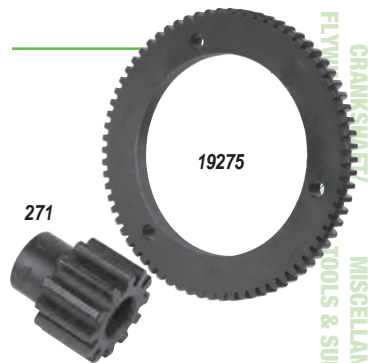

Replacement Gears For Sioux™ 710 Parts Tumbler

- Replaces discontinued Sioux™ parts

Description	Order No.
Steel Gear	271
Fiber Gear	19275



Gauntlet Style Heat & Flame Resistant Gloves

- Heavy lined red terrycloth
- 13½" Long
- Safe to 450°F / 232.2°C
- Order No. **HR-300**



Keeper-Keeper

- Screws tightly closed
- ¼" holes
- Ideal for tumbling keepers
- Solvent resistant PVC
- Order No. **VK-15**

Valve Stem Protectors

- Protects against parts tumbler damage
- Slips on and off easily
- 16 per package
- Order No. **VSP-16**

See Page 135 for Valve Stems

Cloth Shop Apron

- Bib-style apron
- Heavy duty black fabric
- Several handy pockets
- Embroidered Goodson Racing logo
- Machine Washable
- Order No. **CA-100**



Steel Parts Tumbler Basket

- Fits Goodson, K.I., Axe, RMC, and Peterson
- 8" x 12" x 12"
- Order No. **PT-BASKET**



Stay Up-To-Date With Your Friends At Goodson!

We're On Social Media Are You?



Facebook



Instagram



YouTube



Blog

CYLINDER HEAD REBUILDING
CLEANING, ASSEMBLY & SAFETY
SHORT BLOCK REBUILDING
FLYWHEELS
CRANKSHAFTS
MISCELLANEOUS TOOLS & SUPPLIES
BRAKE SERVICE TOOLING
MEASURING TOOLS
V-TWIN & METRIC HARD PARTS



"To improve speed and accuracy we scan every item when pulling and packing orders. Every order is checked first by a person, then by computer before it's shipped to you."
-Tanya, Goodson Shipping, 1 year of service

CYLINDER HEAD
REBUILDING

CLEANING,
ASSEMBLY & SAFETY

SHORT BLOCK
REBUILDING

CRANKSHAFT/
FLYWHEEL GRINDING

MISCELLANEOUS
TOOLS & SUPPLIES

BRAKE SERVICE
TOOLING

MEASURING
TOOLS

V-TWIN & METRIC
HARD PARTS

Last Blast Spray Paint

- Quick-dry formula lets you handle parts in minutes
- Pigment won't smudge AND resist abrasion, corrosion and most solvents
- Paint heads, blocks and parts just like OE
- Withstands heat up to 250°F/121.1°C
- 12 oz. cans
- **Last Blast** restores original look to all types of cast iron
- **Aluminum Last Blast** makes aluminum heads and parts look new
- **Color Last Blast** paint heads and parts in popular, factory colors
- **Hi-Temp Last Blast** Withstands continuous heat up to 1200°F. Heat at 450°F for 1 hour to create a professional, durable finish

Color	Order No.
Cast Iron Gray	LB-1*
Aluminum Gray	ALB-1*
GM Black (Gloss)	CLB-58*
Chevy Orange	CLB-61*
Ford Blue	CLB-60*
Hi-Temp Cast Iron Gray	LB-1-HT*
Hi-Temp Aluminum Gray	ALB-1-HT*
Hi-Temp Black (Matte)	CLB-58-HT*

*Aerosol — Hazardous Goods Fees Apply When Shipped By Air



Industrial Metal Markers

- No shaking needed • Quick dry
- Withstands oil, grease & surface contact • Won't lose its brilliance or legibility
- Medium point



Color	Order No.
Orange	MM-STD
Black	MM-010
Yellow	MM-030
White	MM-050
Green	MM-060
Red	MM-070
Blue	MM-080

Universal Gel Lube

- Sprays on as a liquid and forms into a gel within seconds
- Penetrating formula blends with motor oil
- Multiple uses, including cams, lifters, rocker arms, bearings, pistons/wrist pins, cylinders, valve springs, etc.
- Provides lubrication for engines subjected to prolonged storage before initial start-up
- 8 oz. Aerosol* can
- Order No. **GL-8U**



*Hazardous Goods Fees Will Apply if Shipped By Air

2" Dispensing Pliers for Flexible Tubes

- Maximizes the use of all the material in the tube due to its effective means of application
- Dispenses the thickest sealant through a very small opening, permitting better application control
- Reduces both cleanup time and the possibility of skin contact or other problems caused by excess material squeeze-out
- Order No. **EB-416**



High-Performance Hylomar® Gasket Maker & Thread Sealer

- Maintains seal integrity up to 600°F / 315.5°C
- Polyol-based compound turns from a gel into flexible putty within minutes of application
- Non-hardening formula is impervious to oil, gasoline, glycol and other engine fluids
- Oxygen-sensor safe
- Seals gaps .01" or less
- 100 gram tube
- Order No. **HBS-1**



Assembly & Break-In

Press Fit Lube

- A light coat eases press fit
- Ideal for valve guides, piston pins, cylinder sleeves, etc.
- Eliminates the scoring, gouging and galling of parts during press fitting
- 6 oz. / 177.4mL • Aerosol*
- Order No. **PFL-200**

*Hazardous Goods Fees Apply When Shipped By Air



Press Fit Lubricant

- A light coat eases press fit
- Multiple applications
- Eliminates scoring, gouging and galling of parts during press fitting

Description	Order No.
Aerosol 7 oz. / 207 mL	B-200*
Brush Applicator 200 mL	B-200L

*Hazardous Goods Fees Apply When Shipping By Air



Extreme Pressure Lube

- Withstands pressures up to 50,000 PSI
- Highly refined petroleum product
- Contains no lead, graphite or minerals
- Won't corrode fine surfaces or emulsify with cooling liquids
- Surfaces stay lubed and protected
- In a grease form • 4 fl. oz. / 118.29mL
- Order No. **EPL-4**

Spray Assembly Lube

- Ideal for lubricating parts to ease assembly
- Eliminates critical initial run-in of new and rebuilt high-performance engine components
- Spray on bearings, crankshafts, pistons, rings, etc.
- 11 oz. Aerosol* can • Order No. **SAL-11**

*Hazardous Goods Fees Apply If Shipped By Air



First Lube Engine Assembly Lube

- Prevent dry engine start-ups after long-term storage
- Contains Zinc and Moly
- Clings and forms a slick wall between moving parts
- Withstands start-up pressure
- Compatible with all motor oils

Size	Order No.
8 oz. / 236.6mL	FL-10
1 gallon / 3.78L	FL-128



Blood Friction Master® Engine Assembly Lube

- Contains a low friction additive (PTFE) for dry start-ups
- Ideal for long-term storage
- Forms a slick wall between moving parts
- Clings until dissolved by oil
- Withstands start-up pressure
- Compatible with all motor oils
- Ideal for high performance

Size	Order No.
8 oz./236.6 mL w/brush	AL-22-8
1 gal./3.78 L w/pump	AL-22-10



Need Zinc?

Cam-Shield® Camshaft Assembly Paste

- Provides anti-wear protection for camshafts during break-in
- 2500 parts per million of Zinc
- Use with mechanical and hydraulic camshafts & lifters
- For racing, street, classic, agricultural, diesel & marine camshafts
- 4 oz. / 118.29 mL Brush Top Jar
- Order No. **CSAP-4**



Mr. Race Oil® Engine Assembly Gel

- For all 4-stroke engines!
- An advanced engine assembly gel designed to stay in place for engine protection during storage, shipping and start-up time
- Petroleum based, oil soluble product
- Colored blue so you can see where it's applied
- 8 ounce jar • Order No. **EAG-8**



CYLINDER HEAD REBUILDING
CLEANING, ASSEMBLY & SAFETY
SHORT BLOCK REBUILDING
CRANKSHAFT/ FLYWHEEL GRINDING
MISCELLANEOUS TOOLS & SUPPLIES
BRAKE SERVICE TOOLING
MEASURING TOOLS
V-TWIN & METRIC HARD PARTS

Rust Shield Spray

- 2 formulas to choose from
- **Short Term (Indoor)**
- Non-sticky • Lasts several weeks
- Wipes off with just a towel
- **Long-Term (Outdoor)**
- Thicker than short term
- Protects longer
- Requires a solvent to remove



Formula	Order No.
Short Term	RS-16*
Long Term	RS-16-OD*

*Hazardous Goods Fees Apply When Shipped By Air

Rust Proofing Oil

- 1 Gallon / 3.78 L
- Apply full strength
- Creates a protective film
- Washes off with standard solvents
- Ideal for use with sprayers or can be applied with a brush
- Order No. **RPO-10**



Petroleum Based Rust Inhibitor

- Brush directly from can onto freshly-machined engine components
- Protects iron, steel and aluminum
- Soften with mineral oil to dip small parts
- Order No. **RPC-2A**



Snap Together Adjustable Coolant Hoses

- Hoses hold any shape • Chemical Resistant
- Ideal for most common shop machines

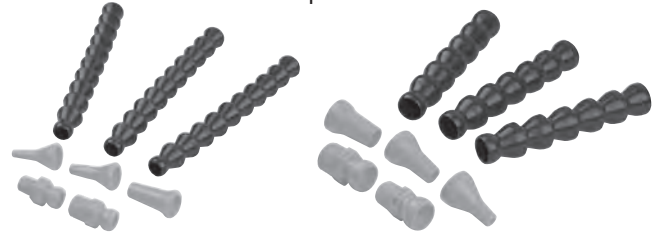

Size: 1/4" Hose Kit
Includes: 18" hose, 1/4" & 1/8" NPT fittings, 1/16", 1/8" & 1/4" round nozzles

Application: Most parts washers, wet-type seat grinders, valve refacers

Order No.: **ACH-400**

Size: 1/2" Hose Kit
Includes: 16 1/2" hose, 3/8" & 1/2" NPT fittings, 1/4", 3/8" & 1/2" round nozzles

Application: Most cylinder hones and flywheel grinders

Order No.: **ACH-600**

Universal Coolant Magnet

- Ideal for Honing Tanks, Flywheel Grinders, Crankshaft Grinders, Head Surfacers and more
- Prevents metal swarf from passing into the coolant tank
- Cut or shape to fit machine bases and return ways
- Measures 3"x48" • Can be trimmed to any size needed
- Order No. **UCM-348**

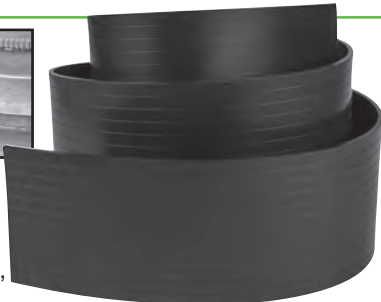

Size: 1" Flare Nozzle for 1/4" Hose

Order No.: **ACH-407**



Size: 1 1/4" Flare Nozzle for 1/2" Hose

Order No.: **ACH-807**

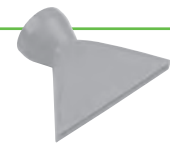

Size: 2 1/2" Flare Nozzle for 1/2" Hose

Order No.: **ACH-809**



NPT	Hose ID	Order No.
1/4"	1/4"	ACH-406
3/8"	1/2"	ACH-804
1/2"	1/2"	ACH-805

Hose ID	Lng.	Order No.
1/4"	11"	ACH-401
1/2"	11"	ACH-801

Coolant & Solvent Pumps

Ideal for Parts Washers

170 Gal. Per Hour Pump

- HP: 1/125
- Capacity: 170 gal/hr. at 1" depth • Hi-temp Seals
- Voltage: 115
- Size: 4" x 3 1/4" x 2 3/4"
- Order No. **COP-166**



Ideal for Flywheel Grinders

1200 Gal. Per Hour Pump

- HP: 1/6
- Capacity: 1200 gal/hr. at 1" depth
- Voltage: 115
- Size: 7 3/4" x 6 1/8" x 4 5/16"
- Order No. **COP-1833**



Sludge Filter Bag

- Fits any machine with a coolant sump
- Replace costly OE filters with this economical, universal sock
- Adds filtration to machines that don't have enough • 8" x 24" polyester knit sock
- Order No. **SB-1**



Machine Lubricants, Etc.

Rust Shield for Shop Equipment

- Stops rust without causing rancidity
- Apply to machine parts
- Mixes with coolant – no need to remove before machining
- 1 Gallon / 3.78 L
- Order No. **RS-128**



Way Oil

- Adhesive oil
- Formulated to provide extended lubrication and rust protection for machine-tool ways
- 1 Gallon / 3.78 L
- Order No. **WO-50**

CYLINDER HEAD
REBUILDING
CLEANING,
ASSEMBLY & SAFETY



Flywheel Grinder Table Lubricant

- Helps extend flywheel grinder life
- High-pressure oil designed to lubricate table bearings and ways
- For all makes of flywheel grinders
- 1 Gallon / 3.78 L
- Order No. **FG-1131-G**

EPL-LS1



EPL-14



EPL-18



10 Quart Engine Pre-Lube Tank Replacement Parts

Description	Order No.
Replacement 8' Hose	EPL-HOSE
LS1 Fitting	EPL-LS1
1/4" Replacement Fitting	EPL-14
1/8" Replacement Fitting	EPL-18
Replacement Gauge	EPL-CG
Mini Ball Valve	EPL-MBV

SHORT BLOCK
REBUILDING
FLYWHEEL, GRINDING
CRANKSHAFT/
GRINDING



Replacement PF Filter Cartridges

- Cartridges remove grit, metal and dirt from honing oil
- Fit Sunnen® CK-10, CV-616, LBB-1810, PF-150 and CH-100 honing machines



Description	Application	Qty.	Order No.
Extra Fine	Oil Only	4 Pk.	PF-105-4
Fine	Oil Only	4 Pk.	PF-110-4
Extra Fine	Water Only	1 Pk.	PF-104
Fine (Fiberglass)	Water Only	1 Pk.	PF-160

1" Thick Rod Hone Filter Mat

- Synthetic material
- Traps abrasive particles & metal filings BEFORE they enter the storage tank
- Cushions parts to prevent damage
- Replace when clogged
- 1" (25.4mm) thick

Inches	Metric	Order No.
18" x 25"	45.7 x 63.5 cm	RH-MAT
26" x 40"	66.0 x 101.6 cm	RH-MAT-2
33" x 48"	83.8 x 121.9 cm	RH-MAT-3

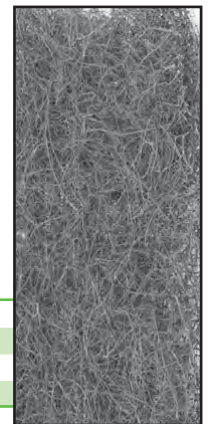

MISCELLANEOUS
TOOLS & SUPPLIES
BRAKE SERVICE
TOOLING

Mfr.	Machine	Capacity
Sunnen	LBB-1699	15 Gal.
	LBB-1660	15 Gal.
	LBB-1810	25 Gal.
	LBB-1803	25 Gal.
	EC-3500	32 Gal.
	ML-3500	32 Gal.
	ML-5000	32 Gal.
	ML-2000	28 Gal.
	CK-10	55 Gal.
	CV-616	55 Gal.
	SV-10	55 Gal.
CK-21	63.5 Gal.	

Mfr.	Machine	Capacity
Rottler	H85AXY	70 Gal.
	H85A	70 Gal.
	H85AX	70 Gal.
	H86A	70 Gal.
	H86AX	70 Gal.
	H86AXY	70 Gal.

tech tips
from the techxperts™

Hone Cabinet Filter Paper

- Reduce sump and filter clean-up
- Extend oil life
- Filter paper in the bottom of hone machine removes debris before oil enters the sump
- When full, dispose of properly
- 2 – 60" x 60" sheets (trim to fit)
- Order No. **HN-FP**

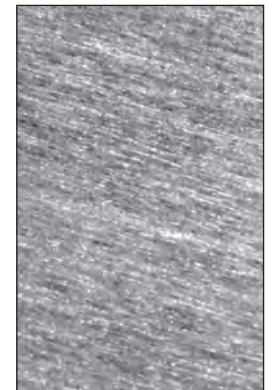

MEASURING
TOOLS
V-TWIN & METRIC
HARD PARTS



Coolants and Lubricants

We don't stock one type of coolant and claim that it suits all types of grinding, nor do we carry one type of oil and try to sell it for every application. Each of our coolants, lubricants and oils is formulated to deliver better results and longevity in its specific use. All of our coolants prolong the life of grinding wheels, retard corrosion and rancidity. Colors may vary. **Note: Dilution ratio is water to coolant.**

Grinding Coolants

All-Purpose Grinding Coolant

A synthetic water soluble coolant that "Licks Rust". Dilute 30:1

Size	Yield	Order No.
1 gal.(3.78L)	30 gallons	CGC-1288

Crank & Cam Grinding Coolant

Synthetic, non-nitrate, high lubricity coolant. Dilute 20:1

Size	Yield	Order No.
1 gal.(3.78L)	20 gallons	CGC-10
5 gal.(18.9L)	100 gallons	CGC-50

Multi-Duty Grinding Coolant

Medium-duty, low foaming, synthetic coolant with rust inhibitors. Safe for ferrous and non-ferrous metals alike. No nitrates, phenols, chlorine or sulfur. Dilute 30:1

Size	Yield	Order No.
1 gal.(3.78L)	30 gallons	GPC-10
5 gal.(18.9L)	150 gallons	GPC-50

Belt-Resurfacing Coolant

For all belt-type resurfacers with or without down-pressure. Dilute 30:1

Size	Yield	Order No.
1 gal.(3.78L)	30 gallons	SGB-10
5 gal.(18.9L)	150 gallons	SGB-50

Surface Grinding Coolant

Non-foaming, non-nitrate coolant for single-piece resurfacing wheels or segments. Dilute 20:1

Size	Yield	Order No.
1 gal.(3.78L)	20 gallons	SGC-10
5 gal.(18.9L)	100 gallons	SGC-50

Flywheel Grinding Coolant

Includes a synthetic rust inhibitor that prevents rancidity. For all flywheel grinders. Dilute 30:1

Size	Yield	Order No.
1 gal.(3.78L)	30 gallons	FG-1101-G
5 gal.(18.9L)	150 gallons	FG-1102-G

Grinding & Honing Oils (Not Water Soluble)

Cylinder Honing Oil (Clear)

Ideal for portable hones and all makes of automotive honing machines. Mixes readily with other brands (including Sunnen®).

Size	Order No.
1 gal.(3.78L)	HO-10
5 gal.(18.9L)	HO-50



Sunnen® Mineral Based Honing Oil

Formulated for general purpose automotive machine shop honing. Compatible with most popular honing machines.

Size	Order No.
5 gal. (18.9L)	MAN-845



Valve Grinding Oil (Light Yellow)

Universal valve grinding oil extends wheel life. Mineral based. Prevents rancidity, foaming & deposits.

Size	Order No.
1 gal.(3.78L)	VGO-10
5 gal.(18.9L)	VGO-50



Rod Honing Oil (Dark Brown)

Keeps stones clean & free-cutting during rod reconditioning, pin fitting and other honing jobs. Will mix with other brands (including Sunnen®).

Size	Order No.
1 gal.(3.78L)	RHO-10
5 gal.(18.9L)	RHO-50



Sunnen® Honing Oil Concentrate

Formulated for general purpose automotive machine shop honing. Compatible with most popular honing machines. Add your own Mineral Oil. Mix Ratio: 10:1 for MAN-845 or 2:1 for MB-30

NOTE: Cannot be shipped to California

Size	Order No.
5 gal. (18.9L)	MAN-C



Severe Duty Valve Grinding Oil (Brown)

For grinding titanium, Inconel®, stainless steel and stellite valves. Includes additives to improve cutting performance under pressure.

Size	Order No.
1 gal.(3.78L)	VGO-SD10
5 gal.(18.9L)	VGO-SD50



Diamond Honing Oil (Brown)

Specially formulated to withstand the cutting pressures created when using our Diamond Valve Guide Honing System.

Size	Order No.
8 oz.(236.6mL)	DHO-8
1 gal.(3.78L)	DHO-10
5 gal.(18.9L)	DHO-50



Sunnen® Mineral Based Multi-Purpose Honing Oil

High performance lubricity agents with sulfur extreme-pressure additives. Won't weld or tear the work-piece.

For metals from aluminum to zirconium

Size	Order No.
5 gal. (18.9L)	MB-30



Titanium Valve Grinding Aid

Mix ratio of 1:4. Add to mineral based valve grinding oils. Improves finish on titanium, stainless steel and stellite valves.

Size	Order No.
32 oz.(946.6mL)	VGA-T32



Water Based

Diamond Honing Coolant

Suitable for diamond honing on cast iron blocks. Greatly reduces heat build-up in the block. Reduces amount of block cleaning needed after honing

Size	Order No.
5 gal.(18.9L)	DHC-50



Sunnen® Water Based

Honing Coolant Concentrate for Cast Iron

Meets the demands of Single-Stroke and metal-bond Superabrasive honing. Ideal for honing aluminum or with diamond plated tools. Can be used as a general grinding coolant. 5 gallons makes up to 55 gallons of coolant. Mix ratio: 10:1.

Size	Order No.
5 gal.(18.9L)	SCC750005



Need a Safety Data Sheet or Product Instructions?

Look on the Goodson website for SDS and Product Instructions. If you can't find what you need, give us a call.

3-D Fast Cut™

3-D Fast Cut™ Starter Kits	6, 7
Ball Head Drive Adaptors	6, 7
Bounce Springs	6, 7
Bowl Profiler	12
Lift Clip	6, 12
Micro Ball Head Tooling	7, 12
Pilots	3 - 5
Setting Micrometer	7
Tool Setting Fixture	6, 7
Universal Spring Pad Cutters	12
Valve Seat Cutter Blades	8 - 11
Valve Seat Cutter Tool Holder	6, 7
Valve Seat Removal Tooling	7

A

Abrasive Belt Dresser	107
------------------------------------	-----

Abrasives

Aluminum Oxide Cloth Shop Rolls	59
Belts	49, 108, 109
Bench Grinder Wheels	116
Blanchard Grinder Wheels	51
Brake Drum Grinding Wheels	122
Brake Shoe Grinding Sleeves	118
Cam Grinding Wheels	101
Cartridge Rolls	58, 59
CBN Inserts for Cast Iron	48
Chamfering Cones	46, 89
Crankshaft Grinding Wheels	102, 103
Crankshaft Polishing Belts	108, 109
Crocus Cloth	59
Cross Buffs®	58, 59
Cylinder Head Resurfacing	48 - 51
Cylinder Honing	86 - 92
Diamond Honing	32
Diesel Super Abrasive Insert	48
Discs	59, 65
Flapwheels	58, 59
Flex-Hones®	34, 83, 89, 101, 122
Flywheel	112 - 113
Grinding Discs	59, 65
Grinding Wheels	26, 27, 51, 91, 101-103, 116
Grinding Stones	18 - 23, 112, 113
Honing	32, 34, 83, 86 - 92
Hyper-Finish Diamond Honing	32
Lifter Bore Honing	99
Mounted Points	1, 58, 60
PCD Inserts for Aluminum	48
Rod & Cap Grinding Wheels	91
Rod Honing / Pin Fitting	90 - 91
Sleeves	58, 118
Ultra-Finish Plateau Honing	36, 88, 92
Valve Guide Honing	32, 34
Valve Refacing	25 - 27
Valve Seat	18 - 23

Accu-Turn

Replacement Cutting Tips	117
Replacement Parts	122

Adjustable Coolant Hoses	72
---------------------------------------	----

Adjustable Counterbore Cutter Kit	15
--	----

Air Tools	17, 35, 36, 42, 43, 45
------------------------	------------------------

Align Hone Mandrels & Stones	92
All Tool Brake Lathe Replacement Tips	117
Aluminum Last Blast	70
Alumni-Chek	53
Ammco	
Belts, Drive	121
Brake Lathe Arbor	120
Brake Lathe Cutting Tips	117
Replacement Parts	118 - 122
Aprons	67, 69, 136
Arbor Nuts	120
Arbors	120
Assembly Lubes	70, 71
Assembly Wipes	65

B

Bags	63
Balancing Scales	97
Ball Head Seat Cutter Driver	6, 7
Ball Hones	34, 83, 89, 101, 122
Band Ring Compressors	95
Baskets	63, 69
Beehive Springs	131, 132
Beeswax	98
Bean Brake Lathe Replacement Tips	117
Bearing Scraper	100
Bell Clamps	121
Belt Dressers	107
Belts	
Crankshaft Polishing	108, 109
Cylinder Head Resurfacing	49
Kwik-Way Valve Refacer Belts	28
Made-to-Order	106
Oil Pump Belts	29, 90
Rod Honing Belts (for Sunnen)	29, 90
Sioux Replacement Belts	28
Sunnen® Honing Machine Belts	29, 90
Surface Grinding Belts	49
Bench Grinder Wheels	116
Bifocal Safety Glasses	60

Black & Decker

Adaptor for Sioux Stones	22
Replacement Collet	28
Stone Holders & Accessories	22
Valve Refacer Wheels	26

Black Diamond Valves	135
-----------------------------------	-----

Black Diamond Valve Guide Sizing	32
---	----

Black Light	53, 116
--------------------------	---------

Black Smoke Series Cutters	11
---	----

Blanchard Grinder Wheel	51
--------------------------------------	----

Block Bags	63
-------------------------	----

Blood Friction Master® Assembly Lube	71
---	----

Bluing Fluid	13
---------------------------	----

Bore Gauges & Setting Fixtures	125, 126
---	----------

Boring Bar Cutters/Accessories	84, 85
---	--------

Bounce Springs	6, 7, 24
-----------------------------	----------

Bowl Profiler Tooling & Blades	12
---	----

Brake Drum Grinding Wheels	122
---	-----

Brake Flex-Hones®	122
--------------------------------	-----

Brake Lathe	
--------------------	--

Arbors	120
--------------	-----

Bits	117
------------	-----

Brake Lathe (cont.)

Centering Cones	121
Cross Feed Shear Gear	120
Cutting Tips	117
Drum Feed Screws & Bushings	120, 122
Dust Boots	122
Feed Motor	120
Flexible Arbor Spacers	120
Lead Screw Bushing	118, 120, 121
Locking Knob	120
Mounting Adaptors	121
Replacement Parts	120 - 122
Rotor Feed Screws	120 - 122
Seals	120
Serpentine Drive Belts	121
Silencer Bands	119
Spindle Boots	122
Switches	120
Tip Holders	118
Tips	117
Wear Inserts, Brass	120

Brake Lubes	121
--------------------------	-----

Brake Shoe Grinding Sleeves	118
--	-----

Brass Shim Stock	62
-------------------------------	----

Brass Wear Inserts	120
---------------------------------	-----

Brazed Carbide Cutting Tools	118
---	-----

Break-In Lubes	71
-----------------------------	----

Bronze Liners & Tooling	38, 39
--	--------

Bronze Reaming Oil	31, 37
---------------------------------	--------

Brushes	32, 34, 38, 47, 64, 65, 66, 98, 99, 101
----------------------	---

Bucket Lifter Grinder	45
------------------------------------	----

Burets and Stands	47
--------------------------------	----

Burr Buster	116
--------------------------	-----

Burrs, Carbide	60
-----------------------------	----

Bushing Press Kit, Tapered Pin	94
---	----

C

Calipers	126, 127
-----------------------	----------

Cam-Shield®	71
--------------------------	----

Camshaft Work

Cam Bearing Tools	100, 101
Cam Bore Washing Brushes	64, 101
Cam Wheels	101
Flex-Hones®	83, 101

Carbide

Brake Tips	84, 117
Burrs (Rotary Files)	60
Cutters	8 - 11, 15, 33, 48, 62, 84, 85
Glass Bead Nozzles	68
Pilots	5
Reamers	31
Resurfacing Tips	48
Rotary Files	60
Sizing Balls	38, 39
Spot Facers / Top Cutters	33
Valve Spring Seat Cutters	46

Cap Grinding Wheels	91
----------------------------------	----

Cartridge Rolls	58, 59
------------------------------	--------

CBN Cutter Inserts	48
---------------------------------	----

CBN Dressing Stick	113
---------------------------------	-----

CBN Flywheel Stones	113
----------------------------------	-----

CC-ing Equipment	47
-------------------------------	----

Index

- CC-ing Liquid Concentrate** 47
- Centering Cones, 60°** 38
- Ceramlub™** 121
- Chamfer Tools** 33, 39
- Chamfering Cones** 46, 89
- Chevrolet**
- Block Organizer Tray 61
 - Conversion Plate 62
- Clamp-On Brake Lathe Silencers** 119
- Cleaning Supplies**
- Aprons 69, 136
 - Baskets 63, 69
 - Brushes .. 32, 34, 38, 47, 64 - 66, 98, 99, 101
 - Cleaning Media 69
 - De-foaming Agent 67
 - Detergents 67
 - Glass Beads 68
 - Gloves 63, 67 - 69
 - Parts Tumbler Solution 69
 - Pro-Jet Spray Cleaning Powder 67
 - Roloc Bristle Discs 65
 - Safety Gear 59, 60, 63, 67, 69
 - Scrapers 65, 100
 - Shop Towels 65
 - Sludge Filter Bag 72
 - Soda Blast 68
 - Ultrasonic Detergents & Filters 66
- Clover Lapping Compound** 17, 111
- Collets**
- Black & Decker 28
 - Dowel Puller 111
 - Expanding Pilots 4
 - Valve Grinding 25
- Combustion Chamber Measuring** 47
- Compression Release Valves** 130
- Concentricity Gauges** 13, 25
- Connecting Rod Heaters** 95
- Cold Chisel** 104
- Coolant Filters** 73
- Coolant Hoses** 72
- Coolants, Lubricants & Oils**
- All-Purpose Grinding Coolant 74
 - Aluminum Machining Aid 59
 - Belt Resurfacer Coolant 49, 74
 - Blood Friction Master 71
 - Brake Lubes 121
 - Bronze Reaming Oil 31, 37
 - Cam-Shield® Assembly Lube 71
 - Crank & Cam Grinding Coolant 74, 101
 - Cutting and Tapping Fluid 13, 55
 - Cylinder Honing Oil 74, 85
 - Diamond Honing Oil 33, 74, 85
 - Engine Assembly Gel 71
 - Extreme Pressure Lube 71
 - First Lube 71
 - Flywheel Grinding Coolant 74, 110
 - Flywheel Grinder Table Lubricant 73, 110
 - Gasket Maker / Thread Sealer 70
 - Gel Lube 46, 70
 - High Performance Resurfacing Spray 48
 - High Performance Valve Grinding Aid 25, 74
 - Honing Oil Concentrate 74
- Coolants, Lubricants & Oils (cont.)**
- Hylomar® 70
 - Knurlube 37
 - Lapping Oil 59, 85
 - Magnetic Crack Detection Oil 53
 - Mineral Based Honing Oil 74, 85
 - Minnesota Fast Freeze 12, 17
 - Multi-Duty Grinding Coolant 74
 - Petroleum Based Rust Prevention 72
 - Porting & Polishing Machining Aid 59
 - Plate Lube 54
 - Press Fit Lubricant 12, 71, 94
 - Rod Honing Oil 74, 88, 90
 - Rust Inhibitor for Pressure Tester 56
 - Rust Proofing Oil 72
 - Rust Shield 72, 73
 - Seat Cutting Fluid 14
 - Spray Assembly Lube 71
 - Surface Grinding Coolant 50, 74
 - Titanium Valve Grinding Aid 25, 74
 - Universal Gel Lube 46, 70
 - Valve Grinding Oil 27, 74
 - Valve Seat Machining Aid 13
 - Water Based Diamond Coolant 74, 85
 - Way Oil 73
- Coolant Magnet** 72
- Coolant Pumps** 72
- Core Drills / Reamers** 30
- Counterbore Cutters** 8-11, 15
- Crack Detection and Repair**
- Additives 56
 - Alumni-Chek 53
 - Applicators 52
 - Ceramic Motor Seal 56
 - Fluid Weld® 56
 - Goodson Glow 53
 - Heat Tabs 56
 - Magnetic Crack Detection Oil 53
 - Magnetic Field Indicator 52
 - Magnetic Powder 52
 - Parker Magnetic Crack Detection Unit 52
 - Powder 52
 - Repair Kit 55
 - Seal-All™ 56
 - Small Parts Demagnetizer 52
 - Threaded Plugs, Ironite® 55
 - UV Inspection Light 53, 116
- Crankshaft**
- Bearing Scraper 100
 - Crank Grinding Wheels 102, 103
 - Crank Welding Plug Rods 106
 - Dial Indicator, Starrett 104, 127
 - Diamond Dresser Tools 115
 - Display Inspection Stand 57, 101
 - Eliptibur Tool 105
 - Grinding Coolant 74, 101
 - Journal Radius Gauge 104
 - Peening Tool 105
 - Plastigage 106
 - Polishers 107
 - Polishing Accessories 107
- Crankshaft (cont.)**
- Polishing Belts 1, 108, 109
 - Polisher Motor 107
 - Reluctor Ring Installation Tool 105
 - Steady Rest Shoes 105
 - Steel Stamps 106
 - Stroke Checker 106
 - Stroker Mimic™ 105
- Crocus Cloth** 59
- Cross-Buffs®** 58, 59
- Cross Feed Dust Boots** 122
- Cross Feed Shear Gear** 120
- CSS Ultra Grinding Wheels** 102, 103
- Cummins Tooling** 11, 30, 35, 40
- Cutter Drivers & Adaptors** 15
- Cutting & Tapping Fluid** 13, 55
- Cylinder Block Work**
- Automotive Dowel Puller & Collets 111
 - Bore Washing Brushes 64, 65, 101
 - Deck Bridge Combination Tool 127
 - Lifting Sling 100
 - Oil Gallery Brushes 64, 98
 - Oil Gallery Plugs & Tools 98
- Cylinder Head CC-ing Equipment** 47
- Cylinder Head Resurfacing**
- Belt Resurfacer Coolant 49, 74
 - CBN Cutter Inserts 48
 - Dressers 51
 - Grind Aid 107
 - High Performance Resurfacing Spray 48
 - PCD Inserts for Aluminum 48
 - Rotary Broach Tool Bit 48
 - Segments 50
 - Surfacing Belts 49
 - Surfacing Wheels 51
- Cylinder Honing**
- Chamfering Cones and Mandrels 89
 - Goodson 86 - 88
 - Honing Oil 74, 85
 - Keyway Honing Stones 88
 - Lisle® 89
 - Nicasil 89
 - Plateau Honing 88, 92
 - Portable Cylinder Hones 86
 - Stones 86 - 90
 - Sunnen® 86 - 90

D

- D-Foam** 67
- David Vizard Porting Kit** 1
- Deburring Tools** 94, 116
- Deck Stand** 127
- Degree Wheel** 100
- Demagnetizer** 52
- Depth Gauge, Flywheel** 110
- Desmond Style Dressers** 51, 110, 116
- Detergents** 67
- Dial Bore Gauge Setting Fixtures** 125
- Dial Bore Gauges** 125, 126
- Dial Calipers** 126, 127
- Dial Indicators** 104, 127
- Diamond Dresser Tools** 29, 91, 114, 115
- Diamond Hand Files** 9

Index

Diamond Flex-Hones® 83
Diamond Guide Hone Tools 32
Diamond Honing Oil 33, 74, 85
Die Grinding Stones 1, 58, 60
Diesel
Core Drills & Reamers 30
Guide Tooling 30 - 40
Heat Tabs 56
Relief Tooling 11
Seat Installers 17
Spring Compressor 42
Super Abrasive 48
Valve Guide Tooling 30 - 40
Valve Guides 30, 37
Valve Seals 30, 40
Valve Seat Cutter Blades 8 - 11
Dingleberry Hones 34, 83, 89, 101, 122
Disposable Assembly Wipes 65
Distributor Depth Gauge 124
DOHC Organizer Tray 61
Double Angle Valve Seat Wheels 20
Dowel Puller & Collets 111
Dressers
Abrasive Belt Dresser 107
CBN Dressing Stick 113
Cutter Assemblies 51, 110
Desmond-Style Dressers 51, 110, 116
Diamond Stone Dresser 91
Flywheel Stone Dressers 110, 115
Hand-Held Dressing Sticks 104
Premium Diamond Dressers 29, 114, 115
Refacing Grinding Wheel Dressers 29
Star Dressers 51, 110
Valve Seat Wheel Dressing Stands 24
Dressing Stand Pilots 5, 24
Drive Adaptors 6, 15
Dykem® Layout Fluid 13

E

Eliptibur Tool 105
Engine Assembly Gel 71
Engine Brush Kit 65
Engine Cart 61
Engine Pre-Lube Supplies 70 - 73
Electric Rod Heater 95
Epoxy, Porting 58
Expanding Pilots 4
Extended Length Pilots (.375" Top) 4
Extreme Pressure Lube 71

F

False Guides 37, 134
Fast Freeze 12, 17
Feeler Gauges 123
File, Diamond 9
Filter Bag 72
Filter Inspection Tool 98
Filter Paper & Mats 73

Filters
Hone 73
Inline Air Filter 54, 55
First Lube 71
Flapwheels 1, 58, 59
Flex-Hones® 34, 83, 89, 101, 122
Fluid Weld® 56
Flywheel Grinding
Bolt Adaptors 110
CBN Flywheel Stones 113
Coolant 74, 110
Dowel Puller & Collets 111
Depth Gauge 110
Dressers 110
Grinding Stones 112, 113
Mounting Adaptors 112
Flywheel Step Gauge 110
FMC
Brake Lathe Replacement Parts 122
Brake Lathe Replacement Tips 117
Ford
Core Drills & Reamers 30
Diesel Seat Cutter Blades 11
Smog Plugs 62
Valve Guides 37
Formula One Boring Tools 85

G

Gas Porting Tools 94
Gasket Maker 70
Gauges
Concentricity Gauge 25
Crankshaft Journal Radius Gauge 104
Distributor Depth Gauge 124
Dial Bore Gauges 125, 126
Feeler Gauges 123
Flywheel Depth Gauge 110
Magnetic Field Gauge 52
Rod Bolt Stretch Gauge 96, 123
Small Hole Gauge Set 39, 123
Split Ball Bore Gauge 39, 123
Spring Tester Height Indicator 40
Sunnens AG-Gauge 124
Telescoping Gauge Set 123
Torque Angle Indicator 57
Vacuum Tester Gauge 54
Valve Guide Gauge Set 124
Valve Seat Height Gauge 24, 126
Valve Seat Run-Out Gauges 13
Valve Stem Height Gauges 46
Warp Gauges 123
Gel Lube 46, 70
General Motors (GM)
Oil Pickup Tube Driver 98
Reluctor Ring Installation Tool 105
Vortec Adaptor Plate Set 62
Glass Beading Supplies 68
Glasses, Safety 59, 60, 111

Gloves
Glass Bead 68
Heat & Flame Resistant 69, 95
Hot Tank Gloves 67
Nitrile 63
Parts Washing Gloves 63
Grind Aid 107
Grinding Stones & Wheels (see Abrasives)
Guide Installers (Drivers) 35
Guide Knurling
Knurling Arbors 37
Knurlube 37
OD Knurling Tool 37
Guide Liners 39
Guide Shoes 88 - 90
Guide Tooling, Diesel 30 - 40
Guides 30, 37, 134

H

Harley-Davidson® (see V-Twin)
Head Bags 63
Head Bolt Spot Facer 62
Head Holders 47, 57
Head Organizer Trays 61
Heat Tabs 56
Heavy Metal 111
Height Gauges 24, 46, 126
High Performance
Cam Wheels 101
CC-ing Equipment 47
Gasket Maker & Thread Sealer 70
Resurfacing Spray 48
Valve Grinding Aid 25, 74
Valve Seat Cutter Blades 8 - 9
Valve Spring Booster Shims 47
Valve Spring Compressors 42 - 44, 129
Valve Spring Testers 1, 41
Valve Train Checking Springs 46
High Pressure Cleaning System 66
Hi-Temp Last Blast Paint 70
Honing Oil 74, 85
Honing Stones
Cylinder Honing 86 - 92
Lifter Bore 99
Pin Fitting 91
Rod Honing 90, 91
Valve Guide 32, 34
Hoses 42, 54, 72, 73
Hot Tank Detergents 67
Hylomar® Gasket Maker & Solvent 70
Hyper Finish Diamond Guide Sizing 32, 33

I

ID Tags 61
IDL Valve Refacer Wheels 26
Import Head Stud Stretchers 50
Inspection Lights 53, 116
Inspection Stand 57, 101
Indicators 24, 40, 45, 46, 54, 57, 104, 110, 127
Infinite Flow Cutting Tips (IFT) 8

Index

Intake Port Reshaping Kit	58	
Iron-tite	55, 56	
J		
Jet Spray Cleaning Powder	67	
Jet Valve Eliminator Kit	55	
Jet Washer Parts Baskets	69	
K		
Keeper-Keeper	69	
Keeper Tools	44, 129	
Keyway Honing Stones	88	
Knurling	37	
Knurlube	37	
KO Lee Valve Refacer Wheels	26	
Kwik-Way		
Belts	28, 49	
Boring Bar Cutters	84, 85	
Brake Lathe Tips	117	
Drive Adaptor	19, 22	
Expanding Pilots	4	
Heavy Duty Dressing Stand	24	
Rebuild Kit for KW Holders	22	
Resurfacer Wheel Segments	50	
Single-piece Resurfacer Wheels	51	
Solid Tapered Pilots	3	
Stone Holders	22	
Valve Refacer Replacement Parts	28	
Valve Refacer Wheels	26	
Valve Seat Grinder Motors	19	
Valve Seat Stones	18	
L		
Lapping Compound	17, 111	
Lapping Oil	59, 85	
Lapping Tools & Compound	16, 17, 111	
Last Blast Paint	70	
Layout Fluids	13	
Letter Stamps	106	
Levels & Vials	7, 48	
Lifter Bore Tools	99	
Lifting Sling	100	
Lights		
Inspection Lights	53, 116	
LED Lights	116	
Work Lights	116, 120	
Liners, Guide		39
Lisle® Honing Stone Sets	89	
Litmus Paper	67	
Low-Lint Wipes	65	
Lubricants		
Blood Friction Master®	71	
Brake Lubes	121	
Cam-Shield® Assembly Lube	71	
Extreme Pressure Lube	71	
First Lube	71	
Flywheel Grinder Table Lubricant	73, 110	

Lubricants (cont.)	
Press Fit Lube	12, 71, 94
Spray Assembly Lube	71
Universal Gel Lube	46, 70
Way Oil	73

M

Machine Covers	25, 41, 124	
Magnetic Bolt Washer Removers	47	
Magnetic Crack Detection	52 - 53	
Magnetic Strap Silencer	119	
Magnetic Valve Spring Shim Removers	47	
Mallory (Heavy Metal)	111	
Mandrels		
Butterfly Mandrels	59	
Chamfering Cone Mandrels	46, 89	
Cross Buff / Flap Wheel Mandrel	59	
Diamond Sizing System	32	
Honing	86, 92	
Lifter Bore Honing Mandrel	99	
Quick Change	58	
Roll Mandrels	59	
Valve Guide Hone	34	
Manual Ring Grinders		97
Manual Spring Compressors	43 - 45	
Manual Vacuum Testers	54	
Manual Valve Guide Drivers	35	
Markers	61, 70	
Maxxon Work Lights	53, 116	
Measuring Liquid Concentrate	47	

Measuring Tools

Bore Gauges	125, 126	
Calipers	126, 127	
Crankshaft Dial Indicator	104, 127	
Dial Indicators	104, 127	
Distributor Depth Gauge	124	
Feeler Gauges	123	
Flywheel Depth Gauge	110	
Micrometers	128	
Rod Bolt Stretch Gauges	96, 123	
Small Hole Gauge Set	39, 123	
Straight Edges	123	
Stroke Checker	106	
Telescoping Gauge Set	123	
Torque Angle Indicator	57	
Valve Seat Height Gauge	24, 126	
Valve Seat Run-Out Gauge	13	
Valve Stem Concentricity Gauge	25	
Valve Stem Height Gauges	46	
Warp Alignment Gauge	123	
Metal Markers		70
Micrometers		128
Micro Ball Head Tooling		7
Micro Valve Seat Stones		20
Milwaukee-Eight™ Parts		132 - 135
Minnesota Fast Freeze		12, 17, 40
Mitutoyo® Split Ball Bore Gauge		39, 123
Mondello Seat Cutter Blades		8

Motors

Brake Lathe	120	
Crankshaft Polisher	107	
Seat Grinding	19, 21, 23	
Mounted Points		1, 58, 60
Mr. Race Oil Engine Assembly Gel		71

N

Neway

Easy Turn Wrench	14	
Pilots	3 - 5	
Replacement Cutter Blades & Screws	14	
Valve Seat Cutters	14	
Nicasil Honing Stones		89
Number Stamps		106

O

O-Ring Wire	85
OHC Bucket Grinder	45
Oil Filter Tools	98
Oil Gallery Brushes	64, 98
Oil Gallery Cleaning System	66
Oil Gallery Tools	98
Oil Gallery Wax	98
Oil Pump Belts	90
Oil Pump Tools	98
On-The-Engine Spring Compressor	45, 129
Organizers	61
Oversize Bronze-Liners	37
Oversize Valve Guides	37, 134
Oversize Valve Seat Inserts	16, 133

P

Paint

Last Blast Spray Paint	70	
Markers	70	
Paper Shop Towels		65

Parts Cleaning

Airless Blaster Media	69
Baskets	63, 69
Brushes	32, 34, 38, 64 - 66, 98, 99, 101
Detergent Powders	67
Glass Bead Tools & Supplies	68
Gloves	63, 68, 69, 95
Keeper-Keeper	69
Parts Tumbler Solution	69
Pro-Jet Spray Cleaning Powder	67
Roloc Bristle Discs	65
Soda Blast Media	68
Super Scraper™	65
Surface Conditioning Discs	59, 65
Tumbler Cleaning Media	69
Ultrasonic Detergents & Filters	66

Parts Storage & Organizers

Valve Stem Protectors	69
Baskets	63
DOHC Cylinder Head Tray	61
Engine Cart	61
Keeper-Keeper	69
Organizer Trays	61

Index

- Parts Storage & Organizers (cont.)**
Parts Tags & Marker 61
Plastic Bags 63
Safety Pins 61
Shrink Wrap 63
- Parts Tumbler Media** 69
- Pastelub™ Hi-Temp Brake Lube** 121
- Peening Tool** 105
- Performance Brake Lathe Tips** 117
- Peterson**
Boring Bar Cutters 84
Core Drills & Reamers 30
Crankshaft Grinding Wheels 102, 103
Cylinder Head Resurfacing Belts 49
Resurfacers Abrasives 49 - 51
- pH Test Strips** 67
- Pilots**
Expanding 4
Extended Length Top Solid-Tapered 4
Micro 3, 5
Seat Dresser 5, 24
Solid-Tapered Steel 3
Specialty 5, 36, 46
Tapered Carbide 5
- Pin Bushing Press Kit** 94
- Piston Installing Tools**
Deadblow Hammer 96
Electric Rod Heater 95
Gas-Fired Rod Heater 95
Piston Pin Installing Fixture 95, 96
Ring Compressing Pliers 95
Rod Clamping Vise 96
- Piston Pin Removal Fixture** 93
- Piston Ring Filers** 97
- Plastigage** 106
- Plateau Hones** 36, 88, 92
- Plugs**
Crack Repair 55
Oil Gallery 98
Smog Plugs 62
- Pneumatic Tools**
Air Hammer 35
Lapping Tool 17
Valve Guide Drivers 35
Valve Spring Compressors 42, 43
- Polishing Belts** 1, 108, 109
- Polishing Rouge** 107
- Portable Cylinder Hones** 86
- Porting & Polishing**
Aluminum Oxide Cloth Shop Rolls 59
Butterfly Mandrels 59
Crocus Cloth 59
Cross-Buffs® 58, 59
Epoxy 58
Flapwheels 58, 59
Mandrels 58, 59
Mounted Points 58, 60
Port Reshaping Kit 58
Porting Abrasives Kits 1, 58
Porting & Polishing Machining Aid 59
Replacement Abrasives and Mandrels 59
Rotary Files 60
- Powered Ring Filer** 97
- Premium Tapered Reamers** 62, 116
- Press Fit Lubricant** 12, 71, 94
- Press Kit, Tapered Pin** 94
- Pressure Lube** 71
- Pressure Tester Rust Inhibitor** 56
- Pro Jet Spray Cleaning Powder** 67
- Prussian Blue** 13
- Pullers** 16, 40, 57, 111
- Pumps** 33, 72
- ## Q
- QualCast Products** 37, 40
- ## R
- Radiac Abrasives**
Blanchard Grinder Wheels 51
Cam Grinding Wheels 101
CBN Cutters 48
CBN Flywheel Grinding Wheels 113
Crankshaft Grinding Wheels 102, 103
Flywheel Grinding Wheels 113
PCD Cutters 48
Resurfacing Segments 50
Resurfacing Wheels 51
Rod & Cap Grinding Wheel 91
Valve Refacing Wheels 26 - 27
- Radial Wire Brushes** 65
- Reamers**
Bronze 31
Carbide Valve Guide 31
Core 30
Diesel 30
High Speed Steel for Cast Iron 31
Piloted Core Reamers 30
Small Diameter 31
Tapered 62, 116
- Reaming Oil** 31, 37
- Rebuilding Kits**
Stone Holder 22
- Reductor Ring Installation Tool** 105
- Removers**
Booster Shim 47
Bronze Liners 39
Cam Bearings 100
Dowel Pin Pullers 111
Keeper 44, 129
Liner Removal Tool Driver 39
Oil Gallery Plugs 98
Piston Pin 93
Piston Rings 95, 96
Stud 57
Tapered Pin Bushings 94
Valve Guide 35
Valve Seat 7, 16
Valve Seat Stone 19 - 24
Valve Stem Seal 40
Washer 47
- Resurfacing Belts** 49
- Resurfacing Coolant** 49, 50, 74
- Resurfacing Dressers** 51
- Resurfacing Spray** 48
- Resurfacing Wheel Segments** 50
- Resurfacing Wheels** 51
- Right Angle Air Driver** 23
- Rimac Spring Testers** 1, 41
- Ring Band Compressors** 95
- Ring Expanders** 96
- Ring Grinders** 97
- Rocker Arm Tools** 57
- Rod and Cap Grinding Wheels** 91
- Rod Balancing Supplies** 97
- Rod Bolt Boots** 96
- Rod Bolt Installing Block** 96
- Rod Bolt Stretch Gauge** 96, 123
- Rod Clamping Vise** 96
- Rod Heaters** 95
- Rod Hone Filter Mat** 73
- Rod Honing** 90, 91
- Rod Honing Oil** 74, 88, 90, 99
- Roloc Bristle Discs** 65
- Rotary Broach Tool Bits** 48, 110
- Rotary Files** 60
- Rotor Adaptors** 121
- Rotor Silencers** 119
- Rottler**
Boring Bar Cutters 84, 85
Sleeve Cutters 84
Valve Refacer Wheels 26
- Round Brake Lathe Tips** 117
- RTI Brake Lathe Tips** 117
- Rubber Abrasive Belt Dresser** 107
- Rust Protection** 56, 72, 73
- ## S
- Saber Tooth Seat Cutter Blades** 8 - 11
- Safety Glasses** 59, 60, 111
- Safety Pins** 61
- Scales, Balancing** 97
- Scrapers** 65, 100
- Screws**
Ball Head 6, 7
Boring Bar 84
Carbide Cutter 6, 7, 14, 15
Catspaw 84
Cross Buff Mandrel 59
Feed Screws 118 - 122
Neway 14
- Scribe Tool** 13
- Seal-All™** 56
- Seals** 30, 40, 133
- Seal Cutters** 36, 129
- Seal Pullers** 40
- Seal Setters** 133
- Seats** 16, 133
- Seat Cutters** 8 - 12, 14 - 15, 46
- Seat Cutting Fluid** 14
- Seat Drivers** 17
- Seat Grinding** (see Valve Seat Grinding)
- Seat Removers** 7, 16
- Segments** 50
- Serdi-Style Bodies & Drivers** 6

Index

- Shim Remover** 47
Shim Stock 62
Shims 47, 62
Shot
Ceramic & Steel 69
Glass 68
Shop Towels, Low Lint 65
Shrink Wrap 63
Silencer Bands, Brake Lathe 119
Sioux™ Replacement Parts
Belts 28
Driver Parts 19, 21, 22, 28
Parts Tumbler Rebuild Parts 69
Vacuum Tester Gauge 54
Valve Grinder Parts 28
Valve Refacer Parts 28, 29
Wheel Dresser Parts 24
Sioux-Style
Drive Adaptor 21
Drivers 21
Pilots 3 - 5
Stone Holders 22
Vacuum Plates 54
Valve Refacer Wheels 27
Valve Seat Grinding Kit 21, 23
Valve Seat Stone Removers 21, 24
Valve Seat Wheels 20, 21, 23
Sizing Balls 38, 39
Sling, Lifting 100
Sludge Filter Bag (Sock) 72
Smog Plugs 62
Snap-on
Replacement Brake Lathe Cutting Tips... 117
Valve Refacer Wheels 27
Spark Plug Thread Chaser/Burnisher 62, 116
Spindle Boots 122
Split Ball Bore Gauge 39, 123
Spot Facers 62
Spray Assembly Lube 71
Spray Bluing Fluid 13
Spring Compressors 42 - 45, 129
Spring Pad Cutters 12, 46
Spring Testers 41
Stamps, Steel 106
Steady Rest Shoes 29, 105
Steel Shim Stock 62
Step Gauge 110
Stone Holders 19 - 23
Stones
Camshaft 101
Crankwheel 102, 103
Flywheel 112, 113
Honing 86 - 92
Porting & Polishing 58, 60
Refacing 26, 27
Resurfacing 50, 51
Rod Honing 90, 91
Valve Seat 18 - 23
Storage Bags 63
Storage Cart 61
Storm-Vulcan
Crankshaft Grinding Wheels 103
Resurfacers Belts 49
Resurfacers Wheel Segments 50
Resurfacing Carbide Cutter Tips 48
Straight Edges 123
Stroke Checker 106
Stroker Mimic™ 105
Stud Extractor 57
Stud Stretchers 50
Sunnen®
Adjustment Pinion 86
AG-Series Precision Gauge 124
Align Hone Stones 92
Belts for Rod Honing Machines 90
Cap Grinding Wheels 91
Coolants & Oils 74
Core Drills & Reamers 30
CV-616 Honing Machine Parts 29, 90
Cylinder Honing Stones 86 - 92
Dial Bore Gauges 125
Guide Shoes 88, 90, 91
Lifter Bore Hones 99
Mandrel Drivers 90, 92
Master Holder & Stone Supports 87
Oil Pump Belts 90
Plateau Honing Tools, Ultra-Finish 88
Portable Cylinder Hones 86
Press-Fit Lubricant 12, 71
Replacement Parts for CV-616 29, 90
Rod Honing Machine Belts 90
Rod Honing Stones & Guide Shoes .. 90, 91
Silicon Compound (AN-30) 92
Truing Sleeves 34, 99
Valve Guide Gauge Set 124
Valve Guide Hone Set 34
Valve Refacer Steady Rest Shoes 29
Valve Refacer Wheels 26, 27
Super Scrapper™ 65
Surfacing
Belts 49
CBN Inserts 48
Coolants 49, 50, 74
PCD Inserts 48
Segments 50
Wheels 51
Swedge Cutting Tool 118
Switches 19, 21, 28, 120
T
Tapered Pin Bushing Kit 94
Tapered Reamers 62, 116
Tapping Fluid 13, 55
Taps
Crack Repair 55
Telescoping Gauge Set 123
Temperature Indicator Crayons 95, 105
Thin Wall Bronze Liners 39
Thread Chaser 62, 116
Timing Chain Tensioner 85
Tip Holders, Brake Lathe 118
Titanium Coated Cutting Tips 117
Tooling Stands 46
Top Cutters 33, 62
Torque-Angle Indicator 57
Trays, Organizing 61
Trizact™ Crank Polishing Belts 1, 108
Tumbling Media 69
U
Ultra-Finish Plateau Honing Tools .. 36, 88, 92
Ultrasonic Detergents & Filters 66
Universal Checking Standards 128
Universal Dressing Stand 24
Universal Gel Lube 46, 70
Universal Head Holder 47, 57
Universal Spring Pad Cutter 12
Utility Rolls 59
UV Inspection Light 53, 116
V
V-Twin
Compression Release Valves 130
Hard Parts 130 - 135
On-the-Engine Spring Compressor ... 45, 129
Valve Guides 134
Valve Seals 133
Valve Seat Inserts 16, 133
Valve Spring Compressors 45, 129
Valve Springs 130 - 132
Valves 132, 135
Vacuum Plates 54, 55
Vacuum Testers 54, 55
Valve Grinding
Adaptor for ½" Chucks 25
Black & Decker Valve Refacer Collets 28
Diamond Dresser Tools 29, 115
Dresser Pilots 5, 24
Machine Covers 25
Machine Parts 28, 29
Valve Grinding Aid 25, 74
Valve Grinding Oil 27, 74
Valve Refacer Wheels 26, 27
Valve Stem Concentricity Gauge 25
Valve Guide
Bronze-Liners 38, 39
Brushes 32, 34, 38, 64
Core Drill / Reamer 30
Diamond Hone Set 32
Drivers 35, 36
Flex-Hones® 34, 83
Gauge Sets 39, 123, 126
Guides 37, 134
Hone Set 32, 34
Knurling Tools 37
OD Chamfer Tool 33
OD Knurling Tool 37
Plateau Hones 36
Reamers 31
Small Hole Gauge Set 39, 123
Spot Facer 62

Valve Guide (cont.)	
Top Collars	33
Top Cutters	33, 62
Valve Guide Brushes	32, 38, 64
Valve Guides	37, 134
Valve Lapping Tools & Supplies	16, 17
Valve Refacing Wheels	26, 27
Valve Seal Drivers	133
Valve Seal Pullers	40
Valve Seal Setter	133
Valve Seals	30, 40, 133
Valve Seat	
Basic Valve Seat Grinding Kits	19, 21
Bounce Springs	6, 7, 21, 24
Cutter Blades	8 - 11, 14, 15
Cutter Drivers	6, 7, 14, 15
Cutting Fluid	14
Cutting System	6, 7, 14, 15
Dressers	19, 21, 24
Drivers	19, 21, 23
Inserts	16, 133
Layout Fluids	13
Machining Aid	13
Minnesota Fast Freeze	12, 17
Neway Seat Cutting System	14
Nickel-Chrome Valve Seats	16
Removers	7, 16
Run-Out Gauges	13
Stone Holders	22, 23
Valve & Seat Scribe	13
Valve Seat Cutter Blades	8 - 11, 14, 15
Valve Seat Counterbore Cutters	15
Valve Seat Grinding	18 - 24
Valve Seat Insert Driver	17
Valve Seat Wheels	18 - 21
Valve Spring	
Adaptors	43, 44
Booster Shims	47
Calibrated Springs	1, 41
Compressors	42 - 45, 129
Height Indicator	40
Inserts	47
Keeper Installation Tools	44, 129
Manual Valve Spring Bench	43
Pneumatic Valve Spring Press	42
Seat Cutters	46
Spring & Retainer Kits	130 - 132
Testers	1, 41
Valve Spring Inserts	47
Valve Spring Shim Remover	47
Valve Spring Testers	1, 41
Valve Stem	
Concentricity Gauge	25
Dial Indicated Valve Stem Height Gauge ...	46
Protectors	69
Valve Stem Oil Seals	30, 40, 133
Valves	132, 135
Van Norman	
Boring Bar Cutters & Parts	84, 85
Core Drills & Reamers	30
Crankshaft Grinding Wheels	103
Flywheel Cutter	110
Resurfacer Segments	50
Single-piece Resurfacer Wheels	51
Valve Refacer Wheels	27
Vials, Level	7, 48
Vizard Porting Kit	1
Vortec Tools	62

W

Warp Gauge	123
Water Based Honing Coolant	74, 85
Way Oil	73
Wear Inserts, Ammco	120
Wear Sleeves	15
Welding Rods	106
Wipes	65
Wire Wheels & Brushes	64, 65
Wrist Pin Bushing Press Kit	94

California Proposition 65



WARNING: Cancer and Reproductive Harm - www.P65Warnings.ca.gov

"Proposition 65 requires businesses to provide warnings to Californians about significant exposures to chemicals that cause cancer, birth defects or other reproductive harm."

Due to recent regulatory changes in California, we must now warn you that many of the materials commonly used to manufacture our products contain chemicals known to the state of California to cause cancer and reproductive harm.

A complete list of materials requiring the Prop 65 warning can be found at <https://www.p65warnings.ca.gov>.

WARNING: Operating, servicing and maintaining a passenger vehicle or off-road vehicle can expose you to chemicals including engine exhaust, carbon monoxide, phthalates, and lead, which are known to the State of California to cause cancer and birth defects or other reproductive harm. To minimize exposure, avoid breathing exhaust, do not idle the engine except as necessary, service your vehicle in a well-ventilated area and wear gloves or wash your hands frequently when servicing your vehicle. For more information go to www.P65Warnings.ca.gov/products/passenger-vehicle.

If you need additional information about any specific products sold by Goodson, please check our website or contact the Goodson Techxperts for details. Call 1-800-533-8010.

Your Shortcuts

Use the space below to record your most frequently ordered items.

Policies

Pricing:

Prices are subject to change without notice. There is no minimum order. Orders are billed at the prices in effect at the time of shipping. Discounts are not available on Sunnen® QualCast or ULTRASONIC, LLC products.

Shipping:

Goodson makes every effort to ship orders the same day they are received. Due to carrier cut-off times, orders received after 2:00 pm (central time), on weekends or holidays may not ship until the next business day.

You have several choices of shipping methods. Cost of shipping is based on total weight or package dimensions and the distance from our warehouse. **Goodson is not responsible for weather related shipping delays.**

- **STANDARD:** Unless otherwise requested, we ship items up to 100 pounds and up to 130" in combined width, length and height by US Postal Service, UPS or FedEx services. Items over the weight or size limit must go by common carrier.
- **EXPRESS:** We can ship most items by air to arrive in your choice of 1, 2 or 3 days. Aerosol products, however, require a HazMat fee when shipped by air.

Upon receipt of your order, please inspect all cartons immediately for damaged or missing products BEFORE signing for the merchandise. Any packages received in a damaged condition should be rejected and/or noted at the time of delivery. If items are missing or damaged, please contact Goodson within 3 business days.

Freight Allowance:

For open account orders shipped ground within the USA, you may deduct the freight charges on any **JOBBER** net invoice of **\$800** or more if you pay within 30 days (including Internet orders). However, Glass Beads, Steel Shot, Tumbler Media, Machines, Equipment, Bulk Liquids, Cleaning Detergents and Crankwheels are not included (shipped F.O.B. Winona, MN). Hazardous Materials, Dangerous Goods and Dimensional Shipping fees may apply on certain items. Please call to inquire.

Open Account Terms:

- 1) A 1% discount is given on merchandise if payment is made within 15 days from invoice date. This discount applies to the merchandise amount, before shipping, taxes & fees on the invoice. The discount amount is shown in the lower left hand corner of the invoice. This discount does not apply to statement payments and does not apply to credit card or PayPal orders.
- 2) Balances not paid in full within 30 days are subject to a finance charge of 1.5% per month (18% per year).

Credit & Debit Card Orders:

Goodson accepts MasterCard, Visa, American Express, Discover Card and PayPal. For your security, credit card numbers are NOT kept on file. Credit card and PayPal orders do not qualify for the 1% quick-pay discount.

Check Acceptance:

In the unlikely event that your check is returned for insufficient or held funds, we will debit your checking account electronically for the face amount of the check plus the service fee allowed by your state's law. This allows us to resolve the problem without turning you over to a collection agency and harming your credit rating. The transaction will appear on your bank statement and no one will have to contact you about payment.

Returns:

You may return any item, **except special orders and HazMat* items**, within 60 days. We will do our best to correct any problems or to send a replacement. If an item was damaged through mis-use or modification, Goodson will not accept it as a return. Credits will only be issued after it is determined that the part is resellable or it is deemed defective.

To return an item, please follow these easy steps:

1. Enclose a note explaining why you're returning the product. For faster processing, be sure to include your name and account number (you'll find this on your invoice)
2. Ship the item freight prepaid within 60 days from invoice date to
Goodson Tools & Supplies for Engine Builders
ATTN: Returns
156 Galewski Drive
Winona, MN 55987

For best results, please ship return merchandise by a trackable shipping method. Keep your shipping receipt as it may be necessary to track the package if it is lost in transit. A 10% restocking fee may apply on returns unless the problem was the fault of Goodson. If so, the restocking fee is waived and shipping costs are reimbursed.

ABRASIVES WARRANTY: Abrasives have a shelf-life, therefore, all abrasives are warranted against manufacturing defects for 1 year from the date of original purchase.

***HAZMAT ITEMS:** Only businesses certified to ship Hazardous Goods can ship such items. To return a HazMat item to Goodson, please call us at **1-800-533-8010** for shipping recommendations.

Privacy Policy:

All information that Goodson collects from its customers through purchases, credit applications or other transactions is kept private and is not disclosed to anyone except as permitted or required by law. Goodson will not sell or trade this information to anyone. Goodson will limit employee access to customers' private information to only those employees who need to know the information to provide products and services to you. Goodson maintains internal safeguards to protect our customer's non-public information. Please visit our website to read our privacy policy at <https://goodson.com/pages/privacy-policy> or scan the code at right to be directed to the page.



International Sales:

All items shipped F.O.B. Winona, MN, USA. To find a distributor near you, visit www.goodson.com.

Goodson currently has distributors in:

- Austria • Australia • Belgium
- Canada • Chile • Colombia
- Costa Rica • Ecuador
- El Salvador • Finland
- France • Germany
- Guatemala • Honduras • Italy • Luxembourg • Mexico • Netherlands
- New Zealand • Norway • Poland • Portugal • Spain • Suriname
- Sweden • Switzerland • United Kingdom • Venezuela



Resharpener & Resetting:

Goodson offers Resetting & Resharpener services for the following:

- Diamond Dressers • CBN & PCD Resurfacing Cutters
 - Valve Seat Cutter Blades • Rotary Broach Tool Bits for Van Norman
- Get more information and pricing by calling **1-800-533-8010**.



Flex-Hones® For Any Type And Size Of Cylinder

- Abrasive globules each have independent suspension • Self-centering • Self-aligning • Self-compensating for wear
- Applications are interchangeable, select bore size • Right Hand rotation only

CYLINDER HEAD REBUILDING
CLEANING, ASSEMBLY & SAFETY
SHORT BLOCK REBUILDING
CRANKSHAFT/FLYWHEEL GRINDING
MISCELLANEOUS TOOLS & SUPPLIES
BRAKE SERVICE TOOLING
MEASURING TOOLS
V-TWIN & METRIC HARD PARTS

240 Grit Silicon-Carbide Valve Guide Flex-Hones®

- Ideal for all materials including cast iron, bronze, phosphor bronze and aluminum

Size mm	OAL	Order No. Incl.
6 Pc. Kit VGF-KIT ▼		
1 ¹ / ₆₄ " 4.5	6"	VGF-4.5MM
1 ³ / ₆₄ " 5.0	8"	VGF-5MM
7 ¹ / ₃₂ " 5.5	8"	VGF-5.5MM
1 ¹ / ₄ " 6.4	8"	VGF-6.4MM x
9 ¹ / ₃₂ " 7.0	8"	VGF-7MM x
5 ¹ / ₁₆ " 8.0	8"	VGF-8MM x
11 ¹ / ₃₂ " 9.0	8"	VGF-9MM x
3 ¹ / ₈ " 10.0	8"	VGF-10MM x
7 ¹ / ₁₆ " 11.0	8"	VGF-11MM x
15 ¹ / ₃₂ " 12.0	8"	VGF-12MM
33 ¹ / ₆₄ " 13.0	8"	VGF-13MM
7 ¹ / ₁₆ " 14.0	8"	VGF-14MM
19 ¹ / ₃₂ " 15.0	8"	VGF-15MM

400 Grit Diamond Valve Guide Flex-Hones®

- Ideal for heat treated steel, high nickel stainless steel, chromes or plated bores, MMX aluminum alloys, ceramics and carbides

Size mm	OAL	Order No.
1 ¹ / ₄ " 6.4	8"	VGFD-6.4MM
9 ¹ / ₃₂ " 7.0	8"	VGFD-7MM
5 ¹ / ₁₆ " 8.0	8"	VGFD-8MM
11 ¹ / ₃₂ " 9.0	8"	VGFD-9MM
3 ¹ / ₈ " 10.0	8"	VGFD-10MM

120 Grit Silicon-Carbide Flex-Hones®

- Ideal for all materials including cast iron, bronze, phosphor bronze and aluminum
- When ordering heavy-duty, order on cylinder size

Size	Standard		Heavy-Duty	
	mm	OAL	OAL	Order No.
2"	50.8	8"		BG-210
2 ¹ / ₄ "	57.2	8"		BG-225
2 ¹ / ₂ "	63.5	8"		BG-250
2 ³ / ₄ "	69.8	8"		BG-275
3"	76.2	8"		BG-300
3 ¹ / ₄ "	82.6	13 ¹ / ₂ "	13 ¹ / ₂ "	BGD-300
3 ¹ / ₂ "	88.9	13 ¹ / ₂ "	13 ¹ / ₂ "	BGD-325
3 ³ / ₄ "	95.3	13 ¹ / ₂ "	13 ¹ / ₂ "	BGD-350
4"	101.6		13 ¹ / ₂ "	BGD-375
4 ¹ / ₈ "	104.8	13 ¹ / ₂ "		BGD-400
4 ¹ / ₄ "	107.9		13 ¹ / ₂ "	BGD-425
4 ³ / ₈ "	111.1	13 ¹ / ₂ "		BGD-450
4 ¹ / ₂ "	114.3		13 ¹ / ₂ "	BGD-550
4 ⁵ / ₈ "	117.5	13 ¹ / ₂ "		BGD-600
5 ¹ / ₂ "	139.7		17 ¹ / ₂ "	BGD-650
6"	152.4		17 ¹ / ₂ "	BGD-650
6 ¹ / ₂ "	165.1		17 ¹ / ₂ "	BGD-650

180 Grit Silicon-Carbide Flex-Hones®

- Ideal for all materials including cast iron, bronze, phosphor bronze and aluminum
- Sizes with extra-long shanks are ideal for cam bearings

Size	Standard		Extra-Long Shank*	
	mm	OAL	OAL	Order No.
5 ¹ / ₁₆ "	15.9	8"		BH-625
3 ¹ / ₄ "	19.1	8"		BH-750
13 ¹ / ₁₆ "	20.6	8"		BH-820
7 ¹ / ₈ "	22.2	8"		BH-875
1"	25.4	8"		BH-1000
1 ¹ / ₈ "	28.6	8"		BH-1125
1 ¹ / ₄ "	31.8	8"		BH-1250
1 ³ / ₈ "	34.9	8"		BH-1375
1 ¹ / ₂ "	38.1	8"		BH-1500
1 ⁵ / ₈ "	41.3	8"		BH-1625
1 ³ / ₄ "	44.5	8"	17 ¹ / ₂ "	CBF-175*
2"	50.8	8"	17 ¹ / ₂ "	CBF-200*
2 ¹ / ₄ "	57.2	8"	17 ¹ / ₂ "	CBF-225*
2 ¹ / ₂ "	63.5	8"	17 ¹ / ₂ "	CBF-250*
2 ³ / ₄ "	69.8	8"	17 ¹ / ₂ "	CBF-275*

*CBF flex-hones include an extender & nipple for OAL of 17¹/₂"

320 Grit Standard Duty Silicon-Carbide Flex-Hones®

- Ideal for all materials

Size mm	OAL	Order No.	
1 ¹ / ₄ "	31.8	8"	BG-125320
2 ¹ / ₄ "	57.2	8"	BG-225320
3"	76.2	8"	BG-300320
3 ¹ / ₄ "	82.6	13 ¹ / ₂ "	BG-325320
3 ¹ / ₂ "	88.9	13 ¹ / ₂ "	BG-350320
3 ³ / ₄ "	95.3	13 ¹ / ₂ "	BG-375320
4 ¹ / ₈ "	104.8	13 ¹ / ₂ "	BG-418320
4 ³ / ₈ "	111.1	13 ¹ / ₂ "	BG-438320
4 ⁵ / ₈ "	117.5	13 ¹ / ₂ "	BG-462320

320 Grit Heavy Duty Silicon-Carbide Flex-Hones®

- Ideal for all materials

Size mm	OAL	Order No.	
4"	101.6	13 ¹ / ₂ "	BGD-400320
4 ¹ / ₄ "	107.9	13 ¹ / ₂ "	BGD-425320
4 ¹ / ₂ "	114.3	13 ¹ / ₂ "	BGD-450320

240 Grit Aluminum-Oxide Flex-Hones®

- Ideal for hard surfaces such as Nicasil and hardened steel

Size mm	OAL	Order No.	
2 ¹ / ₄ "	57.2	8"	BA-225240
2 ³ / ₈ "	60.2	8"	BA-237240
2 ¹ / ₂ "	63.5	8"	BA-250240
2 ⁵ / ₈ "	66.8	8"	BA-262240
2 ³ / ₄ "	69.8	8"	BA-275240
3"	76.2	8"	BA-300240
3 ¹ / ₄ "	82.6	13 ¹ / ₂ "	BA-325240
3 ¹ / ₂ "	88.9	13 ¹ / ₂ "	BA-350240
3 ³ / ₄ "	95.3	13 ¹ / ₂ "	BA-375240
4 ¹ / ₈ "	104.8	13 ¹ / ₂ "	BA-418240
4 ⁵ / ₈ "	117.5	13 ¹ / ₂ "	BA-462240

RIGHT HAND ROTATION ONLY! For best results, always use with an ample flow of honing oil

... another satisfied customer

"Very happy with both products and service."
- Alliance Diesel, Charlotte, NC, Goodson customer since 2014

CYLINDER HEAD REBUILDING

CLEANING, ASSEMBLY & SAFETY

SHORT BLOCK REBUILDING

CRANKSHAFT/ FLYWHEEL GRINDING

MISCELLANEOUS TOOLS & SUPPLIES

BRAKE SERVICE TOOLING

MEASURING TOOLS

V-TWIN & METRIC HARD PARTS



WINONA VAN NORMAN, VAN NORMAN, PETERSON, KANSAS INSTRUMENTS

1-EDGE CUTTER BIT

Fits Model Numbers	Type	Bit Dia.	Order No.
777, 900, 905, 944, 965	General	1/4"	VN-1
777S, 777S4, 944S, CB11, BC22XL, PK447S	General	3/8"	VGS-1
	Hard Sleeves	3/8"	VGS-2
	Sleeve Cutter	3/8"	VGS-3
888, 999	General	1/4"	VN-360

Original Van Norman

Fits Model Numbers	Type	Bit Dia.	Order No.
777S, 944S	Hard Sleeves	3/8"	777-179

HOLDERS FOR 6-EDGE TIPS - Use RT-6B and RT-6BT (each holder includes one tip)

Fits Model Numbers	Length	Height	Order No.
777, 900, 905, 944, 965	1 7/8"	3/4"	VN-135
777S, 777S4, 944S	2"	1 3/16"	VN-122
Bore Range: 2.65" to 4.50"	VN-122 Adjustment Set Screw		LW-1138

Standard Carbide Replacement Cutter Tip	RT-6B
Titanium Coated Carbide Replacement Tip	RT-6BT enlarged

MISCELLANEOUS PARTS	Order No.
Fits 6-Edge Holders Above	VN-130

tech tips from the techxperts™
VN-130 will also fit KWL-116



KWIK-WAY

1-EDGE CUTTER BIT FOR OE HOLDERS

Fits Model Numbers	Type	Bit Dia.	Order No.
F, FT, FL, FN, FR, FS,	Rough	5/16"	KWL-R
FW, FWS, FWSII, FX	Finish	5/16"	KWL-F
Models After 1770	Sleeve Cutter	5/16"	KWL-C

HOLDER FOR 6-EDGE TIPS - Uses RT-6B or RT-6BT Tips (each holder includes one tip)

Fits Model Numbers	Length	Height	Order No.
FL, FN, FR, FS, FT, FW	2 1/16"	5/8"	KWL-116
Standard Carbide Replacement Cutter Tip			RT-6B
Titanium Coated Carbide Replacement Cutter Tip			RT-6BT

PETERSON-BERCO

1-EDGE CUTTER BIT FOR OE HOLDERS

Fits Model Numbers	Length	Bit Dia.	Order No.
ACP-151-A, ACP-151-BL, SCP-151-P	1 3/4"	10mm	PB-151

ROTTLER

1-EDGE CUTTER BIT FOR OE HOLDERS

Fits Model Numbers	Length	Bit Dia.	Order No.
All Bars	1 3/4"	1 1/32"	RL-1
Sleeve Cutter for All Bars	1 3/4"	1 1/32"	RL-1C

HOLDER WITH 3-EDGE TIP - Includes one RL-2T Tip

Fits Model Numbers	Length	Bit Dia.	Order No.
All Bars (holder includes one tip)	1 1/4"	1 1/32"	RL-2H
Replacement Screw for RL-2H			RL-2S
Replacement Cutter Tip			RL-2T

STORM-VULCAN

1-EDGE CUTTER BIT FOR OE HOLDERS

Fits Model Numbers	Length	Bit Dia.	Order No.
NS, BCG, BCT, 220, 260	3/4"	5/16"	S-1



1-Edge Replaceable Type
Tool holder with separate bit. Excellent cutting yet economical. Resharpen the cutter bit many times. When no longer usable, replace only the bit.

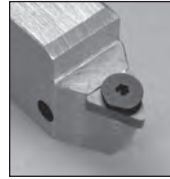

6-Edge Replaceable Type
Lowest-cost choice. Holders take 6-edge, replaceable tips. When one edge wears, turn to new surface. Never need to resharpen - just replace the tip.

Looking for Something Not Listed? Contact Goodson For Special Order Boring Bar Holders or Other Tooling
1-800-533-8010

Cutters enlarged for detail

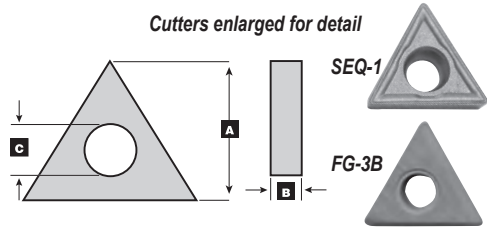

Replacement Tips & Parts

• Fit most boring bar holders

A	B	C	Edges	Order No.
Standard Carbide				
.358"	.097"	.108"	3	SEQ-1
.345"	.094"	.140"	6	RT-6B
.360"	.094"	.124"	3	FG-3B
.327"	.094"	.140"	3	RL-2T
Titanium Coated				
.345"	.094"	.140"	6	RT-6BT

Van Norman, Peterson or Kansas Instruments OE Catspaw Screws For 777S or PK-447S & 944S

Description	Order No.
Catspaw Screws (1 each)	
For #1 Shoe (0.625"L)	800-114
For #2 Shoe (0.740"L)	800-115
For #3, 4 & 5 Shoe (0.940"L)	800-116

Fine Lapping Oil

- A light lap oil coat cools and lubricates
- Use with a variety of applications including diamond laps (below) and crocus cloth (p. 59)

Description	Order No.
Very Fine Lap Oil (4 fl. oz.)	LP-LO-4
Very Fine Lap Oil (8 fl. oz.)	LP-LO-8
Dressing Stick	LP-DS

1 lb. Roll Copper or Stainless Steel O-Ring Wire

- Copper wire is .0403" diameter
- Stainless steel wire is .0410" diameter
- Each roll contains about 200 feet of wire

Description	Order No.
Copper	OWC-0403
Stainless Steel	OWS-041



Boring Bar O-Ring Cutter Replaceable Tool Bits

- Cut grooves for O-rings to enhance gasket sealing for high-performance engines
- Machines a groove .037" wide • 1/4" Shank
- Fit Winona Van Norman, VN, Peterson, KI, Kwik-Way & Rottler Holders (available by special order)

Description	Application	Order No.
Tool Bits	Standard	KWVN-57
	Premium	KWVN-57C6

tech tips

from the techxperts™

To avoid breakage, use the standard cutter on cast iron blocks only and the Premium cutter on hard blocks. **CAUTION:** Avoid column drop as this will break the tips as well.

Conversion Calculator

We've tried to convert as many SAE measurements to Metric (and vice versa) as possible. In some cases there hasn't been enough room.

If you need to convert a measurement, here are the formulas:

Starting Measurement	Conversion Formula	Converted Measurement
Inches (in)	Inches x 25.4	Millimeters (mm)
Feet (ft)	Feet x .3048	Meters (m)
Millimeters (mm)	Millimeters ÷ 25.4	Inches (in)
Fahrenheit (F)	(5 ÷ 9) x (F - 32)	Celsius (C)
Celsius (C)	(9/5 x C) + 32	Fahrenheit (F)

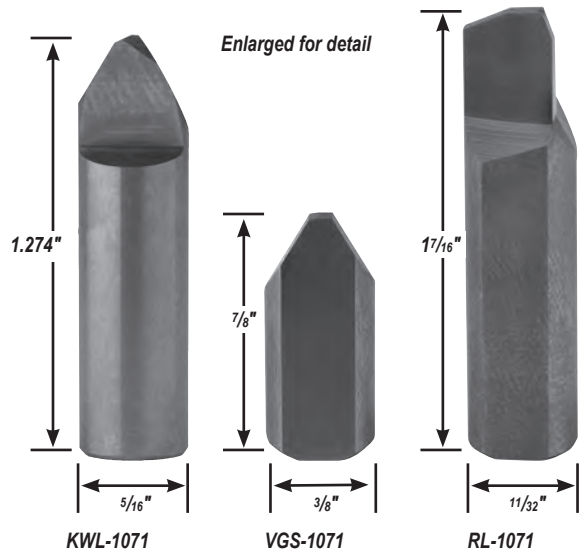

Solid Carbide Formula One Single Pass Boring Tools

- Greater fracture resistance than most carbide bits
- Ideal for hard alloys or interrupted cuts in automotive, high performance, marine, motorcycle and diesel engines

Description	Order No.
Kwik-Way 5/16" x 1.274"L	KWL-1071
Van Norman 3/8" x 7/8"L	VGS-1071
Rottler 11/32" x 17/16"L	RL-1071

Water Based Diamond Honing Coolant

- Suitable for diamond honing on cast iron blocks
- Greatly reduces heat buildup in the block during honing
- Reduces amount of block cleaning after honing
- Disposal of used coolant is easy and more environmentally friendly than conventional honing oils
- 5 gallons makes up to 55 gallons of coolant
- Order No. **DHC-50**



Clear Mineral Based Honing Oil

- Helps keep stones clean and free-cutting
- Ideal for portable hones and all makes of automotive honing machines
- Mixes easily with other brands, including Sunnen®
- **Not** water soluble

Size	Order No.
1 Gal./3.78L	HO-10
5 Gal./18.9L	HO-50



CYLINDER HEAD REBUILDING
CLEANING, ASSEMBLY & SAFETY
SHORT BLOCK REBUILDING
CRANKSHAFT/ FLYWHEEL GRINDING
MISCELLANEOUS TOOLS & SUPPLIES
BRAKE SERVICE TOOLING
MEASURING TOOLS
V-TWIN & METRIC HARD PARTS

tech tips

from the techxperts™

- 1 - Extend the range of your hone with the Master Holder and Stone Supports on the bottom of page 87
- 2 - Use with 1/2" non-pistol grip drill (5/8" drill for AN-815 & GH-2555)
- 3 - Heavy Duty units can also be used in manual hone cabinets

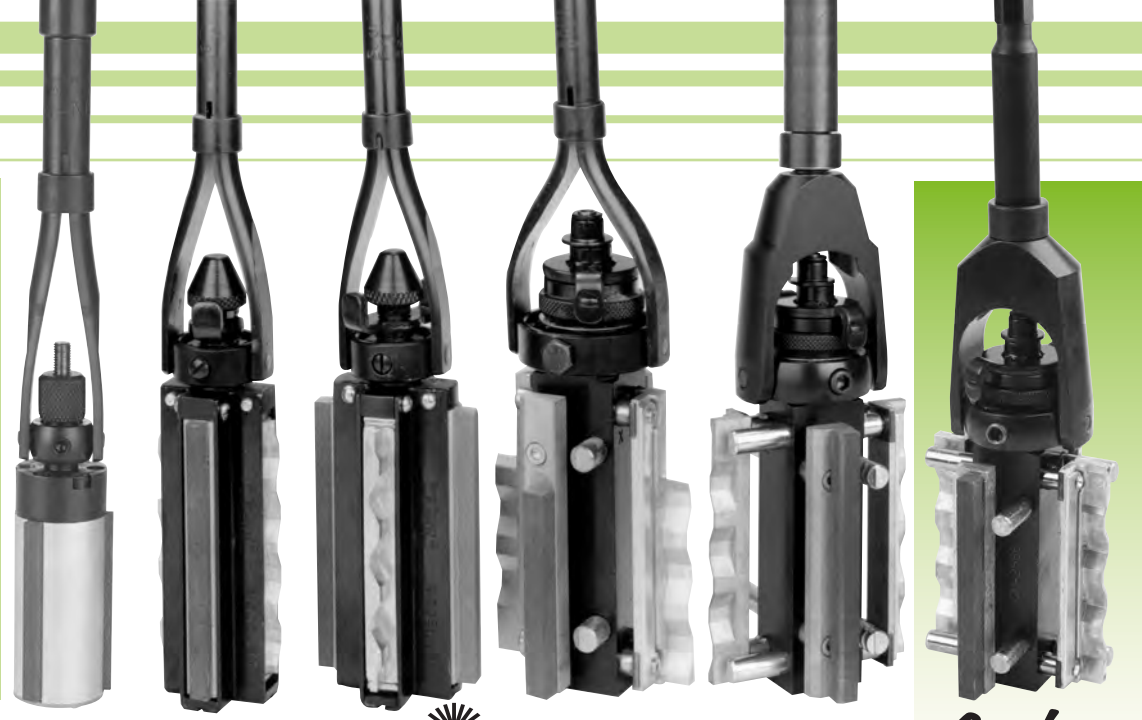

Portable Cylinder Hone Mandrels (stones sold separately)

Shaft extensions available.

	Junior Midget	Midget	Junior	Standard	Heavy-Duty	Heavy-Duty
Brand	Sunnen®	Sunnen®	Sunnen®	Sunnen®	Sunnen®	Goodson
Honing Range	1.25" - 1.75"	1.75" - 2.00"	2.00" - 2.60"	2.50" - 5.50"	2.50" - 5.50"	2.50" - 5.50"
Drive Shank	2.00" (incl.)	2.00" (incl.)	2.00" (incl.)	2.00" (incl.)	6.00" (incl.)	6.00" (incl.)
Drive Extension	12.00" (incl.)	12.00" (incl.)	12.00" (incl.)	12.00" (incl.)	12.00" (incl.)	12.00" (incl.)
Thread	3/8" - 14	3/8" - 14	3/8" - 14	3/8" - 14	3/8" - 11	3/8" - 11
Order No.	SNJ-10	SN-75	JN-95	AN-112	AN-815	GH-2555

NOTE: Goodson is authorized to ship Sunnen® products only within the Americas



Cylinder Hone Center Adjustment Pinion



- Every Sunnen® AN-112, AN-815 and Goodson GH-2555 include the AN-16 Center Adjustment Pinion at purchase
- Use to adjust the stone honing diameter
- The Adjustment Pinion will wear over time so must be replaced
- Order No. **AN-16**



Scan this code with the camera on your smart phone or other smart device for quick access to our Tech Lab Tuesday video showing how important the AN-16 is for cylinder honing success.

Honing Stones

• Ideal for Cast Iron



Grit	Range	mm	Finish	Supersedes	Order No.
For Sunnen® Junior Midget Hone (SNJ-10) 3 Stones & No Wipers					
150 Grit	1.25" - 1.44"	31.8-36.6	45 Ra	-----	SNJ1-J45
	1.42" - 1.60"	36.1-40.6	45 Ra	-----	SNJ2-J45
	1.58" - 1.77"	40.1-44.9	45 Ra	-----	SNJ3-J45
400 Grit	1.25" - 1.44"	31.8-36.6	8 Ra	-----	SNJ1-J87
	1.42" - 1.60"	36.1-40.6	8 Ra	-----	SNJ2-J87
	1.58" - 1.77"	40.1-44.9	8 Ra	-----	SNJ3-J87
For Sunnen® Midget Hone (SN-75) 2 Stones & 2 Wipers					
70 Grit	1.75" - 2.00"	44.5-50.8	120 Ra	SN-100	S18-J17
150 Grit	1.75" - 2.00"	44.5-50.8	45 Ra	SN-200	S18-J45
220 Grit	1.75" - 2.00"	44.5-50.8	32 Ra	SN-300	S18-J55
280 Grit	1.75" - 2.00"	44.5-50.8	20 Ra	SN-500	S18-J65
400 Grit	1.75" - 2.00"	44.5-50.8	8 Ra	-----	S18-J87
For Sunnen® Junior Hone (JN-95) 2 Stones & 2 Wipers					
70 Grit	2.00" - 2.20"	50.8-55.9	120 Ra	JN-100	T20-J17
	2.20" - 2.40"	55.9-60.9	120 Ra	JN-101	U22-J17
	2.40" - 2.60"	60.9-66.0	120 Ra	JN-102	V24-J17
150 Grit	2.00" - 2.20"	50.8-55.9	45 Ra	JN-200	T20-J45
	2.20" - 2.40"	55.9-60.9	45 Ra	JN-201	U22-J45
	2.40" - 2.60"	60.9-66.0	45 Ra	JN-202	V24-J45
220 Grit	2.00" - 2.20"	50.8-55.9	32 Ra	JN-300	T20-J55
	2.20" - 2.40"	55.9-60.9	32 Ra	JN-301	U22-J55
	2.40" - 2.60"	60.9-66.0	20 Ra	JN-502	V24-J65
280 Grit	2.00" - 2.20"	50.8-55.9	20 Ra	JN-500	T20-J65
	2.20" - 2.40"	55.9-60.9	20 Ra	JN-501	U22-J65
	2.40" - 2.60"	60.9-66.0	20 Ra	JN-502	V24-J65
400 Grit	2.00" - 2.20"	50.8-55.9	8 Ra	-----	T20-J87
	2.20" - 2.40"	55.9-60.9	8 Ra	-----	U22-J87
	2.40" - 2.60"	60.9-66.0	8 Ra	-----	V24-J87



Goodson and Sunnen® Cylinder Honing Stones For all popular AN-style Honers and Hone Bodies

- Integral holder type Honing stone sets have 4 pieces: 2 holders with stones and 2 holders with aluminum wipers • Fit Sunnen® AN Standard, AN Heavy-Duty and Goodson **GH-2555** hones • Use with honing oil
- Stones for Short or Blind Holes are 2¹³/₁₆" long; all other stones are 4" long
- **Mix or Match 5 HN stones, Save 10% off jobber**

Grit	Bore Range		Usage	Finish	SUNNEN®		GOODSON	
	in	mm			Old Order No.	New Order No.	Order No.	Order No.
70 Grit Roughing	2.5"-2.7"	63.5-68.6	Cast Iron	120 Ra	AN-115	G25-J17	HN-115S	
	2.7"-4.1"	68.6-104.1	Cast Iron	120 Ra	AN-100	M27-J17	HN-100S	
			Cast Iron	120 Ra			HN-100R ¹	
	3.5"-5.5"	88.9-139.7	Short/Blind	120 Ra	AN-100-71	M27-J17-71	HN-102S	
			Harley / VW	120 Ra	AN-100F	AN-100F	HN-100F	
			Cast Iron	120 Ra	AN-101	N37-J17	HN-101S	
			Cast Iron	120 Ra			HN-101R ¹	
	4.7"-15.0"	119.4-381	Short/Blind	120 Ra	AN-101-71	N37-J17-71	HN-104S	
			Hard Sleeves	55 Ra	AN-131	N37-J11	HN-131S	
			Cast Iron	120 Ra	AN-106	W47-J17	HN-106S	
Hard Sleeves			55 Ra	AN-136	W47-J11	HN-136S		
150 Grit Medium	2.5"-2.7"	63.5-68.6	Cast Iron	45 Ra	AN-215	G25-J45	HN-215S	
	2.7"-4.1"	68.6-104.1	Cast Iron	45 Ra	AN-200	M27-J45	HN-200S	
			Short/Blind	45 Ra	AN-200-71	M27-J45-71	HN-202S	
	3.5"-5.5"	88.9-139.7	Hard Sleeves	30 Ra			HN-230S	
			Cast Iron	45 Ra	AN-201	N37-J45	HN-201S	
			Short/Blind	45 Ra	AN-201-71	N37-J45-71	HN-204S	
	4.7"-15.0"	119.4-381.0	Hard Sleeves	30 Ra	AN-231	N37-J43	HN-231S	
			Cast Iron	45 Ra	AN-206	W47-J45	HN-206S	
			Hard Sleeves	30 Ra	AN-236	W47-J43	HN-236S	
	220 Grit Finishing	2.7"-4.1"	68.6-104.1	Cast Iron	32 Ra	AN-300	M27-J55	HN-300S
3.5"-5.5"		88.9-139.7	Short/Blind	32 Ra	AN-300-71	M27-J55-71	HN-302S	
			Cast Iron	32 Ra	AN-301	N37-J55	HN-301S	
Short/Blind		32 Ra	AN-301-71	N37-J55-71	HN-304S			
Use Master Holder & Sleeve Support	4.7"-15.0"	119.4-381	Cast Iron	32 Ra	AN-306	W47-J55	HN-306S	
280 Grit Fine Finish	2.5"-2.7"	63.5-68.6	Cast Iron	20 Ra	AN-515	G25-J65	HN-515S	
	2.7"-4.1"	68.6-104.1	Cast Iron	20 Ra	AN-500	M27-J65	HN-500S	
			Short/Blind	20 Ra	AN-500-71	M27-J65-71	HN-502S	
	3.5"-5.5"	88.9-139.7	Hard Sleeves	12 Ra	AN-530	M27-J63	HN-530S	
			Cast Iron	20 Ra	AN-501	N37-J65	HN-501S	
			Short/Blind	20 Ra	AN-501-71	N37-J65-71	HN-504S	
	4.7"-15.0"	119.4-381.0	Hard Sleeves	12 Ra			HN-531S	
Cast Iron			20 Ra	AN-536	W47-J63	HN-536S		
400 Grit Extra Fine Finish	2.5"-2.7"	63.5-68.6	Cast Iron	8 Ra		G25-J87	HN-615S	
	2.7"-4.1"	68.6-104.1	Cast Iron	8 Ra		M27-J87	HN-600S	
			Hard Sleeves	5 Ra		M27-J85	HN-630S	
	3.5"-5.5"	88.9-139.7	Cast Iron	8 Ra		N37-J87	HN-601S	
			Hard Sleeves	5 Ra		N37-J85	HN-631S	
	Use Master Holder & Sleeve Support	4.7"-15.0"	119.4-381.0	Cast Iron*	2-3 Ra		G25-C05	
Cork Polishing	2.5"-3.3"	63.5-83.8	Cast Iron*	2-3 Ra				
	3.3"-4.2"	83.8-106.7	Cast Iron*	2-3 Ra		MM33-C05		
	4.0"-5.6"	101.6-142.2	Cast Iron*	2-3 Ra		NN40-C05		

(*Cast Iron – 3 Ra., Hard Sleeves – 2 Ra, Steel– 3 Ra)

¹Ruby Aluminum-Oxide abrasive for longer life in rough cutting use

SUNNEN® Master Holder & Stone Supports

- Holds one 4" stone set
- Stones sold separately
- AN-365 requires use of AN-260
- Larger sizes available upon special order

Master Holder	
Dia. Range	Order No.
4.7"-7.0"	AN-355
6.0"-9.0"	AN-365
Stone Supports for AN-365	
6.0"-9.0"	AN-260

Note: Larger sizes available by special order.

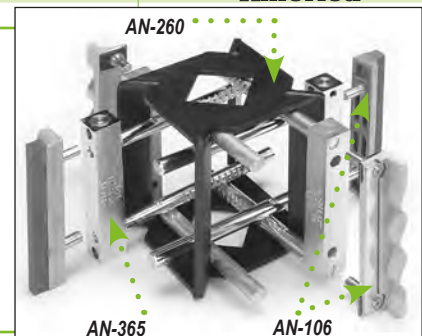

CYLINDER HEAD
REBUILDING
CLEANING,
ASSEMBLY & SAFETY
SHORT BLOCK
REBUILDING
GRANKSHAFT/
FLYWHEEL GRINDING
MISCELLANEOUS
TOOLS & SUPPLIES
BRAKE SERVICE
TOOLING
MEASURING
TOOLS
V-TWIN & METRIC
HARD PARTS

... another satisfied customer

"The thing I like about Goodson is you always have the correct, up-to-date tools."
 — ALC Machine, Santa Rosa, CA, Goodson customer since 1990

CYLINDER HEAD REBUILDING

CLEANING, ASSEMBLY & SAFETY

SHORT BLOCK REBUILDING

CRANKSHAFT/ FLYWHEEL GRINDING

MISCELLANEOUS TOOLS & SUPPLIES

BRAKE SERVICE TOOLING

MEASURING TOOLS

V-TWIN & METRIC HARD PARTS

Keyway Honing Stone Sets

- Two-stroke engines have intake and exhaust ports that interrupt the operation of your honing stone
- These stones allow the hone to pass the intake and exhaust ports while maintaining consistent pressure to remove material accurately and easily
- Use with any AN- or GH-series hone (p. 86)
- For Cast Iron



Grit	Range	mm	Finish	Type	Order No.
150 Grit	2.5" - 3.3"	63.5 - 83.8	45 Ra	Alum.	GY25-J45
Medium	3.3" - 4.2"	83.8 - 106.7	45 Ra	Alum.	MY33-J45
280 Grit	2.5" - 3.3"	63.5 - 83.8	20 Ra	Brass	GY25-J65
Fine Finish	3.3" - 4.2"	83.8 - 106.7	20 Ra	Soft	MY33-J65
400 Grit	2.5" - 3.3"	63.5 - 83.8	8 Ra	Brass	GY25-J85
Extra Fine	3.3" - 4.2"	83.8 - 106.7	8 Ra	Soft	MY33-J85

EHU type stones
GEHN type stones



Stones & Shoes for Sunnen Hone Machines

- Premium-quality replacements for all CV-616, and CK-10 hones equipped with Sunnen® Master Holder Sets
- Diameter Range: 4.125" - 5.000" (104.8 - 127.0mm)
- Use with Master Holder Set CK-3045A (sold separately)
- 2 stones per set

Stones			Goodson - 1 Pair		Sunnen - 6 Pair	
Use	Grit	Finish	Order No.	Order No.	Order No.	Order No.
Hard Blocks	70	60 Ra	GEHN-116	EHN-116		
Hard Blocks	220	22-32 Ra	GEHN-512	EHN-512		
Air Cooled Cyl.	220	22-32 Ra	GEHN-518	EHN-518		
Hard Blocks	70	60 Ra	GEHU-123	EHU-123		
Roughing	70	60 Ra	GEHU-133	EHU-133		
Hard Blocks	220	22-32 Ra	GEHU-518	EHU-518		
Gen. Purp.	220	22-32 Ra	GEHU-525	EHU-525		
Aluminum	220	30-36 Ra	GJHU-525	JHU-525		
High Nickel	280	20-25 Ra	GJHU-623	JHU-623		
Finishing	280	16-23 Ra	GJHU-625	JHU-625		
High Nickel	400	7-14 Ra	GJHU-818	JHU-818		
Aluminum	400	7-14 Ra	GJHU-820	JHU-820		
Accessories			Qty.	Order No.		
Sunnen® Master Holder Set			1	CK-3045A		
Sunnen® Centering Guide (includes CK-3070)			1	CK-3090A		
Sunnen® Guide Shoe & 2 Screws			1	CK-3070		
Sunnen® Brass Guide Shoe & 2 Screws			1	CK-3120		
Goodson Wear Shoe			1	C-3070K		
Goodson Stabilizing Shoe			2	C-3120K		

For Rod Honing Stones and Shoes see page 91

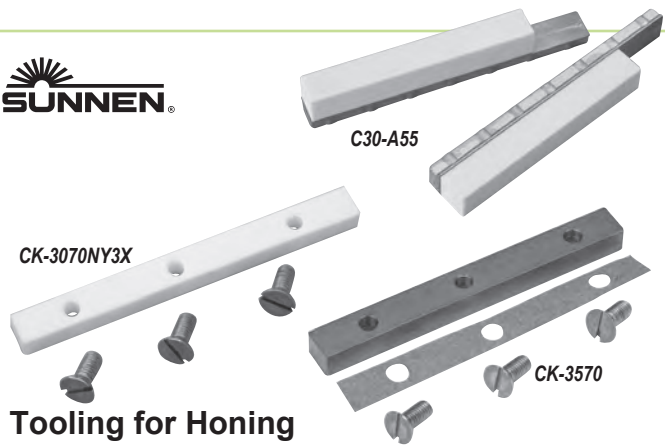

Tooling for Honing Dart Blocks & Ductile Sleeves

- Recommended for Dart™ Machinery
- Use with Sulfurated Rod Honing Oil (below)

Description	Order No.
Honing Stone Sets For Portable Tooling	
80 Grit	N37-A25
220 Grit	N37-A55
280 Grit	N37-J65
400 Grit	MM33-J85
For CK/CV Type Machines	
80 Grit Stone Set (6)	C30-A25
150 Grit Stone Set (6)	C30-A45
220 Grit Stone Set (6)	C30-A55
280 Grit Stone Set (6)	C30-J65
400 Grit Stone Set (6)	C30-J85
Hardened Steel Guide Shoe (1)	CK-3570
Delron® Guide Shoe (1)	CK-3070NY3X
Goodson Brand Shoes For CK/CV Type Machines	
Hardened Steel Guide Shoe (1)	GCK-3570
Delron® Guide Shoe (1)	GCK-3070NY3X

tech tips For CK & CV Machines, **DO NOT** use Bronze Shoes, from the techxperts™ use Hardened Steel and Delron shoes above (1 of each)

Ultra-Finish Plateau Hones



- Abrasive impregnated nylon bristles
- Ideal for rebuilding high-performance engines and engines with low-tension rings • Superior plateau finish so rings will seal immediately
- Reduce break-in time
- Allow closer tolerances • 1 Pair

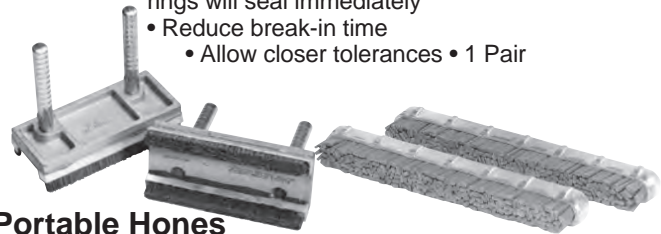

Portable Hones

- Fit AN- or GH- style hones
- Range: 3.78" to 4.68"
- Order No. **MM-PHT-731**

CV/CK Hone Heads

- Range: 3.10" to 5.00"
- Order No. **C30-PHT-731**

Sulfurated Honing Oil

- Includes additives for high pressure cutting

Size	Order No.
1 gal./3.78L	RHO-10
5 gal./18.9L	RHO-50





82° 3" Dia. Chamfering Cones & Mandrel

- Chamfer sharp edges for safe piston and ring installation
- Handles all diameter cylinders or sleeves
- Fits 3/8" (9.53mm) or larger drill
- Kit (CC-100) includes mandrel and three 50 Grit Aluminum Oxide cones (CC-15)
- Due to manufacturing process, abrasive color may vary
- Aluminum-Oxide is a good general purpose abrasive suited for ferrous and non-ferrous metals
- Zirconium is a tough abrasive well suited for heavy stock removal on most metals

Description	Order No.	Incl.
3" Top Dia. Chamfering Cone Kit	CC-100	▼
Replacement 3/8" Drill Adaptor	CC-100-1	x
Aluminum Oxide Chamfering Cones (red)		
40 Grit	CC-14	
50 Grit	CC-15	x
80 Grit	CC-20	
Premium Zirconia Chamfering Cones (blue)		
50 Grit	CCZ-15	
80 Grit	CCZ-20	



Honing Stone Sets For Nicasil

- For deglazing Nicasil with a CV/CK Honing Machine
- Diameter Range:
 - 3.0" - 5.0" (76.2-127.0mm) in standard automotive head
 - 2.6" - 3.5" (66.0-88.9mm) in junior head
- 150 grit aluminum oxide abrasive
- 6 pairs per package
- Order No. EHU-412

Lisle® Honing Stone Sets

- Clip-on style mounts in seconds
- 5" / 127mm stones and wipers
- Each set contains two stones and two felt wipers
- Use dry

Replaces Lisle® No.	Grit	Order No.
15500	80	HL-80
15510	180	HL-180
15520	280	HL-280
15590	500	HL-500

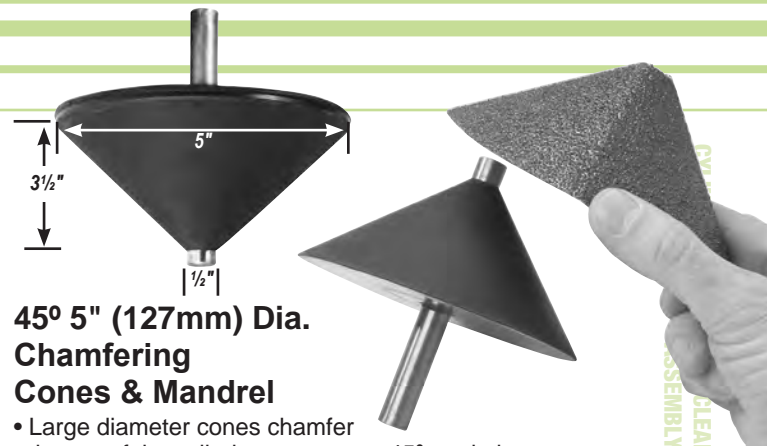

45° 5" (127mm) Dia. Chamfering Cones & Mandrel

- Large diameter cones chamfer the top of the cylinder to an exact 45° angle in one pass
- 1/2" (12.7mm) steel shank is permanently embedded in the cone base to ensure stability
- Cone height: 3 1/2" (88.9mm)
- Kit includes mandrel & one 36-grit cone (CC-30)
- Due to manufacturing processes, abrasive color may vary
- Aluminum-Oxide is a good general purpose abrasive suited for ferrous and non-ferrous metals
- Zirconium is a tough abrasive well suited for heavy stock removal on most metals

Description	Order No.	Incl.
5" Chamfering Cone Kit	CC-130	▼
Chamfering Cones	Abrasive	Grit
	Aluminum Oxide (red)	36
		50
		80
	Premium Zirconia (blue)	36
		50
		80



Honing Stones for Nicasil

- Deglaze Nicasil cylinders with portable hones
- Aluminum-Oxide abrasive
- Resizing cylinders requires diamond abrasive
- A43 = Aluminum-Oxide, J63 = Silicon-Carbide

Stones for SNJ-10 Portable Hones			Stones for AN & GH Style Hones		
Inch	Grit	Order No.	Inch	Grit	Order No.
1.42"-1.60"	150	SNJ2-A43	2.5"-3.3"	150	GG25-A43
	280	SNJ2-J63	3.3"-4.2"	150	MM33-A43
1.58"-1.77"	150	SNJ3-A43	4.0"-5.6"	150	NN40-A43
	280	SNJ3-J63			

Standard Duty 240 Grit Aluminum Oxide Flex-Hones® For Nicasil

Inch	mm	Order No.	Inch	mm	Order No.
2 1/4"	57.2	BA-225240	3 1/4"	82.5	BA-325240
2 3/8"	60.2	BA-237240	3 1/2"	88.9	BA-350240
2 1/2"	63.5	BA-250240	3 3/4"	95.3	BA-375240
2 5/8"	66.5	BA-262240	4 1/8"	104.8	BA-418240
2 3/4"	69.8	BA-275240	4 3/8"	117.5	BA-462240
3"	76.2	BA-300240			

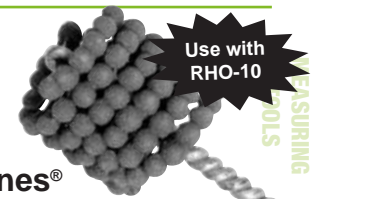

More Flex-Hones® on page 83



"Our tech staff can help you solve problems fast. Call us with questions about product applications, machining processes, longer tool life, improving efficiency and any other technical topic. We're here to help."

- A.J., Goodson Tech Service - 1 year of service

CYLINDER HEAD REBUILDING
CLEANING, ASSEMBLY SAFETY
SHORT BLOCK REBUILDING
CRANKSHAFT/ FLYWHEEL GRINDING
MISCELLANEOUS TOOLS & SUPPLIES
BRAKE SERVICE TOOLING
MEASURING TOOLS
V-TWIN & METRIC HARD PARTS



Stones & Replacement Parts For CR-Series Mandrels

- Sunnen honing stones are sold as pairs while Goodson honing stones are sold individually

Honing Stones for Manual Honing*

Fit Mandrels	Finish	Sunnen Order No.	Goodson Order No.
CR-1450 to 1750	Medium	CR-2	----
	Fine	CR-4	----
CR-1900 & Larger	Aluminum/ Titanium	CR-9	----
	Roughing	CR-10	HC-10
	Medium	CR-12	HC-12
	Fine	CR-14	HC-14
For Power Hone	Roughing	CR-10N	----
Guide Shoes (2 per box)			
CR-1450 to 1750	Die Cast	CR-40D	----
CR-1900 & larger	Die Cast	CR-50D	----
	Bronze	CR-50B	----

Wedge & Wedge Plates

CR-1450 to 1750	Wedge	CR-70	----
	Small Plate	CR-75	----
	Large Plate	CR-85	----
CR-1900 to 2500	Wedge	CR-100	----
CR-1900 & Larger	Small Plate	CR-110	----
	Large Plate	CR-120	----
CR-2900	Wedge	CR-200	----
Sunnen® Tension Block For CR-2900 & Larger			LN-1337A
Sunnen® Shoe Clamps (4 + screws) for CR-1900 & larger			CR-45A

*Sunnen® honing stones include 2/box, Goodson include 1/box

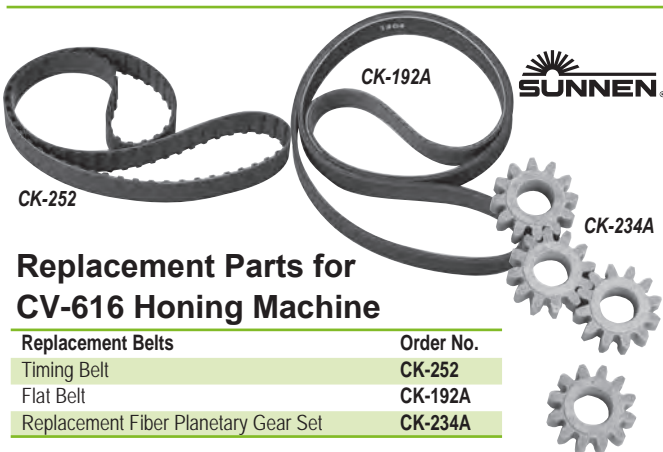

Replacement Parts for CV-616 Honing Machine

Replacement Belts	Order No.
Timing Belt	CK-252
Flat Belt	CK-192A
Replacement Fiber Planetary Gear Set	CK-234A



Mandrel Driver for Portable Use of CR-, PL- and ML-Series Honers

- Ideal for spindle bushings mounted on axles and other jobs that can't be taken to the honing machine
- For holes 3/4"/19.05mm ID and larger, where length is at least 3 times the diameter
- ID Range: .744" - 3.875"/19mm - 98mm
- Graduated adjustment knob advances and retracts stones • 275 - 450 RPM range
- Use with any 1/2"/12.7mm drill or larger
- Order No. **GGN-150**



Rod Honing Oil

- Includes additives for high pressure cutting
- Keeps stones clean and free-cutting during rod reconditioning, pin fitting and other honing applications
- Will mix with other honing oils (including Sunnen®)



Size	Order No.
1 gal./3.78L	RHO-10
5 gal./18.9L	RHO-50



Goodson Belts for Sunnen® Rod Honing Machines

- Top-quality belts for long life

tech tips

from the techexperts™
You must measure the belt you are replacing. Ordering is based on length, not machine model. If your belt size doesn't match one in the chart, order the next size down. For example, if your belt measures 72 1/2", order the 70" Oil Pump Belt. Belts stretch over time so the shorter belt will fit.



Size	Order No.
Oil Pump Belts (.250" dia.)	
70"/1.78m	RHB-70
74"/1.88m	RHB-74
85"/2.16m	RHB-85
109"/2.77m	RHB-109
Flat Belts	
46 1/2" x 5/8"/1181.1x15.9mm	RHFB-46

Rod Honing Stones & Mandrels



KL-Series Connecting Rod Lifetime Honing Unit Mandrel Adaptor

- Mandrel Adaptor comes with retainer
- Order No. AK20-A



Rod Honing Stones, Guide Shoes & Replacement Parts

- Premium-quality • Choose Goodson or Sunnen®

SL
Stones



HP / PL
Stones

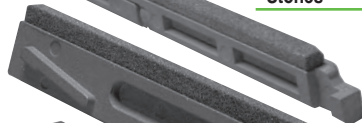

HM / ML
Stones



HK / KL
Stones

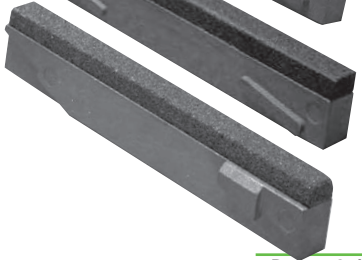

Bronze
Guide
Shoes

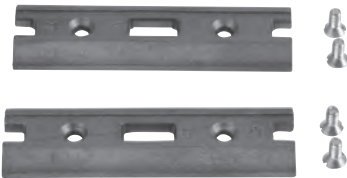

Stones	Use	Goodson Order No.	Qty.	Sunnen® Order No.	Old Order No.	Qty.
For Sunnen® SL720 - SL2300 Mandrel						
	Roughing			SL-5		6
	General Purpose	WorldwideShipping		SL-7		6
	Finishing			SL-13		6
For Sunnen® PL Series Mandrel						
	Roughing	HP-5	1	P28-J27	PL-5	12
	General Purpose	HP-7	1	P28-J47	PL-7	12
	Finishing	HP-13	1	P28-J67	PL-13	12
For Sunnen® ML Series Mandrel						
	Roughing	HM-5	1	P20-J25	ML-5	12
	General Purpose	HM-7	1	P20-J47	ML-7	12
	Finishing	HM-13	1	P20-J67	ML-13	12
For Sunnen® KL Series Mandrel						
	Roughing	HK-5	1	K20-J25	KL-5	12
	General Purpose	HK-7	1	K20-J47	KL-7	12
	Finishing	HK-13	1	K20-J67	KL-13	12
	Steel			K20-A69	KL-14	12
Bronze Guide Shoes		Order No.	Qty.	Order No.		Qty.
For Sunnen® KL and ML Series Mandrel						
	.775"-.805"	19.7-20.4mm	---	UA-B		2
	.838"-.899"	21.3-22.8mm	---	UB-B		2
	.900"-.993"	22.9-25.2mm	---	UC-B		2
	.994"-1.125"	25.2-28.6mm	---	UD-B		2
	1.119"-1.250"	28.4-31.8mm	---	UE-B		2
Note: Bronze guide shoes outlast die cast 6 to 1.						
Zinc Alloy Guide Shoes		Jobber	Order No.	Qty.	Order No.	Qty.
For Sunnen® PL and ML Series Mandrel						
	1.355" - 1.500"	34.4-38.1mm	---	WC-D		2
	1.480" - 1.625"	37.6- 41.3mm	---	WD-D		2
	1.730" - 2.000"	43.9- 50.8mm	---	WE-D		2



When cutting action of your honing stone slows down, a light stroke with the diamond dresser breaks the glaze and restores honing efficiency. Especially recommended for rod reconditioning. Consists of diamond stone on a sturdy metal holder with a chain for fastening it to the honing machine.



Diamond Stone Dresser

- Diamond stone on durable metal tool
- Order No. MAN-700

tech tips
from the techxperts™

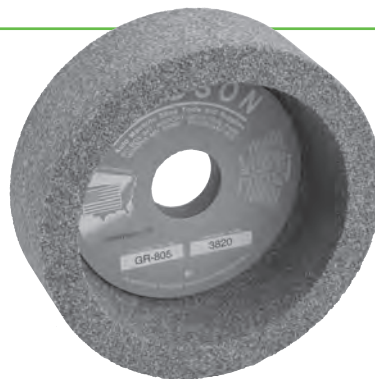

Rod & Cap Grinding Wheels

- Fits Sunnen® Rod and Cap Grinding Machines
- Recessed design
- Size: 6" x 2" x 1 1/4" (152.4 x 50.8 x 31.8mm)
- Order No. GR-805



Rod & Cap Grinding Wheels

- For Sunnen® and other popular brand cap grinders
- Fits CRG 700, 750, 770, 780, 805 & 920K
- Softer than GR-805 • 6" x 2" x 1 1/4"
- Order No. F343793

CYLINDER HEAD REBUILDING
CLEANING, ASSEMBLY & SAFETY
SHORT BLOCK REBUILDING
CRANKSHAFT/ FLYWHEEL GRINDING
MISCELLANEOUS TOOLS & SUPPLIES
BRAKE SERVICE TOOLING
MEASURING TOOLS
V-TWIN & METRIC HARD PARTS

full service
...fast



"If you need engine building tools and supplies, you need Goodson! We're dedicated to providing you with the best quality products, the best value and the best service in the industry."

- Lea, Goodson Customer Service - 1 year of service

CYLINDER HEAD
REBUILDING

CLEANING,
ASSEMBLY & SAFETY

SHORT BLOCK
REBUILDING

CRANKSHAFT/
FLYWHEEL GRINDING

MISCELLANEOUS
TOOLS & SUPPLIES

BRAKE SERVICE
TOOLING

MEASURING
TOOLS

V-TWIN & METRIC
HARD PARTS

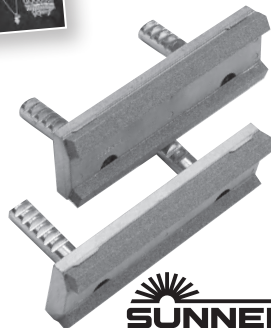

Hone High-Silicon Aluminum Alloy Blocks With Ease – Honing Stones & Silicon Compound

- Stones fit both the Sunnen® AN-112 and AN-815 and the Goodson GH-2555 Portable Honing Mandrels
- Use each stone set progressively until the final bore size is achieved • For Hone Diameter: 3.3" to 4.2"
- To create the final condition, coat the felt set and the honed cylinder surface with the Silicon Compound (AN-30) and lap the cylinders
- After completion, the cylinder will have a dull matte finish
- Piston and rings will ride on silicon instead of aluminum
- Silicon Compound 1 lb. / 450g

Description	Order No.
Roughing (280 grit)	MM33-J63
Finishing (400 grit)	MM33-J85
Polishing (600 grit)	MM33-C05
Felt Set	MM33-FO5
Silicon Compound	AN-30



Mandrel Driver for Line Honing Machines

- For Sunnen® CH-100 & similar line honing machines
- Graduated adjustment knob advances and retracts honing stones
- Quick release lever allows hone removal and installation without resetting
- Stone pressure adjusts with dial
- Automatically advances stones during honing
- **NOT** for portable honing applications
- Order No. CH-75A



Mineral Based Honing Oil

- Formulated for general purpose automotive machine shop honing
- Compatible with most popular honing machines
- 5 gallons (18. L)
- Order No. MAN-845

tech tips

Right Hand Rotation Only.

For best results, keep your RPM about the same as your hone RPM, use the same rate of speed from the techxperts™ and number of strokes per minute.

Ultra-Finish Plateau Soft Hones

- Remove microscopic peaks and scuffs without enlarging bores
- Use with a portable drill
- Abrasive impregnated nylon bristles
- Ideal for high-performance engine rebuilding and for engines that use low-tension rings
- Use **after** honing
- Gives a superior plateau finish so rings seal immediately, reducing break-in time
- Allows closer tolerances for improved compression, better oil control, lower emissions
- For best results, use liberal amounts of honing oil (**HO-50**, pg. 85) • **NOT** interchangeable with Flex-Hones®

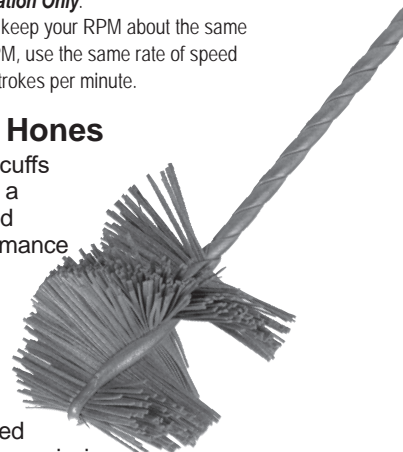

Hole Diameter Range in	mm	Hone Dia.	Head Length	Overall Length	Order No.
.875"-1.00"	22-25	1.250"	2.00"	10.00"	UF-100
1.00"-1.25"	25-32	1.500"	2.00"	10.00"	UF-125
1.25"-1.75"	32-45	2.000"	2.00"	10.00"	UF-175
1.75"-2.25"	45-57	2.500"	2.00"	10.00"	UF-200
2.25"-2.75"	57-70	3.000"	3.00"	10.00"	UF-250
2.50"-3.00"	63-76	3.500"	4.00"	14.00"	UF-300
3.00"-3.50"	76-89	4.000"	4.00"	14.00"	UF-350
3.50"-4.00"	89-102	4.500"	4.00"	14.00"	UF-400
4.00"-4.50"	102-114	5.000"	5.00"	14.00"	UF-450
4.50"-5.00"	114-127	5.500"	5.00"	14.00"	UF-500

Valve Guide Plateau Hones on page 36



Line Hone Stones & Shoes

- For the Sunnen® CH-100, CHV-31, CH-20 & CH-40 Line Honing Machines
- Stones for Aluminum blocks (RY24-J45) are softer than those for cast iron (RY24-J49)

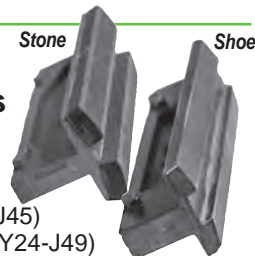

Description	Order No.
Replacement Stones — 5 per box (Requires 10 stones)	
Recommended Application	
Cast Iron	RY24-J49
Aluminum	RY24-J45
Replacement Shoes — 10 per box (Requires 20 shoes)	
Fit 10RY-2400G & 10RY2700G	RG-D
Fit 10RY-3000H	RH-D

Goodson is
Authorized to Ship
Sunnen Automotive
Products into Canada

Rod & Piston Work

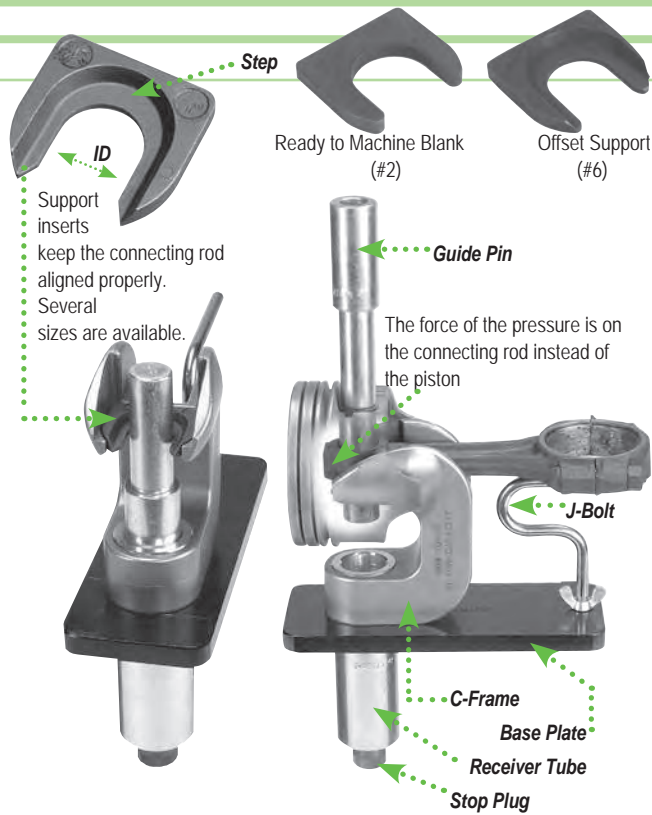

Piston Pin Removal Fixture

- Use to remove or install interference fit piston pins
- Force of removal is against the piston pin and connecting rod – no pressure is exerted on the piston itself
- Tool to fit most popular engines with pin diameters of 0.859" through 1.087"
- Replacement Support Inserts & Guide Pins sold separately

tech tips
from the techxperts™

For Small Block Chevy use Support Insert #1 or Offset #6, for Big Block Chevy, use Support Insert #5, Support #2 is a .275" thick blank, ready to be machined to your exact specifications.

Description	ID	Step	Order No.	Incl.
Complete Kit			PPE-7082	▼
Replacement C-Frame			PPE-302186	x
Replacement Support Inserts	#1	0.945" .100"	PPE-39889	x
	#2	1.110" —	PPE-39890	x
	#3	1.000" .182"	PPE-39888	x
	#4	1.110" .182"	PPE-39886	x
	#5	1.000" .100"	PPE-39887	x
	#6	0.945" .100"	PPE-39822	x
Replacement Guide Pins	0.859"		PPE-17940	x
	0.897"		PPE-17936	x
	0.926"		PPE-17937	x
	0.970"		PPE-17938	x
	0.992"		PPE-17939	x
	1.032"		PPE-17941	x
	1.055"		PPE-17942	x
	1.087"		PPE-18729	x
Replacement Parts				
J" Bolt (Rear Support)			PPE-302224	x
Wing Nut			PPE-10588	x
1 1/2" / 30.2mm Stop Plug			PPE-17830D	x
Base Plate			PPE-17929	x
Receiving Tube			PPE-17931B	x
Body Guide			PPE-17932B	x
5 1/2" / 139.7mm Spring			PPE-17934	x
Guide Pin Driver			PPE-17935	x
1 1/2" / 41.3mm External Spiral Lock			PPE-17945	x

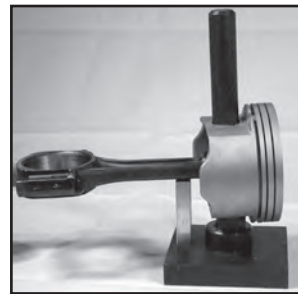

Universal Piston Pin Press-Out Tool

- Use with a shop press
- Top quality steel tooling
- Standard set handles most applications
- You can modify for individual needs

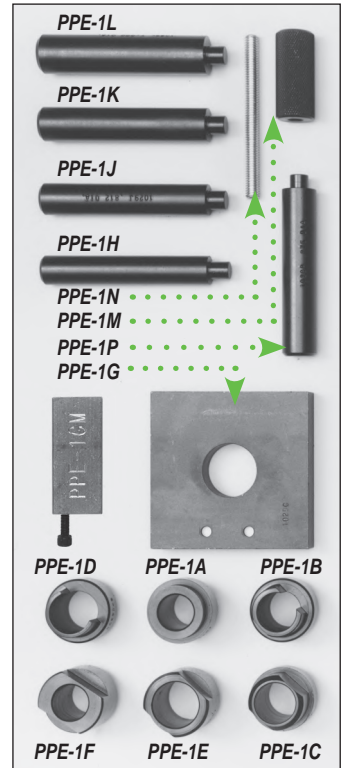

Description	Order No.	Incl.
Piston Pin Extractor Kit	PPE-1	▼
Piston Support Fixtures		
.800" hole	PPE-1A	x
.865" hole	PPE-1F	x
.950" hole	PPE-1B	x
1.010" hole	PPE-1C	x
1.010" hole	PPE-1D	x
1.110" hole	PPE-1E	x
Fixture Base Block (4" x 4" x 3/4")	PPE-1G	x
Pin Pressing Drifts		
.760" dia.	PPE-1H	x
.812" dia.	PPE-1J	x
.875" dia.	PPE-1K	x
1.000" dia.	PPE-1L	x
Tapped Handle	PPE-1M	x
Threaded Rod	PPE-1N	x
Threaded Adaptor	PPE-1P	x
Rod Support	PPE-1GM	x

Kit includes the rod support for tapered boss pistons

GOODSON Rod Support for Sunnen® Pin Press Tooling

- Remove late model connecting rods from tapered boss pistons
- Aluminum construction prevents connecting rod damage • Fits B-162 Pin Press Reducing Ring

Description	Order No.
Rod Support	BRS-130
Pin Press Reducing Ring	B-162

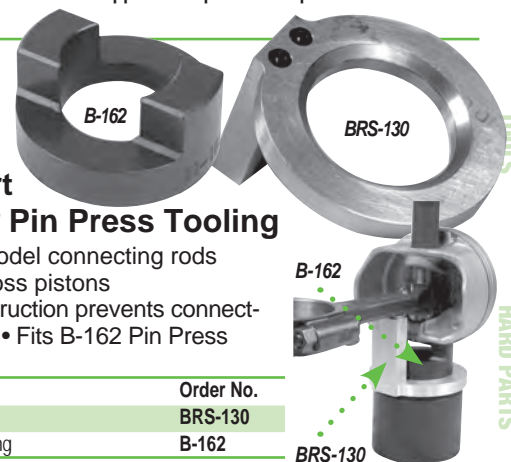

CYLINDER HEAD REBUILDING
CLEANING, ASSEMBLY & SAFETY
SHORT BLOCK REBUILDING
CRANKSHAFT/ FLYWHEEL GRINDING
MISCELLANEOUS TOOLS & SUPPLIES
BRAKE SERVICE TOOLING
MEASURING TOOLS
V-TWIN & METRIC HARD PARTS

... another satisfied customer

"Quality tools, fast turn around time and friendly, helpful people."
 - Norman, NC Machine, Rutledge, Mo, Goodson customer since 2017

CYLINDER HEAD REBUILDING

CLEANING, ASSEMBLY & SAFETY

SHORT BLOCK REBUILDING

CRANKSHAFT/ FLYWHEEL GRINDING

MISCELLANEOUS TOOLS & SUPPLIES

BRAKE SERVICE TOOLING

MEASURING TOOLS

V-TWIN & METRIC HARD PARTS



tech tips
from the techxperts™

Standard Wrist Pin Bushing Driver sizes range from 25mm to 54mm. If we don't have the size you're looking for in the chart below, choose the next size up and turn it down on your lathe to the exact size you require.

Universal Tapered Pin Bushing Press Kit For Light & Medium Duty Diesel Engines

sized for diesel

This press kit is specially designed to remove and replace tapered bushings in most common light to medium duty diesel applications. Don't spend time making a fixture that's dedicated to a single size. Our Tapered Pin Bushing Press Kit is ready to go when you receive it.

Description	Order No.	Includes
Complete Wrist Pin Bushing Press Kit	TB-KIT	▼
Wrist Pin Press Base (select drivers below)	TB-BASE	▼ x
Press Tube - Small (27x21x120mm)	TPT-SM	x
Press Tube - Large (30x31x110mm)	TPT-LG	x
Wrist Pin Ring (50x5x20/26mm)	WPR-001	x
Wrist Pin Parallels (2) 8x10x50mm	WPP-2	x
Extended Mandrel (8 1/2" long)	TB-MANDREL	x

Wrist Pin Bushing Drivers sold by dimension, not application

MM	Nominal	Actual	Step		
25	1.000"	0.957"	0.063"	TBD-25	x
26	1.063"	0.990"	0.058"	TBD-26	x
27	1.060"	1.032"	0.067"	TBD-27	x
28	1.100"	1.006"	0.055"	TBD-28	x
30	1.180"	1.102"	0.075"	TBD-30	x
31	1.220"	1.158"	0.090"	TBD-31	x
31	1.220"	1.198"	0.067"	TBD-31A	x
32	1.260"	1.222"	0.078"	TBD-32	x
33	1.300"	1.268"	0.068"	TBD-33	x
34	1.340"	1.304"	0.073"	TBD-34	x
36	1.420"	1.377"	0.075"	TBD-36	x
38	1.500"	1.458"	0.076"	TBD-38	x
40	1.570"	1.554"	0.068"	TBD-40	x
42	1.650"	1.614"	0.097"	TBD-42	x
45	1.770"	1.742"	0.089"	TBD-45	x
46	1.810"	1.772"	0.108"	TBD-46	x
50	1.970"	1.940"	0.083"	TBD-50	x
52	2.050"	2.012"	0.114"	TBD-52	x
54	2.130"	2.099"	0.081"	TBD-54	x
Goodson Press Fit Lube (6 oz. Aerosol can)				PFL-200*	
Deburring Tool				DT-6	

*Hazardous Goods Fees Apply When Shipped Air

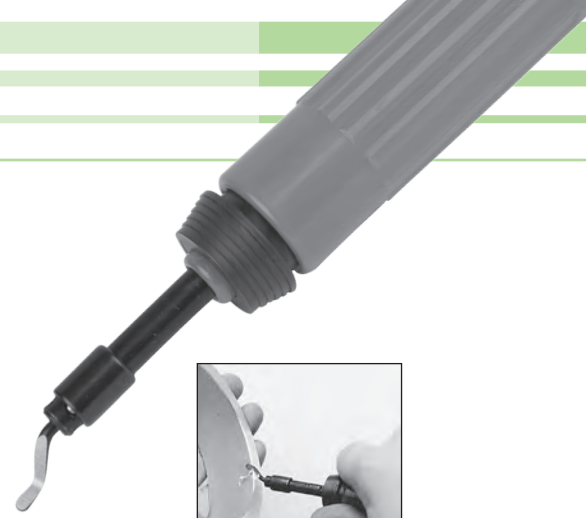

Deburring Tool

- Swivel tool chamfers sharp, machined edges, bolt holes, and much more
- DT-6 includes cutters for aluminum and cast iron

Description	Order No.
Deburring Tool	DT-6
Replacement Cutters	
Steel/Aluminum	DT-10
Cast Iron/Brass	DT-20

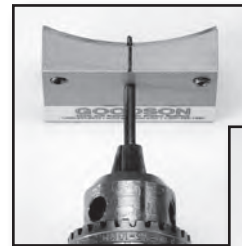

Gas Porting Tools for High Performance

- Virtually eliminate side ring clearance by drilling gas ports in your piston ring lands
- These tiny ports apply compression pressure directly to the back of the ring, pushing it against the cylinder wall with greater force while minimizing compression leakage
- Gas ports work best with piston-compression heights of 1.2" or less on engines running at high rpm (7,000 or higher)
- This simple tool kit take the guess-work out of gas porting and include everything you'll need to get started
- The complete kit includes: Drill Fixture, Depth Bushing and one Drill Bit

US Patent No. US D617,664 S

Description	Order No.
Gas Porting Tool Kits	GPT-043
.040" Drill Bits (5 Pack)	GPT-040-DB
Gas Porting Tool Kits	GPT-062
.0625" Drill Bits (5 Pack)	GPT-062-DB



Rod & Piston Work

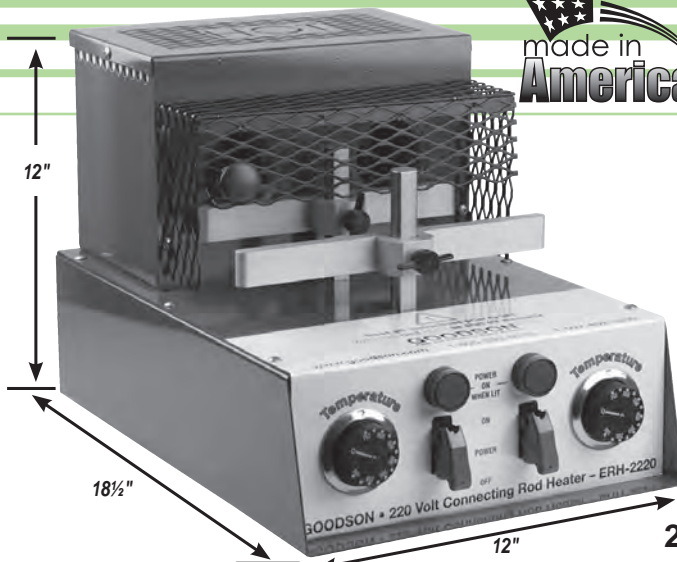

Toggle switches with flip-up covers to prevent accidental activation. LED lamps indicate when power is active.



Heating elements operate on separate thermostats.

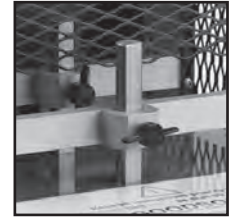

Adjustable rod supports accommodate most automotive connecting rods.

CYLINDER HEAD REBUILDING
CLEANING, ASSEMBLY & SAFETY
SHORT BLOCK REBUILDING
CRANKSHAFT/ FLYWHEEL GRINDING
MISCELLANEOUS TOOLS & SUPPLIES
BRAKE SERVICE TOOLING
MEASURING TOOLS
V-TWIN & METRIC HARD PARTS

220V, Single-Phase Electric Rod Heater

- Includes a digital timer and 450° temperature crayon
- Double wall insulated heat chamber with safety screen
- Vented top for better performance
- Powder-coated heavy-gauge steel housing for long life

Temperature Indicating Crayon

- Mark the workpiece before heating
- Melts when temperature is reached

Melting Point	Order
450°F / 232.22°C	TIC-450
500°F / 260.00°C	TIC-500
600°F / 315.56°C	TIC-600

Gauntlet Style Heat & Flame Resistant Gloves

- Heavy lined red terry-cloth • 13½" Long
- Safe to 450°F / 232.2°C
- Order No. HFR-300

Description	Order No.	Incl.
220V, 50/60 Hz Single Phase Electric Rod Heater	ERH-2220	▼
Digital Read-Out Timer (battery included)	ERH-TIMER	x
Replacement Toggle Switch (ea.)	ERH-SWITCH	
Replacement Toggle Switch Guard (ea.)	ERH-TSG	
Replacement Thermostat (ea.)	ERH-THERM	
Replacement Heater Coil (ea.)	ERH-COIL	
Replacement LED Light Assembly (ea.)	ERH-LED	
Replacement Bezel Knob (ea.)	ERH-KNOB	
Replacement Thumbscrew (ea.)	ERH-TST	
450° Melting Point Temperature Indicator Crayon	TIC-450	x
Piston Pin Installation Fixture	PIF-25	



Assemble 8 rods & pistons in as little as 5 minutes

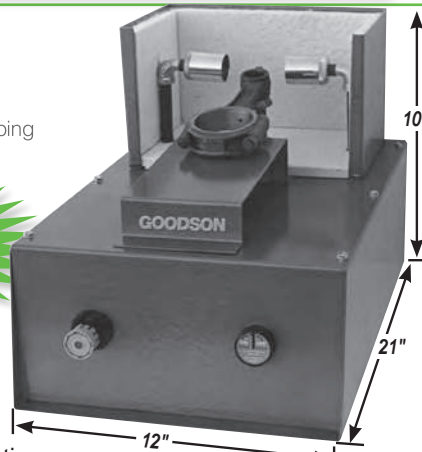

Propane Fired Rod Heater

- Needs no warm-up time – start assembling rods and pistons almost immediately
- Heats piston pin ends so fast the rest of the rod stays cool
- Minimal cool down time after assembly
- Ceramic lined enclosure contains flame to keep hands safe
- One knob controls the pilot and gas flow, another sets air flow for ideal combustion
- Burner lights easily with a striker (not included)
- No heat coils to burn out or circuitry to fail
- Includes one 600°F Temperature Crayon (above)
- Propane model includes gas regulator and hose assembly
- **Made to order - contact Goodson for current pricing and delivery time**

Description	Order No.
Rod Heater for Propane	RH-50
Rod Heater for Natural Gas	RH-50N

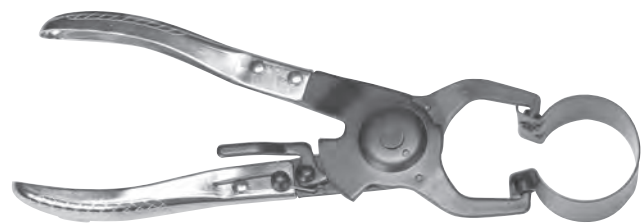

Band Ring Compressor Kits

- Install rings safely and easily • Hardened steel for durability
- Trigger ratchet mechanism for tight compressions

Description	Order No.	Incl.
6 Pc. Band Ring Compressor Kit	GPS-98	▼
9 Pc. Band Ring Compressor Kit	GPS-99	▼
Compressing Pliers	GPS-98A	x x
Bands Range in. mm		
1.875" - 2.125"	47.63-53.98	GPS-98Q
2.125" - 2.375"	53.98-60.33	GPS-98R
2.375" - 2.625"	60.33-66.68	GPS-98S
2.625" - 2.875"	66.68-73.03	GPS-98T
2.875" - 3.125"	73.03-79.38	GPS-98B
3.125" - 3.375"	79.38-85.73	GPS-98C
3.375" - 3.625"	85.73-92.08	GPS-98D
3.625" - 3.875"	92.08-98.43	GPS-98E
3.875" - 4.125"	98.43-104.78	GPS-98F
4.125" - 4.375"	104.78-111.13	GPS-98G
4.500" - 4.750"	114.30-120.65	GPS-98H
4.750" - 5.000"	120.65-127.00	GPS-98I
5.000" - 5.250"	127.00-133.35	GPS-98J
5.250" - 5.500"	133.35-139.70	GPS-98N



Rod Clamping Vise

- Align rods and caps perfectly
- Smooth jaws won't damage connecting rods like an ordinary vise
- Clamp rods firmly to align parting faces while torquing rod bolts
- Clamp in a vise or bolt to a workbench
- Order No. **RCV-20**



Watch a how-to video on the product's website listing



Rod Bolt Boots

- Plastic boots protect crank journals & rod bolts during piston installation
- Save crank journals from rod bolt damage
- Don't risk your reputation for quality
- Reusable
- Set of 16
- Order No. **RBP-16**



Rod Bolt Stretch Gauge

- Accurate to .001"
- Features a 1½" dial gauge
- Extra heavy-duty tension spring for repeatable accuracy
- For bolts from 1" to 2½" long
- See more information on rod bolt stretch on page 123

Description	Order No.
Rod Bolt Stretch Gauge	RBSG-3
Optional Contact Point	ERBG-3T
Replacement Pointer	RBSG-P



On the product's website listing



Heavy-Duty Rod Bolt Installing Block

- Mount universal block in a vise to support rod while installing bolts
- Hardened aluminum won't slip
- If the top wears, you can restore it with a file or belt grinder
- Ream holes larger to accommodate oversize bolts
- Order No. **RB-50**



Connecting Rod not included

Piston Pin Installing Fixture

- Adjustable stops prevent over-centering rods
- Adjust the stop once and you're ready to assemble a full set of rods
- Base is pre-drilled to mount to a workbench
- Order No. **PIF-25**

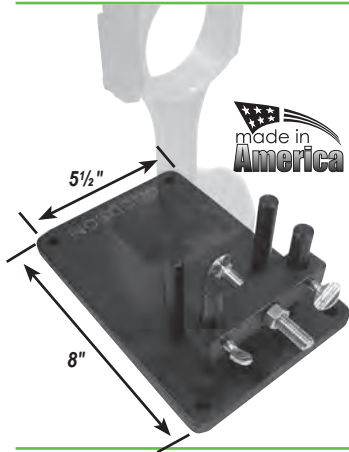

Piston Ring Expander

- Remove and install most rings
- Tapered jaws
- ¾" to ¼" ring width
- Order No. **PRE-500**

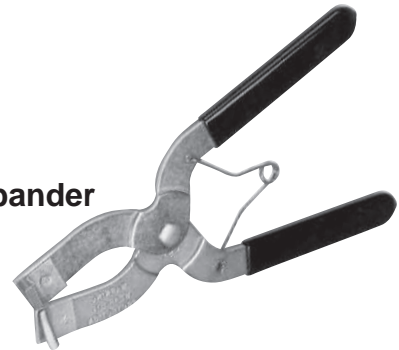

Piston Installing Deadblow Hammer

- 1 piece design
- Specially formulated urethane compound is cut and split resistant
- Convex-faced, non-mushrooming material
- Offset head
- Ideal for fast, mar-free piston installation
- Weighs 1.7 lbs./.77 kg
- Order No. **PK-200**

Fine Abrasive Stick

- Radiused for easier ring deburring after end gapping
- 4" L x ½" radius / 101.6mm x 12.7mm
- Works on all types of rings
- Works on ring ID radii
- Order No. **RS-103**



tech tips

from the techxperts™
Fine Abrasive
Sticks work great for deburring the ends of piston rings after filing, or any part that needs deburring. For a finer finish, soak the abrasive stick in Lapping Oil (LP-LO-4).

made in America

The Original Goodson Powered Ring Filer

- No more tedious filing and checking and filing and checking to get desired end gap; set it once and cut multiple rings
- Easy to read integral dial indicator and positive ring stop make repeatable precision quick and easy
- Fits 2 1/2" to 5" / 63.5 to 127mm diameter rings
- Adjustable guide holds rings square to the cutting wheel
- Table pivots past cutting wheel
- No open ways to gather grinding dust that causes premature wear
- Handy knurled in-feed adjustment knob • High torque motor

Diamond Dresser is securely held in place by the ring clamping pin

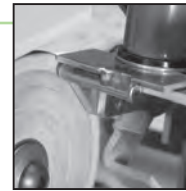

Lighted Rocker Switch

Built-in deburring wheel eliminates the need to hand hone or deburr rings after filing



Also available WITHOUT deburring wheel

Description	Order No.
Powered Ring Filer 110V / 60 cycle w/o Deburring Wheel	PRF-812
Powered Ring Filer with Deburring Wheel 110V / 60 cycle	PRF-812DW
Powered Ring Filer with Deburring Wheel 220V / 50 cycle	PRF-822DW
Replacement Deburring Wheel	PRF-DW
2 1/2" Replacement Grinding Wheel (60 grit) for pre-2008 models	PRF-1001
3" Replacement Grinding Wheel (60 grit)	PRF-1002
Replacement Diamond Dresser	PRF-812D
Replacement Table Spring	PRF-SPRING
Sun-Dura® Canvas Machine Cover	GMC-PRF

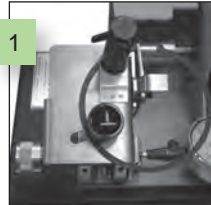

1 Stainless Steel Table

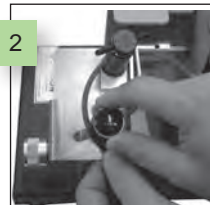

2 Eccentric adjusts quickly and easily

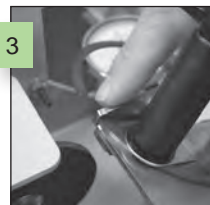

3 Positive ring stop

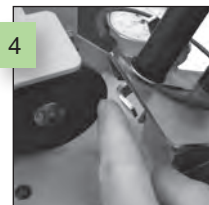

4 Table pivots past grinding wheel



GMC-PRF

Manual Ring Grinder

- Produce end gap rings squarely
- Heavy duty aluminum casting
- Precisely machined for long life
- Aluminum-Oxide wheel holds shape and produces clean precise cuts
- Includes 1 grinding wheel (replacements available)
- Wheel measures 2" OD x 7/16" ID x 1/8" thick

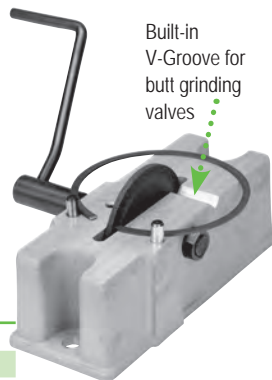

Built-in V-Groove for butt grinding valves

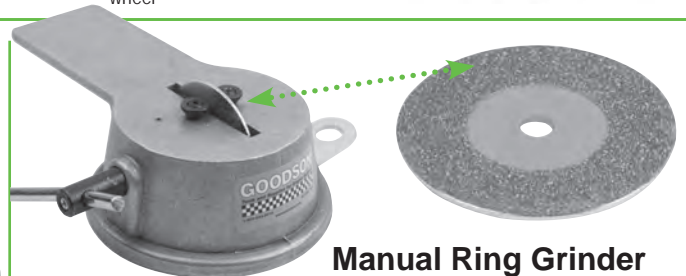

Manual Ring Grinder

- Universal design lets you grind almost any make, type or size of piston ring • Includes diamond abrasive wheel measuring 2" OD x 1/4" ID x 1/16" Thick

Description	Order No.
Piston Ring Grinder	PRF-250
Replacement Wheel	PRF-250W

Description	Order No.
Universal Piston Ring Filer	PRF-500
Replacement Diamond Abrasive Wheel	PRF-870-DW

Rod Balancing Stand

- Ideal for static balancing parts
 - Use to weigh rotating and reciprocating masses and record the information for dynamic balancing
 - Heavy-duty steel construction
 - Includes 1-2" (50.8mm) and 1-2.3" (58.4mm) support discs
 - Height adjustment for different rod sizes
- Order No. BS-201

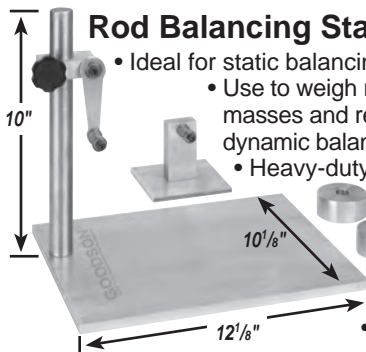

made in America

6100 Gram Balancing Scales

- Scales feature automatic tare weight correction
- 1.0 Gram / 0.100 Ounce increments
- Operates on 9V battery (not included) or 110V converter (included) • Low battery indicator
- Order No. BS-6100



CYLINDER HEAD REBUILDING
CLEANING, ASSEMBLY & SAFETY
SHORT BLOCK REBUILDING
CRANKSHAFT/ FLYWHEEL GRINDING
MISCELLANEOUS TOOLS & SUPPLIES
BRAKE SERVICE TOOLING
MEASURING TOOLS
V-TWIN & METRIC HARD PARTS



"Technology has provided us with more efficient ways to give you, our customers, the quality of service you deserve! Our goal is to make ordering shop supplies faster & easier for you, whether you order by phone or through our website."

- Cheryl, Goodson IT/Order Fulfillment Manager - 29 years of service

CYLINDER HEAD REBUILDING
CLEANING, ASSEMBLY & SAFETY

Oil Gallery Plug Installer / Staker

- Set depth and lock plug in a single step
- Arbor nose aligns cup plug, then follows with two 180° staker lugs to set depth and lock oil gallery plug securely in place
- Order No. **ST-SB**



SHORT BLOCK REBUILDING

Steel Oil Gallery Plugs

- Replace lost or damaged originals
- 1/4" pipe plugs
- For use at the rear of Small Block Chevy oil galleries or other engines with similar size plugs
- 25 per box
- Order No. **OP-250**

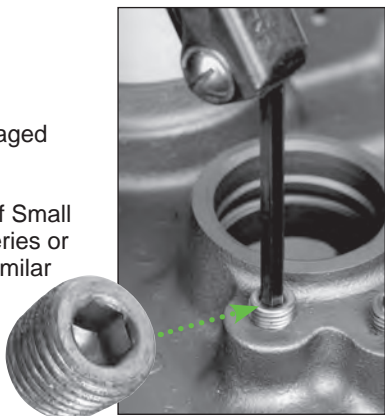

CRANKSHAFT/ FLYWHEEL GRINDING

MISCELLANEOUS TOOLS & SUPPLIES

Oil Gallery Brushes

dimensional shipping				
Steel Wire				
3-pc. Kit	Size	Length	Order No.	Incl.
	1/4" x 3"	24"	OGB-SK	▼
	3/8" x 3"	24"	OGB-1	x
	5/8" x 3"	24"	OGB-2	x
	3/4" x 3"	24"	OGB-3	x
Nylon Bristle				
5-pc. Kit	Size	Length	Order No.	Incl.
	3/8" x 3"	34"	OGB-KIT	▼
	1/2" x 2 1/2"	34"	OGB-38	x
	5/8" x 3"	34"	OGB-42	x
	3/4" x 3"	34"	OGB-5	x
	3/4" x 3"	34"	OGB-7	x
	3/4" x 3"	40"	OGB-8	x

BRAKE SERVICE TOOLING

MEASURING TOOLS



100% Natural Oil Gallery Beeswax

- Preheat the part to be removed, apply wax to its base, allow to cool and remove the part
- 100% natural beeswax
- Measures 1" x 3/4" x 3" • Weighs 1 oz.
- Order No. **BWS-1**

V-TWIN & METRIC HARD PARTS



Includes 1 Replaceable Blade

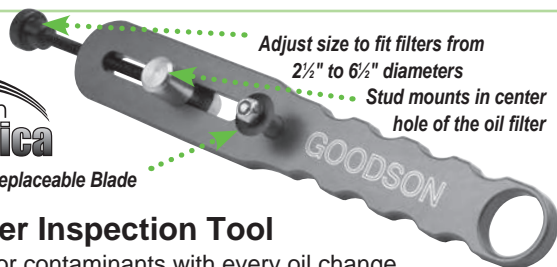

Oil Filter Inspection Tool

- Check for contaminants with every oil change
- Cut open the filter canister for inspection
- Fits 2 1/2" to 6 1/2" diameter filters
- Includes a single blade

Description	Order No.
Oil Filter Inspection Tool	FIT-1-G
Replacement Cutter Blade	FIT-W

Oil Pump Pickup Tube Driver

- For all GM pumps
- Replace pickup tubes easily with a light mallet
- Driver grips the pickup tube flare
- Gives control for fast alignment and installation

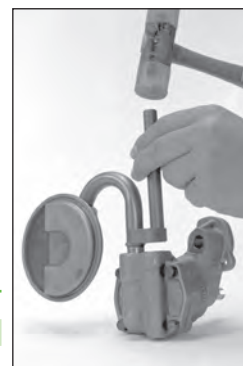

Application	Tube OD	Order No.
Small Block	5/8" / 15.9mm	TI-25
Big Block	3/4" / 19.1mm	TI-30



Oil Gallery Plug Removers

- Power plugs out with an impact wrench
- Threaded plug inside prevents bit from backing into the holder
- Hardened tool-steel holder with lifetime breakage guarantee (excludes bit)
- Tool-steel bit can be reground or replaced
- Set screw holds bit firmly in place
- 1/2" drive – fits your impact wrenches
- Do NOT use with a breaker bar or ratchet



Description	Size	Order No.	Incl.	
Plug Remover Kit	in mm	PPS-KIT	▼	
Replacement Tool	3/16"	4.76	PPS-187	x
Tool includes	1/4"	6.35	PPS-250	x
bit (except PPS-281)	5/32"	7.14	PPS-281*	x
	5/16"	7.94	PPS-312	x
	3/8"	9.53	PPS-375	x
Replacement Bits	3/16"	4.76	PPS-187B	
	1/4"	6.35	PPS-250B	
	5/16"	7.94	PPS-312B	
	3/8"	9.53	PPS-375B	

NOTE: *No bit is needed for PPS-281 (square socket).

... another satisfied customer

"Along with the slide hammer set, the lifter bore burnishing tool fixes tight lifter bores, even on assembled bottom ends quick and easy!! My last race motor build was going great until I noticed a few of my new lifters were real tight at the bottom of the bore.

This tool resized the bores fast and accurate even with the cam still in place. Due to the method of resizing, the entire block isn't contaminated with debris like a hone would do, and saves time and money."

- Grant Farmer, Grand Island, NY, Goodson Customer since 2018

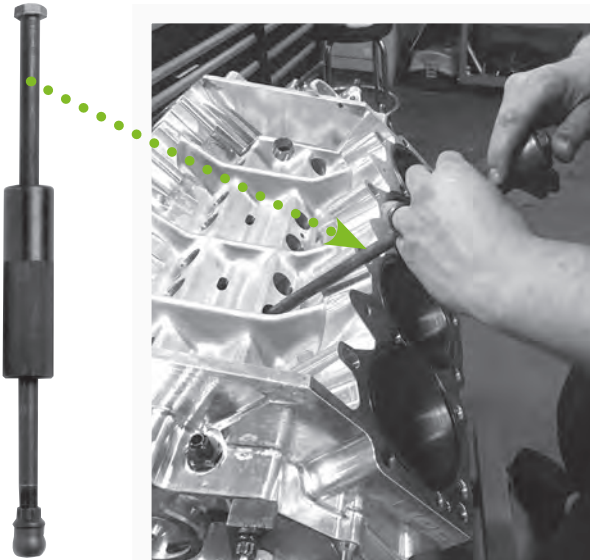

Photo courtesy Tim Wilkerson Racing

Lifter Bore Burnishing Tools

- Eliminate burrs caused by shot blasting
- Drive the burnishing tool into the bore with a soft hammer then slide-hammer it back out
- 60Rc burnishing balls deburr and correct out-of-round lifter bores quickly and easily
- Won't oversize the bore



Lifter Bore Burnishing Balls

Description	Order No.	Includes
Standard Burnishing Tool Set	LBB-1500	▼
14" Slide Shaft	GAO-1	x
15" Slide Shaft	LBB-1	
Slide Hammer	GAO-2	x
Lifter Bore Burnishing Balls		
0.8450" dia. (General Motors)	LBB-GM1	x
0.8760" dia. (Ford)	LBB-FO1	x
0.9060" dia. (Chrysler)	LBB-CR1	x
1.0000" dia.	LBB-1.000	
1.0010" dia.	LBB-1.001	
1.0625" dia.	LBB-1.0625	
1.0635" dia.	LBB-1.0635	
Jam Nut	LBB-NUT	x
Lifter Bore Brushes.		
7/8" (.875") dia.	LBB-875	
1" (1.00") dia.	LBB-100	
1 1/8" (1.125") dia.	LBB-1125	



Sunnen® Lifter Bore Hones

- Restore bore size and finish after shot blasting
- Install oversize lifters for high-performance
- Stones work in cast iron bores or ones sleeved with brass or steel
- Wide stones contact a large area giving better stability for hand honing
- Cross oil ports without catching
- Wedge-type adjustment is a simple, positive way to expand or contract the stone to the precise size needed
- Use a 3/8"(9.5mm) or 1/2"(12.7mm) hand-held electric or air drill at approx. 200 RPM
- Use with honing oil
- **All parts MUST be ordered separately to make a complete unit**

tech tips
from the techxperts™

NOTE: Wedges may come with a tab that must be removed **BEFORE** using them with the P-180 Head

Description	Order No
Honall Head	P-180
Adaptor	PAK20-A
Roughing Stone (280 Grit) 12/box	Y20-J67
Finishing Stone (400 Grit) 12/box	Y20-J87
Standard Lifter Bore Tooling (6" Reach)	
Mandrel .838" - .869" Range	AAAY20838BH6LH
Mandrel .869" - .900" Range	AAAY20869BH6LH
Wedge	Y20-W-6LH
Retainer	LN-3688A-6LH
Truing Sleeve .838" - .869" Range	S-838
Truing Sleeve .869" - .900" Range	S-869
Extended Reach Lifter Bore Tooling (6 1/2" Reach)	
Mandrel .838" - .869" Range	AAAY20838675LH
Mandrel .869" - .900" Range	AAAY20869675LH
Wedge	Y20-W-675LH
Retainer	LN-3688A675LH
Truing Sleeve .838" - .869" Range	S-838
Truing Sleeve .869" - .900" Range	S-869

Goodson is authorized to ship Sunnen products only within the Americas



Rod Honing Oil

- Includes additives for high pressure cutting
- Keeps stones clean and free-cutting during rod reconditioning, pin fitting and other honing applications
- Will mix with other honing oils (including Sunnen®)

Size	Order No.
1 Gal. (3.78L)	RHO-10
5 Gal. (18.9L)	RHO-50

CYLINDER HEAD REBUILDING
CLEANING, ASSEMBLY & SAFETY
SHORT BLOCK REBUILDING
CRANKSHAFT/ FLYWHEEL GRINDING
MISCELLANEOUS TOOLS & SUPPLIES
BRAKE SERVICE TOOLING
MEASURING TOOLS
V-TWIN & METRIC HARD PARTS

... another satisfied customer

"Goodson is such an easy company to do business with. We'll certainly order again."
— David Everitt, Milton, PA, Goodson customer since 2022

CYLINDER HEAD REBUILDING

CLEANING, ASSEMBLY & SAFETY

SHORT BLOCK REBUILDING

CRANKSHAFT/ FLYWHEEL GRINDING

MISCELLANEOUS TOOLS & SUPPLIES

BRAKE SERVICE TOOLING

MEASURING TOOLS

V-TWIN & METRIC HARD PARTS



Threaded Impact Cap now included with all drivers

Universal Cam Bearing Tool

- Remove and install hundreds of sizes of cam bearings with just four mandrels!
- Expanding Mandrels cover a 1.370"-2.250" range
- Adjusts instantly to under-size bearings so you can remove and install them from virtually any block
- Approximately 1/4" range for each size segment
- Interchangeable with Dura-Bond

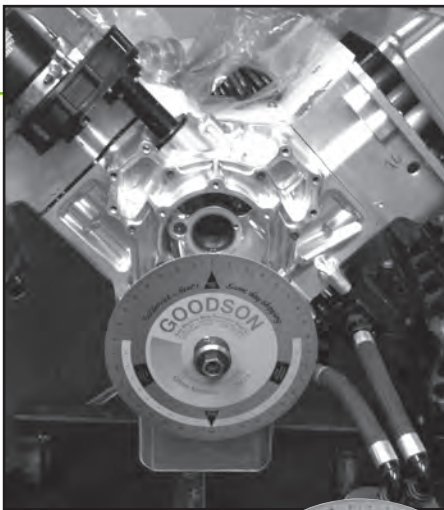

Degree Wheel

- Check cam timing, duration and overlap
- Degree wheel measures 11" / 279.4mm dia. with 1 1/8" / 47.6mm hole • Complete kit includes the Degree Wheel, a 3/4" ID mounting hub for mounting on cranks using 7/16" to 3/4" fasteners, a 1/2" hub and necessary fasteners • Use hubs or turning tool to mount the wheel.
- Use with 1/2" drive ratchet

Wheel / Adaptors	Order No.	Incl.
Automotive Degreasing Kit	DW-KIT-2	▼
Degree Wheel	DW-11	x

This is ... another satisfied customer
one of those customer
MUST have tools for the shop and trailer. We have needed our Goodson Degree wheel at the track a few times and in a few minutes we were done and ready to go! Thanks again for great equipment.
— Dean Dubbin, DMP Awnings (NHRA Top Alcohol Dragster), Goodson customer since 2010

Description	Order No.	Incl.
Universal Cam Bearing Tool	CBT-300	▼
Replacement Segment with Sleeve		
Max Dia. 1.370"	CBT-5M	x
1.682"	CBT-6M	x
1.875"	CBT-7M	x
2.250"	CBT-8M	x
Replacement Backing Plate		
Max Dia. 1.375"	CBT-5W	x
1.682"	CBT-6W	x
1.885"	CBT-7W	x
2.250"	CBT-8W	x
Replacement Neoprene Sleeve		
Max Dia. 1.370"	CBT-5NS	
1.682"	CBT-6NS	
1.875"	CBT-7NS	
2.250"	CBT-8NS	
Drivers		
Length 5" (pictured at left)	CBT-1B	x
24"	CBT-2B	
36" (pictured at left)	CBT-3B	x
48"	CBT-4B	
Miscellaneous Replacement Parts		
1.200" Expander with stud	CBT-3E	x
1 1/8" Expander with stud	CBT-4E	x
1/2"x13 Stud	CBT-1S	
3" Guide Cone	CBT-1C	x
Steel Storage Rack	CBT-300-WR	x
INTERCHANGEABLE WITH DURA-BOND		

Bearing Scraper

- Eliminate bearing high spots after installation to ensure correct oil clearance
- Solid hardwood handle
- 4" / 101.6mm blade with 3 cutting edges
- German steel blade
- Order No. **BS-30**



Lifting Sling

- Lift up to 1800 lbs. safely and easily
- 1" x 36" looped nylon webbing sling
- Do NOT use with caustics or temperatures exceeding 190°F
- Order No. **LS-3**



Whether you're regrinding cores for stock applications or custom grinding for diesel and high performance, you can count on Goodson Cam Grinding Wheels to deliver an excellent finish

Goodson abrasives are second to none. We work with our manufacturers to get you the most ideal grain that's bonded to be free-cutting, yet still shed before loading up. Our Premium wheels are ideal for steel high performance camshafts of 55 to 65 Rc and for Stellite overlays. Goodson finishes all Camshaft Grinding Wheels to your specifications in-house for faster turn-around and delivery. Choose from the sizes below or custom order your cam wheel today!



CYLINDER HEAD
REBUILDING
CLEANING,
ASSEMBLY & SAFETY

Cam Grinding Wheels - WAA54-L5V1 - 54 Grit

Diameter	Width	Arbor	Order No.
18"	3/4"	19mm 6" 152mm	E341420
457mm	7/8"	22mm 6" 152mm	E335351
	1"	25mm 6" 152mm	E335352
	1 1/8"	29mm 6" 152mm	E335353
	1 1/4"	32mm 6" 152mm	E335354



Cam Grinding Wheels - 43A602-K8-V1 - 60 Grit

Diameter	Width	Arbor	Order No.
18"	3/4"	19mm 6" 152mm	E342030
457mm	7/8"	22mm 6" 152mm	E339945
	1"	25mm 6" 152mm	E342031
	1 1/4"	32mm 6" 152mm	E348558



Cam Grinding Wheels - 7BL801 - 80 Grit

Diameter	Width	Arbor	Order No.
18"	3/4"	19mm 6" 152mm	E416880
457mm	7/8"	22mm 6" 152mm	E427392

Due to the manufacturing process, actual colors may vary

Cam Grinding Wheels - WAA100 - 100 Grit

Diameter	Width	Arbor	Order No.
18"	3/4"	19mm 6" 152mm	E379225
457mm	7/8"	22mm 6" 152mm	E397667
	1 1/4"	32mm 6" 152mm	E416183



Standard Goodson Cam Grinding Wheels - 100 Grit

Diameter	Width	Arbor	Order No.
18"	3/4"	19mm 6" 152mm	GCC 18 x 0.750 x 6
457mm	7/8"	22mm 6" 152mm	GCC 18 x 0.875 x 6
	1"	25mm 6" 152mm	GCC 18 x 1.000 x 6
	1 1/4"	32mm 6" 152mm	GCC 18 x 1.250 x 6

Due to the manufacturing process, actual colors may vary

Ask about special order sizes, grits & grains

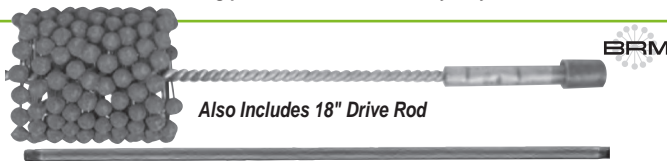

Also Includes 18" Drive Rod

180 Grit Cam Bearing Flex-Hones®

- Silicon-Carbide globules laminated to high density nylon
- Includes 18" drive rod

Inch	mm	OAL	Order No.
1 3/4"	45	17 1/2"	CBF-175
2"	51	17 1/2"	CBF-200
2 1/4"	57	17 1/2"	CBF-225
2 1/2"	64	17 1/2"	CBF-250
2 3/4"	70	17 1/2"	CBF-275

Bore Washing Brushes

- Clean tunnel housing bores and full-annular grooved area
- Heavy, hand-driven shank

Bore Washing Brushes

Dia.	Length	Order No.
2"	36"	CBB-200
2 1/4"	36"	CBB-225
2 1/2"	36"	CBB-250
2 3/4"	18 1/2"	CWB-27W
3 1/2"	18 1/2"	CWB-35
4"	18 1/2"	CWB-40
4 1/2"	18 1/2"	CWB-45
5"	18 1/2"	CWB-50

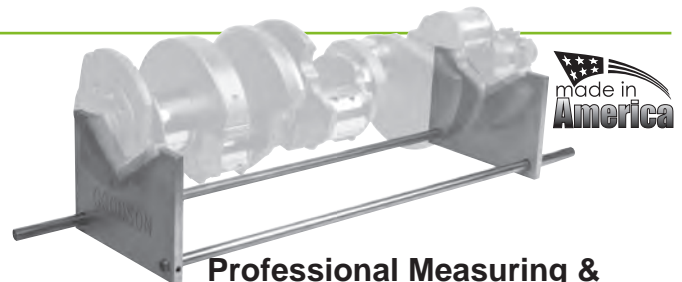

Professional Measuring & Inspection Stand For Cranks & Cams

- Length adjusts up to 23" to fit journal spacing
- Rotate work to view or measure
- Solid aluminum frame with self-lubricating, corrosion and chemical-resistant wear surfaces
- Order No. **PMIS-30**

Cam & Crank Grinding Coolant

- Semi synthetic
- Non-nitrite
- High-lubricity
- Dilute 20 parts water to 1 part coolant



Size	Order No.
1 gallon (3.78L)	CGC-10
5 gallons (18.93L)	CGC-50

SHORT BLOCK
REBUILDING

CRANKSHAFT/
FLYWHEEL GRINDING

MISCELLANEOUS
TOOLS & SUPPLIES

BRAKE SERVICE
TOOLING

MEASURING
TOOLS

V-TWIN & METRIC
HARD PARTS

full service
...fast



"The Mach-B division of Goodson offers many services such as ANSI compliant speed testing, balance testing, grinding wheel shaping, resizing and more. Find out more at Mach-B.com."

- Jon, Goodson Production Manager, 43 years of service

Goodson crankwheels are made-to-order in-house

Other sources stock finished wheels, which makes it virtually impossible to stock a full range of sizes. If they don't have what you need, they may charge more and delay your order for weeks. That's why Goodson makes every wheel to order. We always have the right wheel because we take a Type 1 straight wheel, size it, shape it, speed test it and ship it.

For future reference write down your

Crank Wheel Number (s)

Select the shape



Hub

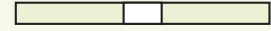

Straight

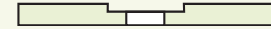

Recessed 1 Side

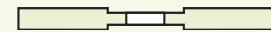

Recessed 2 Sides

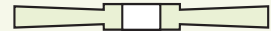

Tapered

Select your wheel grade:

WAA



Superior Grade - 54 grit
Excellent dimensional accuracy, corner radii and surface finish. For multiple applications including weld grinding. Ideal for grinding everything from cast iron to steel. Finishing and roughing wheel.
Aluminum-oxide abrasive for light to medium stock removal.

CSS ULTRA

Premium Grade
This new abrasive formulation combines high-quality components and an innovative bonding technology to produce a long-lived, cool grinding abrasive wheel. White and sintered aluminum-oxide. Increase stock removal rates without sacrificing quality. Limited stock available.

GCH



Superior Grade - 54 grit
Better form holding ability, cuts cooler and needs less dressing. Use on crank journals with Rockwell hardness of 35 Rc or less. Use on crankshafts of cast or forged steel, Nodular iron. Ideal for large radii, thrust and plunge grinding. Great for high-performance.

GCD

Premium Grade - 60 grit
For harder materials. Good form holding ability; cuts cooler and needs less dressing. Grains yield faster, cooler grinding. Use on journals with Rockwell hardness of 35 Rc or more. Ideal for diesel, high-performance, industrial and billet steel.

Increase coolant flow with Crankwheel Slotting

Slotting facilitates the flow of coolant to the thrust and radius areas of the crankshaft to prevent journal burning. Highly recommended for high performance and diesel crankshafts. Don't waste time waiting on other suppliers who outsource their crankwheels for slotting – Goodson has a shop full of equipment, so we slot wheels in house!
Order No. **SLOTING**

How to order:

If you have any questions, please call 1-800-533-8010

Grade	Diameter (OD)	Face Width	Arbor Size (ID)	Machine	Shape
WAA - Superior	Diameters are available from 18" to 36" in most grades.	Most sizes from 3/4" to 2 5/8" (custom widths available). Be sure to include mounting surface thickness.	Arbor size of your grinder. Any arbor hole from 3" to 12".	Identify the make and model of your grinder.	Specify the shape for your grinder. We will need the diameter and depth of tapers, recesses and hubs.
GCD - Premium					
GCH - Superior					
CSS-ULTRA					

Crankshaft Grinding Wheels

Due to the commodity-like nature of abrasive grinding wheels, prices may change without notice. Please call us at **1-800-533-8010** or **1-507-452-1830** to confirm current pricing and availability.

Everyone gets PER Pricing, no additional discounts available!



		WAA	GCH	GCD
Dia.	Face Width			
Fits Storm Vulcan 14, 15				
18"	3/4"-1"			
3" Arbor	1 1/64"-1 1/4"			
	1 17/64"-1 1/2"			
	1 33/64"-1 3/4"			
	1 49/64"-2"			
Fits Storm Vulcan 15, 15 Special, 1550, 1648				
20"	3/4"-1"			
3" Arbor	1 1/64"-1 1/4"			
	1 17/64"-1 1/2"			
	1 33/64"-1 3/4"			
	1 49/64"-2"			
Fits Kwik-Way / Lemppo				
20"	3/4"-1"			
3 3/4" Arbor	1 1/64"-1 1/4"			
	1 17/64"-1 1/2"			
	1 33/64"-1 3/4"			
	1 49/64"-2"			
Fits Kwik-Way / Lemppo 539 & Storm Vulcan 15A (early)				
22"	3/4"-1"			
5" Arbor	1 1/64"-1 1/4"			
	1 17/64"-1 1/2"			
	1 33/64"-1 3/4"			
	1 49/64"-2"			
Fits Peterson Berco 180				
22"	3/4"-1"			
8" Arbor	1 1/64"-1 1/4"			
	1 17/64"-1 1/2"			
	1 33/64"-1 3/4"			
	1 49/64"-2"			
Fits Storm Vulcan 15A (late), 15A Special; RMC/Robbi REX-1200 Fits Kwik-Way / Lemppo KGA and NKG Series				
24"	3/4"-1"			
5" Arbor	1 1/64"-1 1/4"			
	1 17/64"-1 1/2"			
	1 33/64"-1 3/4"			
	1 49/64"-2"			
Van Norman 438, 448, 460, 465; Winona Van Norman/Zanrosso CG-210 (early); Storm Vulcan Scledum 200				
24"	3/4"-1"			
8" Arbor	1 1/64"-1 1/4"			
	1 17/64"-1 1/2"			
	1 33/64"-1 3/4"			
	1 49/64"-2"			
Storm Vulcan 15C				
25"	3/4"-1"			
5" Arbor	1 1/64"-1 1/4"			
	1 17/64"-1 1/2"			
	1 33/64"-1 3/4"			
	1 49/64"-2"			
AMC K1100; Peterson Berco 180, 225; Scledum 200, 230; Van Norman 438, 448, 460, 465, 475, 476; Winona Van Norman CG-210 (late), CG-840				
26"	3/4"-1"			
8" Arbor	1 1/64"-1 1/4"			
	1 17/64"-1 1/2"			
	1 33/64"-1 3/4"			
	1 49/64"-2"			
	2 1/64"-2 1/4"			

		WAA	GCH	GCD
Dia.	Face Width			
Schou 1500/270, 1600, 260				
27 1/2"	3/4"-1"			
8 5/64" Arbor	1 1/64"-1 1/4"			
	1 17/64"-1 1/2"			
	1 33/64"-1 3/4"			
	1 49/64"-2"			
	2 1/64"-2 1/4"			
Peterson Berco 260; SV Scledum 230, 270/280; Zanrosso Mito 250; Van Norman 400, 438, 454, 475, 476, 666; RMC/Robbi REX-1500				
28"	3/4"-1"			
8" Arbor	1 1/64"-1 1/4"			
	1 17/64"-1 1/2"			
	1 33/64"-1 3/4"			
	1 49/64"-2"			
	2 1/64"-2 1/4"			
	2 17/64"-2 5/8"			
Seest MC62				
30"	3/4"-1"			
6" Arbor	1 1/64"-1 1/4"			
	1 33/64"-1 3/4"			
	1 49/64"-2"			
Zanrosso Mito 280; Storm Vulcan Scledum 270/280; RMC / Robbi REX-1800, REX 2200L				
30"	3/4"-1"			
8" Arbor	1 1/64"-1 1/4"			
	1 17/64"-1 1/2"			
	1 33/64"-1 3/4"			
	1 49/64"-2"			
	2 1/64"-2 1/4"			
	2 17/64"-2 5/8"			
AMC 1400, K1500, K1800; Van Norman 467, 477; Zanrosso				
32"	3/4"-1"			
8" Arbor	1 1/64"-1 1/4"			
	1 17/64"-1 1/2"			
	1 33/64"-1 3/4"			
	1 49/64"-2"			
	2 1/64"-2 1/4"			
	2 17/64"-2 5/8"			
Peterson Berco 280, 300; RMC Robbi REX-1800RM; REX-2200, REX-2200RM, REX-2700RM, REX-3100RM				
32"	3/4"-1"			
12" Arbor	1 1/64"-1 1/4"			
	1 17/64"-1 1/2"			
	1 33/64"-1 3/4"			
	1 49/64"-2"			
	2 1/64"-2 1/4"			
	2 17/64"-2 5/8"			
Peterson Berco 300, 350; Storm Vulcan Scledum 250; RMC / Robbi REX-2200M, 2700M, 3100M; Winona Van Norman 111				
36"	3/4"-1"			
12" Arbor	1 1/64"-1 1/4"			
	1 17/64"-1 1/2"			
	1 33/64"-1 3/4"			
	1 49/64"-2"			
	2 1/64"-2 1/4"			
	2 17/64"-2 5/8"			

NOTE: All wheel widths are delivered up to .015" oversized to allow for side dressing when mounting the wheel

CYLINDER HEAD REBUILDING
CLEANING, ASSEMBLY & SAFETY
SHORT BLOCK REBUILDING
CRANKSHAFT/FLYWHEEL GRINDING
MISCELLANEOUS TOOLS & SUPPLIES
BRAKE SERVICE TOOLING
MEASURING TOOLS
V-TWIN & METRIC HARD PARTS

full service
...fast



"We've continually improving our production department to provide more flexibility in grinding wheel shapes and profiles. Give us a call when you need something special."

- Brandon, Goodson Production, 1 year of service

CYLINDER HEAD
REBUILDING

CLEANING,
ASSEMBLY & SAFETY



Crankshaft Journal Radius Gauge

- 16 radii ... 1/32" to 17/64"
- Measure radii of reground journals quickly
- Blades are clearly marked in 1/64" increments
- Use in holder or remove to use blades separately
- Order No. **RG-16**

SHORT BLOCK
REBUILDING

Crankshaft Straightening Peening Tool

- Designed for narrow journals on some new-style V6 crankshafts
- Peen crankshafts in the radius area of damaged journals to straighten
- Long-shank
- Offset-radius face
- 10" long • 0.0625" radius
- 0.125" diameter



tech tips
from the techexperts™
Stay Safe In

The Workplace!
Always wear
protective gear.

Description	Order No.
Peening Tool	CPT-062
Safety Glasses	PGL-21

CRANKSHAFT/
FLYWHEEL GRINDING

Hand-Held Dressing Sticks

- Keep your crankshaft grinding wheels cutting clean

GG-112

DS-NOR



Hard Silicon-Carbide

- 1" x 1" x 6"
- Use to deglaze wheel side
- Removes material with light pressure
- Order No. **GG-112**

Dense Granular Norbide

- 3/16" x 1/2" x 3"
- Long lasting
- For fine tuning radius and side relieving wheels
- Order No. **DS-NOR**

Starrett®

Universal 12"L Quick-Set Crankshaft Grinder Dial Indicator

- 3/8" diameter shaft • 12" long
- .125" travel, .050" per revolution
- Rotating, lockable bezel graduated in .001" from -.025" to + .025"
- Order No. **MDI-12**



Goodson exclusive

More Dial Indicators on page 127

MISCELLANEOUS
TOOLS & SUPPLIES

Mach-B Grinding Wheel Shaping & Resizing



From routine grinding wheel shaping and sizing to emergency work, **Mach-B Can Do That!**

Mach-B Grinding Wheel Shaping & Resizing specializes in:

- Custom Grinding Wheel Shaping
- Custom Grinding Wheel Sizing
- Reducing Outside Diameters
- Increasing Inside Diameters
- ANSI Compliant Speed Testing
- Static Balance Testing
- Standard and Custom Profiles
- Grinding Wheel Slotting



Turn to Mach-B and Goodson for Fast Turnaround. Visit www.mach-b.com for more information.



video
available

Goodson has several videos available related to Camshaft & Crankshaft Grinding. To access them on our website, simply scan the appropriate code with your smart phone or other smart device.

Crankshaft Grinding Wheel Selection



Grinding Wheel Slotting



MEASURING
TOOLS

V-TWIN & METRIC
HARD PARTS



Eliptibur Tool

- Fastest, safest way to chamfer crank oil holes
- Simplify deburring and chamfering of angularly drilled holes on cylindrical surfaces
- Easily produces a chamfer of relative uniformity and depth
- Self-centering, spring loaded pilot
- Includes one replaceable blade
- For 30Rc or softer crankshafts

Description	Order No.
Eliptibur Tool (1 blade included)	EBT-15
Replacement Blade	EBT-15B
Replacement Pilot	EBT-15N

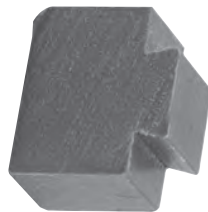

Need Steady Rest Shoes?

Email orderdesk@goodson.com or fax 1-507-452-2907 the design and dimensions for what you need

Crankshaft Grinder Steady Rest Shoes for Peterson-Berco

- Use same shoe for upper and lower replacement
- $\frac{5}{16}$ " thick
- Order No. **RBE-200**



Create a relief in the block for rod #2 at the pan rail area using your normal process.



Place the arbor in main saddles 1 & 2, keeping the flange nearest to the pointer against #2.



Rotate the arbor and adjust the pointer until the tapered end passes freely through the relief with a minimum of clearance.



Lock the pointer in position with the set screw and check the clearance.



Once satisfied, scribe a line on the pointer opposite the set screw.



A Must-Have when building a Stroker Engine!

Stroker Mimic™

- Lightweight and easy to use
- Eliminates the need to repeatedly install and remove the crankshaft, pistons, rod assembly and the necessary bearings when clearancing a block for a stroker crank
- Once the Stroker Mimic™ has been set to a particular crank, rod and piston combination, the tool can be marked or measured for future reference
- Order No. **SM-350**



Reluctor Ring Installation Tool



All steel construction features 2 indexing dowels to properly align the reluctor ring when installing it on the crankshaft. Designed to fit Generation III (LS1, LS6) and Generation IV (LS 2, LS3, LS7) engines. Aligns GM sensor rings (12559353, 12586768). **US Patent No. 7,716,827.**

Goodson exclusive

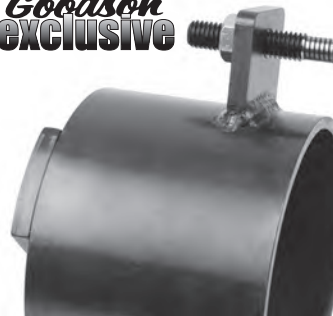

The 8mm indexing dowel is attached to the fixture by an exterior tang. It can be adjusted for depth to accommodate a variety of popular flange widths. This dowel fits into the only 8mm hole on the reluctor wheel.



The internal indexing dowel pin is designed to fit into the dowel pin hole on the crankshaft. It is adjustable to fit different depths. The combination of dowel pins gives very precise alignment of the reluctor wheel and crankshaft.

Description	Order No.
Reluctor Ring Installation Tool	RRJ-350
Temperature Indicating Crayon (450° F/232°C)	TIC-450

tech tips
from the techxperts™

Heat reluctor ring to 450°F (232°C) then slide it onto the casting. Be sure to deburr all components before beginning assembly. Any sharp edges will cause the reluctor ring to catch on the casting, making assembly impossible.

Conversion Calculator

We've tried to convert as many SAE measurements to Metric (and vice versa) as possible. In some cases there hasn't been enough room. If you need to convert a measurement, here are the formulas:

Starting Measurement	Conversion Formula	Converted Measurement
Inches (in)	Inches x 25.4	Millimeters (mm)
Feet (ft)	Feet x .3048	Meters (m)
Millimeters (mm)	Millimeters ÷ 25.4	Inches (in)
Fahrenheit (F)	(5 ÷ 9) x (F - 32)	Celsius (C)
Celsius (C)	(9/5 x C) + 32	Fahrenheit (F)

CYLINDER HEAD REBUILDING
CLEANING, ASSEMBLY & SAFETY
SHORT BLOCK REBUILDING
CRANKSHAFT/FLYWHEEL GRINDING
MISCELLANEOUS TOOLS & SUPPLIES
BRAKE SERVICE TOOLING
MEASURING TOOLS
V-TWIN & METRIC HARD PARTS



"We do our best to get our inventory on the shelves; professionally and correctly packaged and ready for when you need it."

- Brandon, Goodson Receiving, 3 years of service

CYLINDER HEAD
REBUILDING

Plastigage

- Accurately measure bearing clearance
- Color coded by size
- Put a piece on rod or main bearing and torque the cap
- Remove and inspect – width of crushed Plastigage shows clearance
- Use at the workbench or in the vehicle
- 10 per pack

Clearance Range	Order No.
.001" to .003" (.025 to .076mm)	PG-GREEN
.002" to .006" (.051 to .152mm)	PG-RED
.004" to .009" (.102 to .229mm)	PG-BLUE
10pk. Assortment : 5 Green, 3 Red, 2 Blue	PG-10PK



Stroke Checker

- Accurately measure strokes up to 6"
- Works with any precision caliper to accurately measure crankshaft strokes
- Measures strokes up to 6" with an accuracy of .001"
- Rigid, hard-anodized aluminum frame is fully adjustable
- Fits almost any crankshaft
- Order No. **CSG-1**

See page 127 for our selection of calipers



CLEANING,
ASSEMBLY & SAFETY

SHORT BLOCK
REBUILDING

Heavy Duty Steel Stamps

- For hard materials
- Order in sets

Number Sets		Order No.
Figure	Shank	
1/8"	5/16"	SFH-1/8
3/16"	3/8"	SFH-3/16



Special and custom orders are available, call 1-800-533-8010

CRANKSHAFT/
FLYWHEEL GRINDING

Crank Welding Plug Rods

- 3 diameters available
- Each rod is 12½" long and cuts off easily
- Sharpen ends with your existing pencil sharpener
- 5 Crank Welding Plug Rods per pack

Size	Order No.
.250"	CWPR-250
.312"	CWPR-312
.375"	CWPR-375

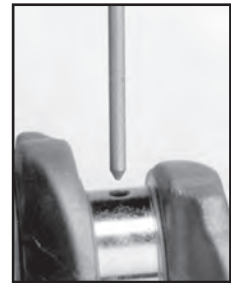

MISCELLANEOUS
TOOLS & SUPPLIES

Sanding, Grinding, Polishing Belts Made to Order In-House

To provide you better service and save you money, Goodson bought an abrasive converting company in 2017. Since then, we've added equipment and personnel and we're cranking out abrasive belts for a wide range of industries. **Abrasive Industrial Supplies** is operated as a division of Goodson and our feet are still firmly placed in the automotive market.

Almost every abrasive belt shown in the Goodson catalog is manufactured by **Abrasive Industrial Supplies (AIS)** but that's just the beginning. We know you use belts on machines other than cylinder head resurfacers and crankshaft polishers and we're ready to meet those supply needs too.

Contact your Customer Service Representative today to get current pricing. Have AIS make something great for you!

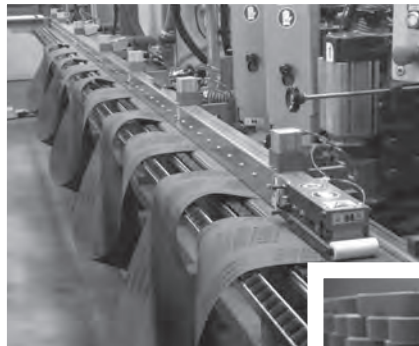

Abrasive Industrial Supplies
A Division of Goodson Manufacturing

MEASURING
TOOLS

BRAKE SERVICE
TOOLING

V-TWIN & METRIC
HARD PARTS

Crankshaft Polishing

Crankshaft Polishing Starter Kit

- Includes 1 each of:
- Grind Aid,
 - Polishing Rouge,
 - Abrasive Dresser and
 - 5-Pack of our most popular 72" belts
 - Order No. **CP-KIT**



Grind Aid

- Cools and lubricates
- Reduces loading-up and grain fracturing
- Belts produce a better finish and last up to twice as long
- Use only on cloth-back belts such as those shown on pages 108 & 109
- Order No. **GRA-10**



Polishing Rouge

- Produces high luster finish
- Use with light pressure, for cork or fine grit polishing to finish crank journals perfectly
- Hard, dry compound becomes viscous with heat
- White • 16 oz. / 454 g
- Order No. **CPR-16**



Natural Rubber Abrasive Belt Dresser

- Prolongs belt life
- Hold at 45° angle on moving belt to remove foreign material
- Restores cutting ability of grains
- 2" x 2" x 4" / 51 x 51 x 102mm
- Order No. **ACB-224**

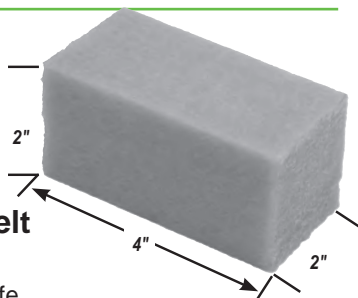

Check out the Crankshaft Polisher in action! Scan the code below with the camera on your smart phone or other smart device to see the **Crankshaft Polishing** episode of **Tech Lab Tuesday**.



dimensional shipping

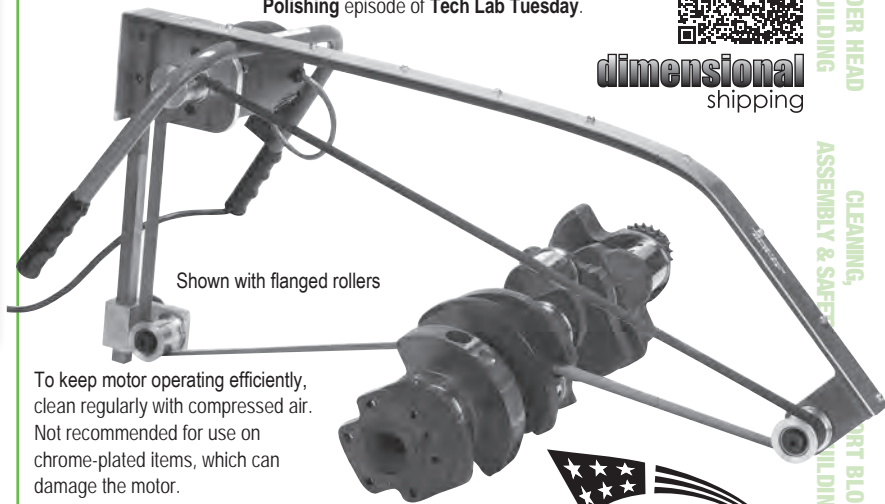

Shown with flanged rollers

To keep motor operating efficiently, clean regularly with compressed air. Not recommended for use on chrome-plated items, which can damage the motor.

Includes a sample pack of our most popular 72" Belts (PCP-72PAK)

made in America

tech tips from the techxperts™

Extend the life of your polishing belts by releasing the tension when not in use.



PCP-2S



PCP-2D



PCP-2



PCP-2-EA



PCP-2F

Adjustable 110V Crankshaft Polisher

- Adjusts to accommodate 60" to 72"L belts
- Flex resistant steel frame
- Weighs 15 lbs. (6.8 kg)
- Crowned rollers keep snug belt running true
- 1" nominal = 1.625" • 2" nominal = 2.625"
- 1/2 HP motor designed for high RPM not heavy loads
- Specify flanged or unflanged rollers when ordering
- 110V, 60Hz Motor

Roller Width		HP	Max. RPM	Order No.
Nominal	Actual			
1"/25mm	1.625"/41mm	1/2	10,000	PCP-1072
2"/51mm	2.625"/67mm	1/2	10,000	PCP-1072-2
Replacement Parts and Rollers				Includes
Flanged Roller Sets (3 piece set)	1"			PCP-1
Unflanged Roller Sets (3 piece set)	1"			PCP-1S
Flanged Drive Roller	1"			PCP-1D
Fits 3/8" shaft - 1 ea.	2"			PCP-2D
Flanged Roller Assembly 3/8" x 16 thread - 1 ea.	1"			PCP-1F
Unflanged Roller Assembly 3/8" x 16 thread - 1 ea.	1"			PCP-1-1EA
Bearing - 1 ea.	2"			PCP-2-EA
Replacement Switch				PCP-BRG
Replacement 110V, 60Hz Motor (round housing)				PCP-SWITCH-72
Retrofit Motor Adaptor (round to square housing)				PCP-MOTOR-RS
Retrofit Motor Adaptor (square to round housing)				PCP-RFK
Replacement Motor Brush Set (1 Pair)				PCP-RFK2
				PCP-BRUSH-72

CYLINDER HEAD REBUILDING
CLEANING, PART BLOCK BUILDING
FLYWHEEL GRINDING
CRANKSHAFT/
MISCELLANEOUS TOOLS & SUPPLIES
BRAKE SERVICE TOOLING
MEASURING TOOLS
V-TWIN & METRIC HARD PARTS

full service ...fast



"We make most of our abrasive belts in-house now. If you need a different size belt than you see in the catalog, give us a call. Let us make a custom belt for you."

- Justin, Abrasive Industrial Supplies Belt Technician, 1 year of service



video
available

Watch the Tech Lab Tuesday video in which we explain why we offer so many crank polishing belts.

Scan the code below with your smart phone or other smart device for instant access to the video.



Micro Finish



Scotch-Brite Style Abrasive Rolls

- Ideal for hand polishing of high-performance crankshafts
- Non-directional polish
- Won't remove material
- Aluminum oxide abrasive
- Measures: ¾"x10' • 1 Per Box
- Order No. **GFR-750**

Premium Ceramic

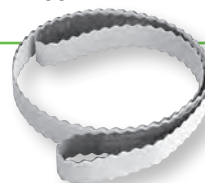

Micro Polishing Belts

- Use with Polishing rouge to achieve high luster finish
- Structured Abrasive • 5 per box

Size (LxW)	Order No.
60" x 1"	GSW-60x1
64" x 1"	GSW-64x1
72" x 1"	GSW-72x1
77" x 1"	GSW-77x1
Polishing Rouge	CPR-16

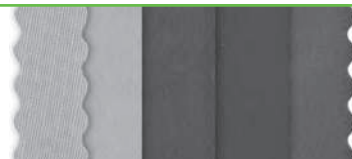

Crankshaft Polishing Belt Sample Pack

These sample packs include our most popular belts. Contents may vary.

Long	Wide	Qty.	Order No.
64"	1"	5	PCP-64PAK
72"	1"	5	PCP-72PAK
72"	2"	2	PCP-72PAK-2

240 to 600 Grit Premium Ruby Aluminum-Oxide Crankshaft Polishing Belts

- Ruby Aluminum-Oxide abrasive specifically for use on metal
- Closed coat J-weight cloth backing with high strength joint
- Phenolic resin-over-resin bond
- Polish better and outlast other standard polishing belts
- Color may vary due to manufacturing process

		STRAIGHT-EDGE (10 per box)			
L	W	240 Grit	320 Grit	400 Grit	600 Grit
60"	¾"	R60x¾x240	R60x¾x320	R60x¾x400	R60x¾x600
	1"	R60x1x240	R60x1x320	R60x1x400	R60x1x600
	2"			R60x2x400	
64"	¾"	R64x¾x240	R64x¾x320	R64x¾x400	R64x¾x600
	1"	R64x1x240	R64x1x320	R64x1x400	R64x1x600
	1¼"		R64x1¼x320	R64x1¼x400	R64x1¼x600
	1½"	R64x1½x240		R64x1½x400	R64x1½x600
	1¾"	R64x1¾x240	R64x1¾x320		
72"	¾"	R72x¾x240	R72x¾x320	R72x¾x400	R72x¾x600
	1"	R72x1x240	R72x1x320	R72x1x400	R72x1x600
	1¼"	R72x1¼x240	R72x1¼x320	R72x1¼x400	R72x1¼x600
	1½"		R72x1½x320	R72x1½x400	R72x1½x600
	1¾"	R72x1¾x240	R72x1¾x320	R72x1¾x400	R72x1¾x600
77"	1"		R77x1x320	R77x1x400	R77x1x600
	1¼"			R77x1¼x400	
	1½"			R77x1½x400	
	2"		R77x2x320	R77x2x400	R77x2x600

All abrasives are guaranteed for 1 year from the original purchase date

Need a size not listed in the chart? We can do that!

Goodson division, Abrasive Industrial Supplies, makes abrasive belts to order. Whether you're looking for other sizes of polishing belts or you need something to fit a grinder in your shop, they're available. Check out www.AbrasiveIndustrialSupplies.com or ask your customer service representative for more information.



3M™ Trizact™ Crankshaft Polishing Belts

- X-Weight cloth belt • A45 micron – equivalent to 400 grit
- Structured abrasive grains are perfectly shaped pyramids bonded at equal spacing to a high-strength polyester backing • Uniform wear for better performance and long life • Produce a high-luster finish • 5 per box

Size	Jobber	Order No.
64" L x 1" W		GSA-64x1
72" L x 1" W		GSA-72x1

Blue 800 Grit Crankshaft Polishing Belts With Scrum Back

- Film substrate with aluminum-oxide abrasive
- 10 belts per box
- High quality joint with scrum back
- Highly flexible and long lasting

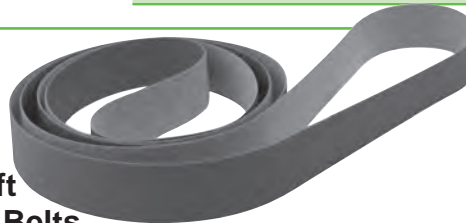

Size	Order No.
60" x ¾"	BF-60X3/4X800
60" x 1"	BF-60X1X800
64" x ¾"	BF-64X3/4X800
64" x 1"	BF-64X1X800
72" x ¾"	BF-72X3/4X800
72" x 1"	BF-72X1X800
77" x 1"	BF-77X1X800

Crankshaft Polishing Belts



10 Belts
Per Box

240, 320 & 400 Grit Standard Polishing Belts

- US CAMI Grade aluminum-oxide abrasive
- 2-layer glue bond • Fast break-in
- Use with Polishing Rouge (CPR-16) for better finish
- Highly flexible J-Weight cloth backing
- Less aggressive belts for polishing

STANDARD STRAIGHT-EDGE (10 per box)				
Lgth	Width	240 grit	320 grit	400 grit
60"	3/4"	60x3/4x240	60x3/4x320	60x3/4x400
	1"	60x1x240	60x1x320	60x1x400
	1 1/4"		60x1 1/4x320	
64"	3/4"	64x3/4x240	64x3/4x320	64x3/4x400
	1"	64x1x240	64x1x320	64x1x400
	1 1/4"		64x1 1/4x320	
	1 1/2"	64x1 1/2x240	64x1 1/2x320	
	1 3/4"		64x1 3/4x320	
70"	2"	64x2x240	64x2x320	64x2x400
	3/4"		70x3/4x320	
	1"	70x1x240	70x1x320	70x1x400
	1 1/4"			70x1 1/4x400
72"	1 1/2"			70x1 1/2x400
	3/4"	72x3/4x240	72x3/4x320	72x3/4x400
	1"	72x1x240	72x1x320	72x1x400
77"	1 1/4"	72x1 1/4x240	72x1 1/4x320	
	1 1/2"	72x1 1/2x240	72x1 1/2x320	72x1 1/2x400
	1 3/4"	72x1 3/4x240		
	2"	72x2x240	72x2x320	72x2x400
	3/4"		77x3/4x320	77x3/4x400
77"	1"	77x1x240	77x1x320	77x1x400
	1 1/2"		77x1 1/2x320	
	1 3/4"			77x1 3/4x400
	2"	77x2x240	77x2x320	

All abrasives are guaranteed for 1 year from the original purchase date

Need a size not listed in the chart? We can do that!

Goodson division, Abrasive Industrial Supplies, makes abrasive belts to order. Whether you're looking for other sizes of polishing belts or you need something to fit a grinder in your shop, they're available. Check out www.AbrasiveIndustrialSupplies.com or ask your customer service representative for more information.

Standard Scalloped Edge Crankshaft Polishing Belts

- 10 per box • 320 grit • 1" wide
- Ideal for radius polishing
- Double layer urea glue bond CAMI grade polishing belts

Length	Order No.
64"	S64x1x320
72"	S72x1x320



Fine Finish

- Gold Aluminum-oxide • Flexible, woven blue backing • **Very** aggressive
- Phenolic Resin-Over-Resin bond
- Sharper grains cut faster without sacrificing finish • Use with Grind Aid (GRA-10) or Polishing Rouge (CPR-16) for cooler polishing or grinding



Custom
Belt Sizes Available

Fine Finish (10 per box)

Length	Width	320 grit	400 grit
60"	1"	G-60x1x320	G-60x1x400
64"	1"	G-64x1x320	G-64x1x400
72"	1"	G-72x1x320	G-72x1x400
77"	1"	G-77x1x320	G-77x1x400

Scotch-Brite Style Micro Finish

- Rigid, 3-dimensional back • Resin bond • Aluminum-oxide abrasive • Non-directional Satin finish
- Use with Grind Aid (GRA-10)

Micro-Finish (1 per box)

Length	Width	Order No.
60"	3/4"	GFB-60 x 3/4
	1"	GFB-60 x 1
64"	3/4"	GFB-64 x 3/4
	1"	GFB-64 x 1
70"	3/4"	GFB-70 x 3/4
	1"	GFB-70 x 1
72"	3/4"	GFB-72 x 3/4
	1"	GFB-72 x 1
77"	1"	GFB-77 x 1
	91"	1"

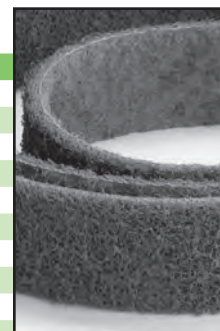

Scotch-Brite Style Super-Micro Finish

- Produces a mirror-like non-directional finish
- Resin bond • Silicon-Carbide abrasive
- For final Satin finish • Use with Grind Aid (GRA-10)

Super-Micro Finish (1 per box)

Length	Width	Order No.
60"	3/4"	SGFB-60 x 3/4
	1"	SGFB-60 x 1
64"	3/4"	SGFB-64 x 3/4
	1"	SGFB-64 x 1
70"	3/4"	SGFB-70 x 3/4
	1"	SGFB-70 x 1
72"	3/4"	SGFB-72 x 3/4
	1"	SGFB-72 x 1
77"	3/4"	SGFB-77 x 3/4
	1"	SGFB-77 x 1

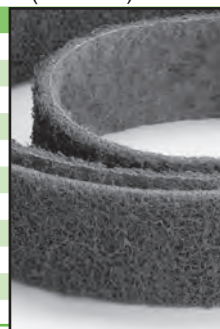

800 Grit Abrasive Cork Super-Fine Finish

- Won't disturb polished radii
- Silicon-carbide • Use with Polishing Rouge (CPR-16) for High Luster finish

Abrasive Cork (1 per box)

Length	Width	Order No.
64"	3/4"	CPB-64-3/4
	1"	CPB-64-1
70"	3/4"	CPB-70-3/4
	1"	CPB-70-1
72"	3/4"	CPB-72-3/4
	1"	CPB-72-1
77"	3/4"	CPB-77-3/4
	1"	CPB-77-1



Need A Size You Don't See? Give Us A Call; We Make Most Belts In-House!

... another satisfied customer



"Goodson was able to help me select the right grinding stones for our racing clutch and flywheel program. Their support and technical advice is always available to keep our program on the right track."

- Johnny Ahten, Johnny Ahten Racing - Goodson customers since 2005

CYLINDER HEAD REBUILDING

CLEANING, ASSEMBLY & SAFETY

SHORT BLOCK REBUILDING

CRANKSHAFT/ FLYWHEEL GRINDING

MISCELLANEOUS TOOLS & SUPPLIES

BRAKE SERVICE TOOLING

MEASURING TOOLS

V-TWIN & METRIC HARD PARTS

Flywheel Radius Cutter Tip Holder

- For Winona Van Norman/ Van Norman FG-5000
- Holder measures 1.5"L with a .312" dia. shank
- Includes 1 indexable FG-3B cutter tip

Description	Order No.
Tip Holder	FG-5011
Replacement Tip	FG-3B

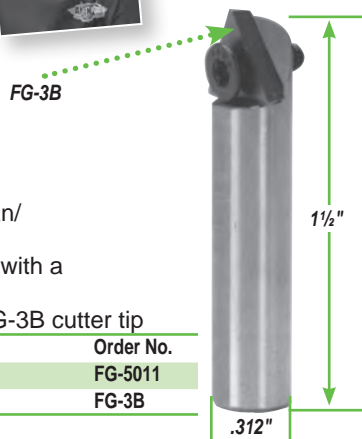

Flywheel Grinding Coolant

- Formula eliminates rancid coolant
- Synthetic inhibitors
- Dilute 30:1 (water:coolant)

Size	Order No.
1 Gal. / 3.78L	FG-1101-G
5 Gal. / 18.8L	FG-1102-G



Flywheel Cutter Tip For Winona Van Norman 570 Rotary Broach

- 3-edge carbide cutting tip for use with the special flywheel attachment
- Order VN-FW

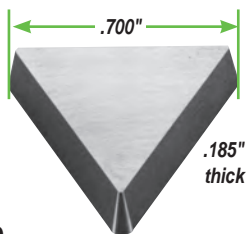

Flywheel Depth Gauge with Dial Indicator

- Measure flywheel before and after grinding to maintain proper depth specifications
- Gauge Assembly includes Dial Indicator, Bar & Magnets
- Spindle Extensions sold separately

Description	Order No.
Gauge Assembly	FGG-12
Spindle 1.5"	DIS-1.5
Extensions 2.5"	DIS-2.5
3.0"	DIS-3.0

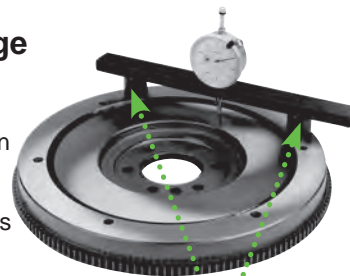

Magnetic feet adjust to flywheel diameter

Flywheel Grinder Bolt Adaptors

- Replace shoulder bolts with standard hardware
- Low-cost adaptor converts any 1/2" or 7/16" bolt to a 3/4" ID
- Includes countersunk adaptor with bolts for extra clearance



Fits	Size	Order No.
DCM, Peterson, KW	1/2" x 13	FG-DCP-KIT
WVN	7/16" x 14	FG-AB-KIT
WVN Table Insert	OD: 5/8" x 11, ID: 7/16" x 14	FG-LOCK

Flywheel Grinder Table Lubricant

- Extend flywheel grinder life
- High pressure oil designed to lubricate table bearings and ways
- For all makes of flywheel grinders
- 1 Gal. (3.78L)
- Order No. FG-1131-G

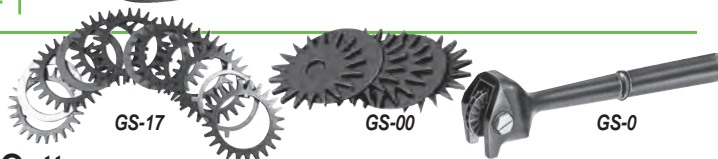
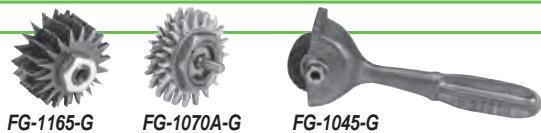

Diamond Dresser Tools are available on pages 114-115

Grinding Wheel Dressers & Replacement Cutters

Applications	Cutter Assemblies			Replacement Cutters					
	OD	W	Order No.	Pieces	Washers	OD	ID	Thick	Order No.
Peterson (12mm shaft)				8 stars	3	2.375"	1.50"	.093"	GS-17
					1 w/locking tangs	1.75"	1.50"	.060"	
WVN SM2000, 4000, 5000, 6000C, 6000A, MG3000, 3850	1.250"	.978"	FG-1165-G	7 stars	none	1.25"	0.313"	.095"	FG-1161-G
Peterson & DCM	2.375"	2.262"	FG-1070A-G	5 stars		2.375"	1.132"	.1375"	FG-1070-G
Hand held			FG-1045-G	1 stone	none	1.50"	0.313"	.6250"	FG-1044-G
Desmond Dresser for wheels to 10"			GS-0	4 blades, 2 spacers			0.250"		GS-00
				4 blades, 2 spacers			0.500"		GS-11

Crankshaft & Flywheel Tools

Petroleum Based Valve Lapping Compound

- Silicon-carbide, grease-based compound
- Petroleum based valve lapping compound facilitates precise mating between valve seats and valves
- Use with any powered or manual valve lapping tools
- The higher the number, the finer the grit



Size	Grit	Order No.
2 oz. / 56.7g	400 Grit	VLC-2-400
	600 Grit	VLC-2-600
	800 Grit	VLC-2-800
	1200 Grit	VLC-2-1200

More lapping compounds on page 17

tech tips

from the techxperts™

Put a dab of valve lapping compound on a dowel pin that just won't come out, then use your puller to extract it. The grit in the lapping compound gives you more grip so you can successfully pull stubborn dowels.

Pin Pal Puller

- Remove dowels fast
- Adjusts to pull all sizes of dowels
- Locking pliers with special hardened jaws hold firm while 4 lb. slide hammer forces dowels out
- Also pulls pressed-in hollow tubes or frozen shafts
- Rugged steel construction

Description	Order No.
Complete Tool	GA-300
Replacement Jaws	GA-300E-R



Mirrored Safety Glasses

- Wrap-around design
- Tinted lenses provide sun glare protection
- Universal bridge
- Polycarbonate lenses
- Do not use as welders helpers
- Order No. PGL-21



Heavy Metal

An essential component when balancing rods & pistons to crankshafts to ensure proper engine operation. Contains 90% Tungsten



HEAVY METAL - TUNGSTEN 90%					
Hole in	Press Fit + in/mm	1.0" Long Grams	Order No.	1.2" Long Grams	Order No.
1/2"	.002"/.05	57	HM-57	65	HM-72
3/4"	.002"/.05	122	HM-122	147	HM-162
7/8"	.002"/.05	169	HM-169	198	HM-198
1"	.002"/.05	227	HM-227	265	HM-265

NOTE: Due to market fluctuations, heavy metal prices are subject to change without notice. Please confirm pricing when ordering.

tech tips

from the techxperts™

It is essential, when pulling a dowel, that the tightening sleeve is installed with the flared end toward the collet. This will allow the tightening sleeve to slide over the collet, locking it to the dowel you are removing. Also, be sure to select the correct collet size for the dowel you are removing.



video available

Scan the code below on your smart phone or other smart device to watch our How-To video on Dowel Pulling.



Dowel Puller and Collets

- Slide hammer action removes stubborn dowels
- Use on blocks, heads, flywheels, etc.
- Split collets grip firmly without causing damage
- A high-quality tool that lets you reuse dowel pins
- Choose from SAE or Metric kits
- All items also sold separately

Description	Order No.	Incl.		
Standard Kit	GA-600	▼		
Metric Kit	GA-600M	▼		
Slide Shaft (14" L)	GAO-1	x x		
Slide Hammer	GAO-2	x x		
Tightening Sleeve	GAO-3	x x		
Gripping Collets				
OD	ID	mm		
1"	.1575"	4.00	GAO-22	x
1"	.1875"	4.76	GAO-4	
1"	.1969"	5.00	GAO-13	x
1"	.2362"	6.00	GAO-14	x
1"	.2500"	6.35	GAO-5	x
1"	.2756"	7.00	GAO-26	
1"	.3125"	7.94	GAO-6	x
1"	.3150"	8.00	GAO-10	x
1"	.3750"	9.53	GAO-7	x
1"	.3937"	10.00	GAO-23	
1"	.4375"	11.11	GAO-8	x
1"	.4724"	12.00	GAO-24	
1"	.5000"	12.70	GAO-9	
1"	.6250"	15.88	GAO-20	
Removal Basin	GAO-21	x x		

Parts are stamped for easy identification & reordering

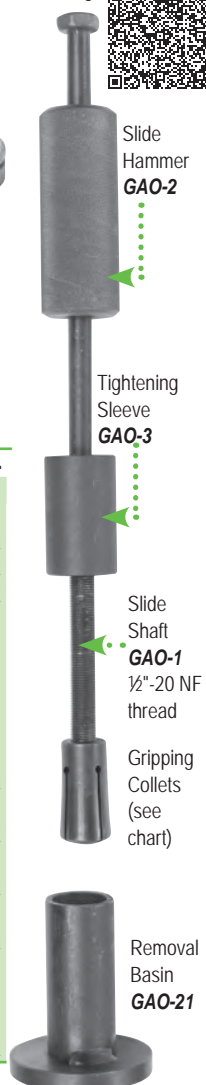

CYLINDER HEAD REBUILDING
CLEANING, ASSEMBLY & SAFETY
SHORT BLOCK REBUILDING
CRANKSHAFT/FLYWHEEL GRINDING
MISCELLANEOUS TOOLS & SUPPLIES
BRAKE SERVICE TOOLING
MEASURING TOOLS
V-TWIN & METRIC HARD PARTS



"Every Goodson crankshaft grinding wheel is made-to-order. We ensure every wheel is checked and double checked for accuracy."

- Dylan, Goodson Production, 1 year of service



video available Goodson carries a wide selection of flywheel grinding stones. Watch as we unpack the reasons why in our **Tech Lab Tuesday** video "Choosing the Right Flywheel Stone." Scan the code at right with your smart phone or other smart device for instant access.

Coolant on pages 74 and 110

CYLINDER HEAD
REBUILDING

CLEANING,
ASSEMBLY & SAFETY

SHORT BLOCK
REBUILDING

CRANKSHAFT/
FLYWHEEL GRINDING

MISCELLANEOUS
TOOLS & SUPPLIES

BRAKE SERVICE
TOOLING

MEASURING
TOOLS

V-TWIN & METRIC
HARD PARTS

For Best Results... Choose The Right Flywheel Stone From Goodson

Goodson stones feature 50% more usable abrasive and much stronger construction, yet sell at prices comparable to ordinary stones. With Goodson stones you'll get longer wheel life and lower-cost flywheel grinding.

Cast Iron:

Cast Iron (soft) flywheels need to be ground with harder stones. Experiment to find the best stone. A starting point is the FGW-57, our best all-around stone for Cast Iron.

Cast Steel:

Cast Steel (medium) flywheels require medium-hard stones. The FGW-65 is our best all-around stone for Cast Steel.

Billet Steel:

Billet Steel (very hard) flywheels need to be ground with softer stones. Our best all-around stone for Billet Steel is the FGW-50-2. It's our most friable and free-cutting, requiring minimal dressing.

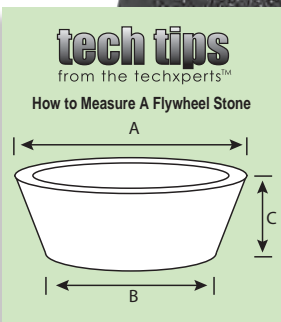

tech tips from the techxperts™ Be sure to use ample coolant to flush away swarf and help the stones perform better.

Silicon-Carbide Abrasive

CAST IRON (Passenger cars, light trucks)

A	B	C	Arbor	Description	Order No.
6"	4½"	2½"	1¼"	Harder than FGW-57, lasts longer, black	FGW-67
6"	4½"	2½"	1¼"	Best all-around for cast iron, black	FGW-57
6"	—	2½"	1¼"	Straight-sided FGW-57, black	FGW-57S
6"	4½"	2½"	1¼"	Softer than FGW-57, grinds faster, black	FGW-47
6"	4¾"	2⅞"	1¼"	Silicon-carbide, ideal for top fuel, black	FGW-37
6"	4¾"	2⅞"	1¼"	Silicon-carbide, softer, finer grit than FGW-37	FGW-37F
4"	3"	2"	1¼"	Small diameter FGW-57, black	FGW-61
4"	3"	2"	1¼"	Small diameter FGW-37, black	FGW-374
3"	—	2"	1¼"	Straight-sided green silicon-carbide, premium	FGW-93

Silicon-Carbide/Aluminum-Oxide Combination

CAST STEEL (Industrial, agricultural, OTR trucks)

A	B	C	Arbor	Description	Order No.
6"	4½"	2"	1¼"	Harder than FGW-65 lasts longer, lt. gray	FGW-53
6"	4½"	2½"	1¼"	Best all-around for Cast Steel, speckled	FGW-65
6"	4½"	2½"	1¼"	Slightly softer than FGW-65, black	FGW-495
4"	3"	2"	1¼"	Small diameter FGW-65, speckled	FGW-69
6"	4½"	2½"	1¼"	Softer than FGW-65, grinds faster, black	FGW-49

Aluminum-Oxide Abrasive

BILLET STEEL (Import vehicles, high-performance)

A	B	C	Arbor	Description	Order No.
6"	4½"	2½"	1¼"	Harder, ruby stone, lasts longer	FGW-64
6"	4½"	2½"	1¼"	Harder, pink stone, lasts longer	FGW-62-1
6"	4½"	2½"	1¼"	Harder than FGW-50-2	FGW-50
6"	4½"	2½"	1¼"	Best all-around for Billet Steel	FGW-50-2
4"	3½"	1½"	1¼"	Harder, pink stone, lasts longer	FGW-63-1
4"	3"	2"	1¼"	Taller than FGW-56, more abrasive, white	FGW-306
4"	3½"	1½"	1¼"	Premium	FGW-56P
4"	3½"	1½"	1¼"	Small diameter, off white	FGW-56
3"	2¼"	1¼"	¾"	Small diameter, light gray	FGW-59
3"	—	2"	1¼"	Straight-sided sugar white stone	FGW-92

NOTE: Due to manufacturing process, colors may vary.

All abrasives are guaranteed for 1 year from original purchase date.

Mounting Adaptor For Small Diameter Stones

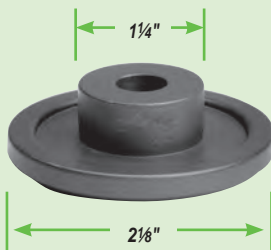

- Many flywheel grinders have lower mounting flanges that won't fit inside 3" and 4" diameter flared-cup stones
- Use this adaptor to avoid damage when mounting small stones
- Fits most small diameter stones
- Order No. **FG-FLANGE**

tech tips

from the techxperts™

Use a 3/8" Cap Screw & Washer to mount 2" & 3" Diameter CBN Flywheel Grinding Wheels to Your Flywheel Grinder



FlyMaster® CBN Super Abrasive Flywheel Grinding Wheels

• For cast iron • Light to heavy applications

A	B	C	Arbor	Shape	Grit	Order No.
2"	2"	0.4"	3/8"	Straight	100	CBN-200
3"	3"	0.4"	3/8"	Straight	100	CBN-300
2"	1 3/8"	7/8"	3/8"	Cup	100	2H0998
3"	2"	1 1/4"	1 1/4"	Cup	100	261453
3 3/4"	2 5/8"	1 1/2"	1 1/4"	Cup	100	2371052
3 3/4"	2 5/8"	1 1/2"	1 1/4"	Cup	60	34296362
5"	3 3/4"	1 3/4"	1 1/4"	Cup	100	2379270
6"	4 5/8"	1 5/8"	1 1/4"	Cup	100	2367275*
6"	4 5/8"	1 5/8"	1 1/4"	Cup	60	2G7480
CBN Dressing Stick 1/2" x 1/2" x 6"						DS-CBN

*Most popular application

tech tips

from the techxperts™

How to Measure A Flywheel Stone

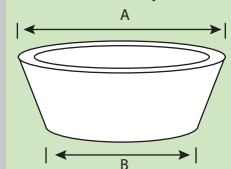

tech tips

from the techxperts™

Never dress your Superabrasive with the dresser attachment on your machine. Use our CBN dressing stick for best results.

Flywheel Grinding Stones

• Four Abrasive formulas to choose from

SILICON-CARBIDE ABRASIVE

Ductile Iron, Cast Iron & Steel (Black)

A	B	C	Arbor	Hardness	Shape	Order No.
3"	2 1/2"	1 1/2"	1 1/4"	Med. Hard	Flared	U364512
4"	3"	2"	1 1/4"	Med. Soft	Flared	U335369
6"	4 1/2"	2 1/2"	1 1/4"	Med. Soft	Flared	U324495
6"	4 1/2"	2 1/2"	1 1/4"	Med. Hard	Flared	U335376
6"	4 1/2"	2 1/2"	1 1/4"	Hard	Flared	U335377
6"	4 1/2"	2 1/2"	1 1/4"	Med. Soft	Flared	U357854
6"	4 1/2"	2 1/2"	1 1/4"	Med. Hard	Flared	U343805

EXTENDED LIFE CERAMIC

Ductile Iron, Cast Iron and Steel (Black)

A	B	C	Arbor	Hardness	Shape	Order No.
6"	4 1/2"	3"	1 1/4"	Med. Hard	Flared	U370095

ALUMINUM-OXIDE ABRASIVE

Mild Steel & Hardened Steel (White)

A	B	C	Arbor	Hardness	Shape	Order No.
6"	4 1/2"	2 1/2"	1 1/4"	Soft	Flared	F342636

ALUMINUM-OXIDE ABRASIVE

Light to Medium Stock Removal on Steel, Cast Iron & Ductile Iron (Ruby)

A	B	C	Arbor	Hardness	Shape	Order No.
4"	3"	2"	1 1/4"	Medium	Flared	F348769
6"	4 1/2"	2 1/2"	1 1/4"	Soft	Flared	F372039
6"	4 1/2"	2 1/2"	1 1/4"	Med. Soft	Flared	F348771
6"	4 1/2"	2 1/2"	1 1/4"	Medium	Flared	F348772
6"	4 1/2"	2 1/2"	1 1/4"	Hard	Flared	F348773

Colors may vary due to the manufacturing process

Diamond Flywheel Grinding Wheel

- For hard, spray coated floaters and flywheels
- **Not for use on cast iron or steel flywheels**
- A = 6" | B = 4 5/8" | C = 1 7/8" | Arbor = 1 1/4"
- Order No. **2E5742**



3/4" Thick Wall for Faster, More Aggressive Grinding

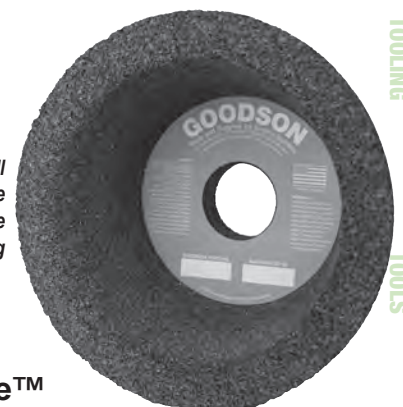

Big Brute™ Flywheel Grinding Stone

- Medium-Hard Silicon Carbide abrasive formula • Extra beefy for better grinding
- Measurements: A = 6" | B = 4 3/4" | C = 3" | Arbor = 1 1/4" (see graphic above)
- Order No. **U69693**

CYLINDER HEAD REBUILDING
CLEANING, ASSEMBLY & SAFETY
SHORT BLOCK REBUILDING
CRANKSHAFT/ FLYWHEEL GRINDING
MISCELLANEOUS TOOLS & SUPPLIES
BRAKE SERVICE TOOLING
MEASURING TOOLS
V-TWIN & METRIC HARD PARTS

Diamond Dresser Tools

shown at approximately full size

CYLINDER HEAD
REBUILDING

CLEANING,
ASSEMBLY & SAFETY

SHORT BLOCK
REBUILDING

CRANKSHAFT/
FLYWHEEL GRINDING

MISCELLANEOUS
TOOLS & SUPPLIES

BRAKE SERVICE
TOOLING

MEASURING
TOOLS

V-TWIN & METRIC
HARD PARTS



Diamond: Selected for very high point definition. A sharper diamond cuts faster and gives a superior finish.

Matrix: Matrix material is bronze or copper-based for a tight hold on the diamond & high heat transfer.

Holder: Cold rolled steel. Threaded types have precision threads over a long distance to screw easily into tool holders and support cutting point firmly to prevent vibration.

Diamonds are stamped for easy identification and re-ordering

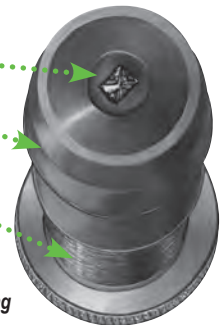

Premium Diamond Resetting Service:

Send your worn premium diamonds to Goodson for fast resetting. Prices quoted upon request. Reset when wear facets exceed $\frac{1}{16}$ " on a $\frac{1}{2}$ to $\frac{3}{8}$ carat diamond and $\frac{1}{8}$ " on a 1 carat or larger.

Diamond Dresser Tools

Diamond Dressers for most shop machines are in stock and ready-to-ship



A diamond tool is only as good as the diamond itself. GOODSON diamonds are furnished by the most respected supplier in the U.S. Each is subjected to a microscopic examination by experts and must meet strict standards to be accepted. This rigorous inspection and careful control during manufacturing assures consistent high quality. Our diamond tools deliver the highest levels of performance and longevity.

In addition to our standard diamond tools, GOODSON stocks a wide selection of Premium Quality Diamonds. These diamonds last longer and improve wheel performance. They stay sharp longer and have more points so they can be reset more times. Because of this quality, they will dress harder wheels and wheels will need to be dressed less frequently. If you don't see the diamond you need in a premium quality, call 1-800-533-8010 for a special order.

	Machine	Description	Carat	Standard	Premium
Valve Refacers	B&D, Skil, Sioux™, Thor, VanDorn, WVN	3/8" x 1 1/8"	1/5	G-1	G-1P
	Kwik-Way, Tobin Arp (S&D)	5/16" x 2 1/2"	1/5	G-3	—
	Kwik-Way, Valve Master (1714)	1/2" x 3 1/4" 20NF	1/5	G-4	—
	Sioux™ (1713, 1715), IDL, WVN (CG50, CG80)	3/8" x 2 3/4" 24NF	1/5	G-5	G-5P
	IDL, WVN (CG50, CG80)	3/8" x 3 1/4" 24NF	1/5	G-80	—
	US	7/16" x 2"	1/5	G-6	—
	Skil (Talent)	5/16" x 2 1/4" 18NC	1/5	G-9	—
	Kwik-Way	7/16" x 2 3/4" 20NF	1/5	G-17	G-17P
Valve Seat Grinders	B&D, S&D, Van Dorn	3/8" x 2 1/4" 24NF	1/5	G-2	—
	Kwik-Way	1/2" x 3 1/4" 20NF	1/5	G-4	—
	Sioux™ (1715), K-W (NSG), Thor	3/8" x 2 3/4" 24NF	1/5	G-5	G-5P
	Hall HD (13-1938P), Skil, Snap-On, B&D	5/16" x 2 1/4" 24NF	1/5	G-8	G-8P
	KO Lee, Skil	5/16" x 2 1/4" 18NC	1/5	G-9	—
	Sioux™ Heavy Duty (1715B, 1719)	3/8" hex RH thread	1/5	G-11	—
	Goodson Universal Wheel Dresser	8mm x 1.25mm	1/5	—	G-13P
	Sioux™ Heavy Duty (1715A)	3/8" x 2 3/4" 24NF	1/2	G-15	—
Clutch Grinders	Kwik-Way Heavy Duty Wheel Dresser	1/2" x 3" 20NF	1/5	G-18	G-18P
	Lempco AC, NAC, VAC & Do-ALL	7/16" x 2"	1/5	G-6	—
Piston Grinders	Van Norman 75, 76 & Relio	3/8" x 1 1/8"	1/5	G-1	G-1P
	Storm-Vulcan D-3	7/16" x 2"	1/5	G-6	—
Drum Lathes	Van Norman (all except 302, 302H)	3/8" x 1 1/8"	1/5	G-1	G-1P
	Barret, V.N. 302, 302H	3/8" x 3"	1/5	G-1L	—
	Lempco	7/16" x 2"	1/5	G-6	—
	Ammco 5000	1/2" x 1 1/2"	1/5	G-19	—
Rod Grinders	Sunnen® Rod & Cap Grinder (CRG-500)	3/8" x 1 1/8"	1/5	G-1	G-1P
	Storm-Vulcan No. 65 Rod Grinder	1/2" x 3 1/4" 20NF	1/5	G-4	—
Crank & Cam Grinders	Storm-Vulcan 14, 15, 15A, 15C, 75, 75A	1/2" x 3"	3/4	G-25	—
		1/2" x 3"	1	G-25A	—
	Scledum	10mm x 1 1/8"	3/4	G-27	—
	Winona Van Norman/Zanrosso,	7/16" x 1 1/4", 5/8" head	3/4	G-30	—
	Lempco, Landis	7/16" x 1 1/4", 5/8" head	1	G-30A	—
	Berco	tapered, step type	1	G-32A	G-32AP
	Berco	tapered, step type	1 1/2	G-32B	—
	Storm-Vulcan, WVN CG210, 250, 280	1/2" x 2" 70° radius dress	3/4	G-33	—
Flywheel Grinder	Kwik-Way 796	7/16" x 2"	1/5	G-6	—

tech tips

from the techxperts™

- 1. Set tool at a proper angle.** Position at 10° to 15° from surface. Smaller angles blunt the diamond. Larger angles may cause the wheel to remove matrix material.
- 2. Prevent vibration in the holder.** Any looseness in the tool holder will allow vibration of the tool resulting in poor finish on the wheel.

- 3. Turn coolant on before dressing.** Wheels used wet should be dressed wet. To keep diamond cool, turn coolant on before starting to dress. (If wheel is dressed dry, air-cool diamond between cuts but don't quench with water.)
- 4. Start at highest point.** Wheels often wear unevenly & may have high & low spots. Set tool to dress high spots first, feed in about .001" per pass until done. This prevents overheating & damage.

- 5. Use steady travel.** Uneven travel causes an uneven finish. The best rate is found by experiment, but whatever the rate of travel, it must be even.
 - 6. Turn the tool in the holder.** Turn the tool often to expose new diamond surface to the wheel.
 - 7. Don't bump or drop diamond.** They are hard but brittle, and can be harmed if dropped or bumped.
- CAUTION: Grinding Wheel must never touch the matrix or holder.**

CYLINDER HEAD
REBUILDING
CLEANING,
ASSEMBLY & SAFETY
SHORT BLOCK
REBUILDING
FLYWHEEL GRINDING
CRANKSHAFT/
MISCELLANEOUS
TOOLS & SUPPLIES
BRAKE SERVICE
TOOLING
MEASURING
TOOLS
V-TWIN & METRIC
HARD PARTS



14mm Spark Plug Thread Chaser/Burnisher

- Ideal for spark plug hole cleaning
- Re-forms the original material by burnishing, not cutting, and won't create new chips to clean out
- Order No. **SPB-14**

Burr Buster

- Use on air float tables, seat & guide machines, beds of crankshaft grinders and flywheel grinder tables
- Deburrs gasket surfaces on heads, blocks, manifolds, etc.
- 120 grit premium grade abrasive
- 1½" x 2¾" x 9"
- Order No. **BB-9**



Premium Tapered Reamer

- Use by hand or with a powered driver to deburr or enlarge tapered holes for valve guides, bolt hole chamfering, and more • Degree of Taper: 2.86°
- Use in ½" chuck at approx. 40 RPM
- OAL: 5¾" • Flute Length: 3¾"
- Small End: 1/8" dia.
- Large End: 1/2" dia.
- Order No. **TR-216-1**



Maxxeon® WorkStar® 364 USB Rechargeable UV Leak Detection Pen/Inspection Light

- 3.7V Lithium battery with USB charger
- Run time: 35 min. continuous, 2 hr. intermittent operation
- Use with Goodson Glow or Magnetic Crack Detection Oil (page 53) • Dust-tight, waterproof to 3 feet
- Easily adjustable beam to suit application
- Drop tested to 6 feet
- Order No. **DFL-364**



Maxxeon® WorkStar® 360 Rechargeable LED Pen/Inspection Light

- No batteries to replace! Includes Micro USB charger
- 3X zoom provides 160 lumens on low
- 1X zoom provides 260 lumens on high
- 40 minute continuous or 2-hour intermittent operation
- Dust-tight, waterproof to 3 feet
- Drop tested to 6 feet
- Order No. **DFL-360**

Maxxeon® WorkStar® 810 CYCLOPS Rechargeable LED Work Light

- Puts the light right where you need it • Drop tested to 6 feet
- LiPo battery with USB charger
- 3 light settings
- Magnetic base attaches the light to your machine
- Water resistant, do not immerse
- Order No. **DFL-810**

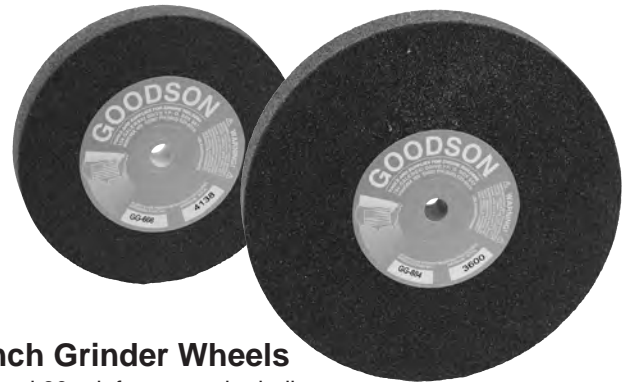

Bench Grinder Wheels

- 40 and 60 grit for general grinding
- 100 grit for sharpening carbide tools
- Includes bushings to reduce arbor hole from ¾" to ½" PLUS a 5/8" bushing adaptor

Size	Grit	Order No.
General Purpose Wheels: For steel and cast iron		
6" x ¾"	60	GG-666
6" x 1"	60	GG-686
8" x 1"	60	GG-886
Green Grit Wheels: For sharpening carbide tools		
6" x ¾"	100	GGC-661
6" x 1"	100	GGC-681



Grinding Wheel Star Dressers

Description	Order No.
Desmond Hand Dresser for Wheels to 10" Dia.	GS-0
Replacement Cutter Sets	
4 Blades, 2 Spacers, ¼" ID for GS-0 dresser	GS-00
4 Blades, 2 Spacers, ½" ID for GS-1 dresser	GS-11

Deburring Wheels for Bench Grinders

- Medium-hard wheels are better suited for heat sensitive materials
- Use to clean and polish white metal
- Buff and Blend Wheels deliver the same results as a wire brush but are much safer to work with



Description	Size	Qty.	Order No.
Medium-Hard Deburring Wheel	6" x 1" x 1"	1	SCW-68M
Buff and Blend Wheels	6" x ½" x 1"	5	BBD-65

Brake Lathe Replacement Tips

Tips Are Shown Actual Size

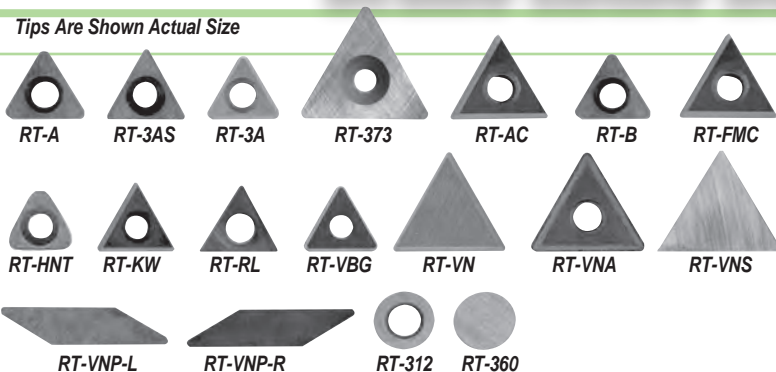

Solid Carbide

These standard grade, solid carbide cutting tips are parallel ground for resurfacing cast iron drums and rotors.

Honed Edge Carbide

Parallel & peripheral ground. Deliver a better finish on cast iron and composite rotors.

Titanium

Premium grade titanium coated carbide. Parallel and peripheral ground for ultimate performance on cast iron & composite rotors.

10 Pack Brake Lathe Replacement Tips

Machine	Model(s)	OE No.	Edges	Rake	Screws	Order No.	Order No.	Order No.
Ammco	700, 710, OTC Lathes, 1000, 2002, 3000, 4000, 4100, 7000, 7500, 7700	6914	6	Neg	Yes	RT-A-10	RT-A-H-10	RT-A-T-10
	3850 smaller (1/4") radius	6918	3	Pos	Yes	RT-3AS-10	RT-3AS-H-10	RT-3AS-T-10
	larger (1/2") radius	7681	3	Pos	Yes	RT-3A-10	RT-3A-H-10	RT-3A-T-10
Twin Cutters:	6900,6950 negative rake (std.)	6914	6	Neg	Yes	RT-A-10	RT-A-H-10	RT-A-T-10
	positive rake (standard) 1/4" (finer finish)	6918	3	Pos	Yes	RT-3AS-10	RT-3AS-H-10	RT-3AS-T-10
	positive rake (modified) 1/2" (more durable)	7681	3	Pos	Yes	RT-3A-10	RT-3A-H-10	RT-3A-T-10
	7900	6914	6	Neg	Yes	RT-A-10	RT-A-H-10	RT-A-T-10
Ammco HD	5000, 6000, 6002	5677	3	Pos	No	RT-373-10	---	---
Accu-Turn	All combination disc/drum lathes	433796	3	Pos	Yes	RT-AC-10	RT-AC-H-10	RT-AC-T-10
	On-The-Car Lathes	878051	6	Neg	Yes	RT-A-10	RT-A-H-10	RT-A-T-10
All-Tool	747	3331	6	Neg	Yes	RT-A-10	RT-A-H-10	RT-A-T-10
Bean	B-401, B-410, B-501, B-601	90487	3	Pos	Yes	RT-FMC-10	RT-FMC-H-10	RT-FMC-T-10
Bear	1410,1466,1467,1468, 1469, 1478	2264,72265,772834	6	Neg	Yes	RT-B-10	---	---
	10-1430, 10-1435	W136	6	Neg	No	RT-HF-10	---	---
FMC	600, 601, 700, 701, RotoTruer	90487	3	Pos	Yes	RT-FMC-10	RT-FMC-H-10	RT-FMC-T-10
	505, On-The-Car Lathe	91212	3	Pos	Yes	RT-KW-10	RT-KW-H-10	RT-KW-T-10
Hoffman	660	3331	6	Neg	Yes	RT-A-10	RT-A-H-10	RT-A-T-10
Hunter	BL300 On-The-Car Lathe	221580-2	6	Neg	Yes	RT-A-10	RT-A-H-10	RT-A-T-10
	BL-500, BL-501, BL-505	6918	3	Pos	Yes	RT-3AS-10	RT-3AS-H-10	RT-3AS-T-10
	BL-500	221-678-3	3	Pos	Yes	RT-HNT-10	---	---
Kwik-Way	CBL, NCL, SDL Kwik-Lathe OTC Lathe	109-1092-23	3	Pos	Yes	RT-KW-10	RT-KW-H-10	RT-KW-T-10
	Lightening Lathe	109-1092-45	3	Pos	Yes	---	---	RT-KWL-T-10
Performance	6600,7200,7100, 7600	3331	6	Neg	Yes	RT-A-10	RT-A-H-10	RT-A-T-10
Pro-Cut	On-The-Car Lathe	50-701, 50-742	3	Pos	Yes	RT-VBG-10	RT-VBG-H-10	RT-VBG-T-10
RJ West	Perfect 400, 1115HD	W139	3	Pos	Yes	RT-AC-10	RT-AC-H-10	RT-AC-T-10
RTI	BRC35 On-The-Car Lathe	91212	3	Pos	Yes	RT-3A-10	RT-3A-H-10	RT-3A-T-10
Snap-On	YA282,YA277,YA278, YA180 OTC Lathe	109-1092-23	3	Pos	Yes	RT-KW-10	RT-KW-H-10	RT-KW-T-10
Van Norman and Rels	204, 204D, 205, 205DC, 415, 243XV	29687	3	Pos	No	RT-VN-10	RT-VN-H-10	RT-VN-T-10
	Smaller (1/4") radius	---	3	Pos	No	RT-VNS-10	---	---
	204, 304, 405	29005	6	Neg	No	RT-VNA-10	---	---
	303,304,305,404,405,V22	304-7167	2	Pos	No	RT-VNP-L-10	---	---
	204,205,205DR,300,302,333,243,243XV	302-7167	2	Pos	No	RT-VNP-R-10	---	RT-VNP-RT-10
Rels 2000 rotor	45016, 45021	3	Pos	Yes	RT-RL-10	---	---	
VBG	On-The-Car Lathe	50-701	3	Pos	Yes	RT-VBG-10	RT-VBG-H-10	RT-VBG-T-10
Round Tips With Hole		RT-312,RT-312T	360°	Pos	Yes	RT-312	---	RT-312T
Round Solid	Fits RJH and CT Holders	CT10	360°	Pos	No	RT-360-10	---	---

NOTE: The table above shows the original equipment cutting tips for Ammco machines. Most of them use negative-rake tool systems. However, some Ammco machines (especially the 4000 and 7000-series) have been modified in the field by using the TAM-25968 and TAM-25969 positive-rake tool holders (see next page).

If your machine is shown above to have 6-edge tips but has 3-edge tips, it has been modified - please order our RT-3A or RT-3AS series tips.

RT-A	RT-3A	RT-AC	RT-HNT	RT-VN	RT-B	RT-VNA	Cutting Tip Measurements									
Height: .350"	Height: .343"	Height: .445"	Height: .312"	Height: .545"	Height: .343"	Height: .535"										
Thick: .095"	Thick: .093"	Thick: .131"	Thick: .103"	Thick: .125"	Thick: .105"	Thick: .188"										
Hole: .135"	Hole: .133"	Hole: .145"	Hole: .127"	Hole: N/A	Hole: .130"	Hole: .148"										
Rake: NEG	Rake: POS	Rake: POS	Rake: POS	Rake: POS	Rake: NEG	Rake: NEG	RT-3AS	RT-373	RT-KW	RT-VBG	RT-FMC	RT-VNS	RT-RL	RT-VNP-L / -R	RT-360	RT-312
Height: .357"	Height: .625"	Height: .358"	Height: .344"	Height: .452"	Height: .547"	Height: .421"	Height: .902"	Diameter: .311"	Diameter: .311"	Height: .357"	Height: .452"	Height: .547"	Height: .421"	Height: .902"	Diameter: .311"	Diameter: .311"
Thick: .104"	Thick: .125"	Thick: .101"	Thick: .098"	Thick: .125"	Thick: .121"	Thick: .130"	Thick: .100"	Thick: .100"	Thick: .100"	Thick: .104"	Thick: .125"	Thick: .121"	Thick: .130"	Thick: .100"	Thick: .100"	Thick: .100"
Hole: .127"	Hole: .117"	Hole: .125"	Hole: .124"	Hole: .090"	Hole: N/A	Hole: .147"	Hole: N/A	Hole: N/A	Hole: .150"	Hole: .127"	Hole: .117"	Hole: .125"	Hole: .124"	Hole: .090"	Hole: N/A	Hole: .150"
Rake: POS	Rake: POS	Rake: POS	Rake: POS	Rake: POS	Rake: POS	Rake: POS	Rake: POS	Rake: POS	Rake: POS	Rake: POS	Rake: POS	Rake: POS	Rake: POS	Rake: POS	Rake: POS	Rake: POS

CYLINDER HEAD REBUILDING
 ASSEMBLY & SAFETY
 CLEANING, REBUILDING
 SHORT BLOCK REBUILDING
 FLYWHEEL GRINDING
 CRANKSHAFT/ TOOLS & SUPPLIES
 MISCELLANEOUS
 BRAKE SERVICE TOOLING
 MEASURING TOOLS
 V-TWIN & METRIC HARD PARTS

... another
satisfied
customer

"Goodson is the most hassle-free vendor that I deal with. Everything I have ordered has always been in stock."

- Jerry Darien, Darien Racing, Goodson customer since 2012

CYLINDER HEAD
REBUILDING



Tip Holder for Drums

Fits **Ammco** 1000, 2002, 3000, 4000, 4100, 7500 & 7700; **All Tool** 747; **Hoffman** 660; **Performance** 6600, 7200, 7100 & 7600
Dimensions: $\frac{1}{2}$ " x $\frac{3}{8}$ " x $2\frac{1}{4}$ "
Replaces OE No. 9872
Orientation: Right
Use Tips: RT-A Series (includes 1)
Order No. **TAM-41R**

CLEANING,
ASSEMBLY & SAFETY



Tip Holder for Rotors

Fits **Ammco** 3000, 3850, 4000, 4100, 7000 & 6900, 6950 Twin Cutters; **All Tool** 747; **Performance** 6600, 7200, 7100, 7600; **Hoffman** 660
Dimensions: $\frac{3}{8}$ " x $\frac{3}{8}$ " x $1\frac{1}{8}$ "
Replaces OE No. 10701, 10702
Use Tips: RT-A Series (includes 1)
Left: Order No. **TAM-702**
Right: Order No. **TAM-701**

SHORT BLOCK
REBUILDING



Tip Holder for Rotors

Fits **Ammco** 3000, 3850, 4000, 4100, 7000 & 6900, 6950 Twin Cutters
Dimensions: $\frac{3}{8}$ " x $\frac{3}{8}$ " x $1\frac{1}{8}$ "
Replaces OE No. 25968, 25969
Use Tips: RT-3A or RT-3AS (includes 1)
Left: Order No. **TAM-25969**
Right: Order No. **TAM-25968**

CRANKSHAFT/
FLYWHEEL GRINDING



Tip Holder for Drums & Rotors

Fits **Kwik-Way** CBL, NCL, SDL;
Snap-On Y282, Y277, Y278, 180
Dimensions: $\frac{3}{8}$ " x $\frac{3}{8}$ " x $2\frac{1}{2}$ "
Replaces OE No. 109-1091-02,
109-1091-00
Use Tips: RT-KW Series (includes 1)
Left: Order No. **TKW-85L**
Right: Order No. **TKW-84R**

MISCELLANEOUS
TOOLS & SUPPLIES

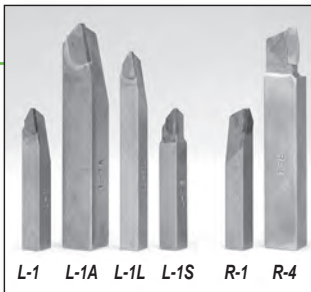

Brazed Carbide Brake Lathe Tools

• Fit most popular brake drum lathes

BRAKE SERVICE
TOOLING

Left Hand Cutting Tools

Size	Application	Order No.
$\frac{3}{8}$ " sq. x $2\frac{1}{2}$ "	Replaces Bean 43-46L; Bear 23211; Star CB-8; VN 302-7272 for 303, 304, 304H	L-1
$\frac{5}{8}$ " sq. x 4"	Replaces Ammco 5725, for 5000; Star CB-30; VN "Big Brute" for 310-404 Hardspots	L-1A
$\frac{3}{8}$ " sq. x $3\frac{1}{2}$ "	Extra long L-1 for small dia. drums	L-1L
$\frac{3}{8}$ " sq. x $2\frac{1}{2}$ "	Master carbide-tipped with 7° rake angle	L-1S

Right Hand Cutting Tools

Size	Application	Order No.
$\frac{3}{8}$ " sq. x $2\frac{1}{2}$ "	Replaces Bean 43-46R; Bear 20718; Star LB-16; VN 302-7171 for 204, 300, 302, 302H, 333, 243XV; and Barrett & Lemppo	R-1
$\frac{3}{8}$ " sq. x $2\frac{1}{2}$ "	Master carbide-tipped with 7° rake angle	R-1S
$\frac{5}{8}$ " sq. x 4"	Replaces Bear 24034, Star CB-35	R-4

Hardspot Cutters

Left Hand

Size	Use	Order No.
$\frac{3}{8}$ " x $\frac{1}{2}$ " x $2\frac{3}{8}$ "	Drums	L-5

Right Hand

Size	Use	Order No.
$\frac{3}{8}$ " x $\frac{1}{2}$ " x $2\frac{3}{8}$ "	Drums	R-5



L-5 R-5

MEASURING
TOOLS

V-TWIN & METRIC
HARD PARTS

Don't buy a new
brake lathe ...
expand your existing
one to handle rotors
up to 15"



Lead Screw Bushing

- Easy installation
- Increases lathe capacity to 15"
- Ideal for machining large rotors common on SUVs and large pick-ups
- Fits Ammco 3000 and 4000 Brake Lathes
- Order No. **LSB-78529**

Brake Shoe Grinding Sleeves

- Aluminum-Oxide abrasive



ID	Length	Grit	Order No.
3"	5 $\frac{1}{4}$ "	40	AS-2
3"	6 $\frac{1}{8}$ "	40	AS-4

Carbide Tipped Brake Drum Swedge Cutting Tool

- Hard-to-find tool cuts wheel stud swedges to remove and replace pressed-in wheel studs
- Use with a drill press or mill
- For 1/2" stud
- Order No. **ST-500**



Brake Lathe Silencers



34" Neoprene Brake Lathe Silencer

- Longer lasting than rubber
- Neoprene material resists deterioration associated with standard rubber belts
- 7 sound deadening weights
- Measures: 34" L x $\frac{5}{8}$ " W x $\frac{3}{16}$ " Thick
- Order No. **GT-6030N**



34" Rubber Brake Lathe Silencer

- Live rubber strap with 7 sound deadening weights
- For vented rotors
- Measures: 34"L x $\frac{5}{8}$ "W x $\frac{3}{16}$ " thick
- Order No. **CE-8**

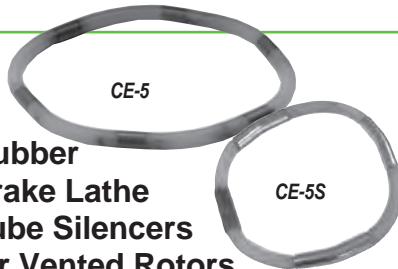

Rubber Brake Lathe Tube Silencers for Vented Rotors

- $\frac{9}{16}$ " OD rubber tube with internal sound dampeners
- 2 sizes to choose from

Diameter	Weights	Order No.
9"	6	CE-5
8"	4	CE-5S



Magnetic Strap Brake Lathe Silencer for Non-Vented Rotors

- Measures 48"L x 1/4" wide
- Eliminates silencer wandering on solid, non-vented rotors
- Order No. **CE-10**



Spring Silencer For Vented Rotors

- For 6" to 9" rotors
- Metal spring with internal sound dampeners
- Order No. **CE-13**

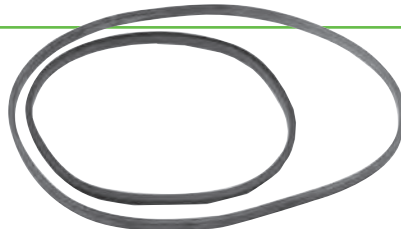

Rubber Band Brake Lathe Silencers for Non-Vented Rotors

- Neoprene rubber gasket type bands for thin solid rotors
- Both sizes are $\frac{5}{16}$ " wide x $\frac{3}{16}$ " thick

Length	Order No.
6 $\frac{1}{2}$ "	CE-11
9 $\frac{1}{4}$ "	CE-12



Replacement Pucks for Ammco Friction Rotor Silencer

- Heavy non-asbestos pucks provide the mass needed to dampen vibration
- Sold as a pair
- Fits Ammco 7075 silencer
- Order No. **CE-9**



Clamp-On Brake Lathe Silencers For Vented & Non-Vented Rotors

- Follows the cut to absorb vibrations where they start
- Outlast plastic pads, rubber straps and bands

Application	Order No.
For Bench Model Brake Lathes	CE-6
For On-The-Car Brake Lathes	CE-26



Premium Rubber Brake Lathe Silencers for Brake Drums

- Premium live rubber straps
- Two sizes to choose from

Application	Size	Order No.
Passenger Cars	62"L x 2 $\frac{7}{8}$ "W x $\frac{1}{8}$ " Thick	CE-1
Trucks	78"L x 2 $\frac{7}{8}$ "W x $\frac{1}{8}$ " Thick	CE-2

CYLINDER HEAD REBUILDING
 ASSEMBLY & SAFETY
 CLEANING,
 SHORT BLOCK REBUILDING
 FLYWHEEL GRINDING
 CRANKSHAFT/
 MISCELLANEOUS TOOLS & SUPPLIES
 BRAKE SERVICE TOOLING
 MEASURING TOOLS
 V-TWIN & METRIC HARD PARTS



Replacement Work Light

- 30" adjustable arm
- 5/8" round mounting end
- Uses up to 100W standard base bulb (not included)
- Easily accessible switch
- Fits most Ammco models
- Order No. **GT-7963**

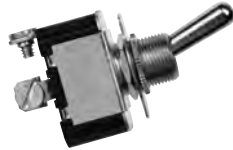

Replacement Switch for Ammco Brake Lathes

- Easy to install
- Fits most models
- Order No. **GT-7893**



1HP Motor for Ammco Brake Lathes

- ### 1" Arbor for Ammco
- Fits Ammco 2002, 3000, 4000, 4100, 7000, 7500 & 7700 models
 - 7/8" x 9 LH thread
 - Precision ground
 - Factory checked for run-out of less than .001" • Heat treated, stress relieved tool steel • For drums & rotors up to 125 lbs.
 - Order No. **GT-3101**

- Fits 3000, 4000, 4100, 7000, 7500 & 7700 models
- 208 / 230 / 115V • 60Hz
- 1725 RPM • Shaft: .625"
- Includes motor plate and fasteners
- Order No. **GT-2165**

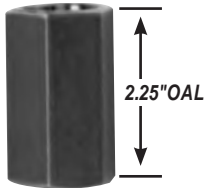

1" Arbor Nut For Ammco

- 7/8" x 9 LH thread
- Fits Ammco 2002, 3000, 4000, 4100, 7000, 7700 and 3850 models
- Order No. **GT-3102**



1" Arbor Nut For All But Ammco

- 1" x 9 LH thread
- Fits AccuTurn 433701, All Tool 747, FMC 601, 701 & 702, Hunter, Van Norman/Rels 204, 243
- Order No. **GT-20442N**



Brake Lathe Centering Spring

- Fits any 1" arbor brake lathe
- 1.687" ID
- 1.927" OD
- 4.000" OAL
- Order No. **GT-3110**



Mounting Spacers

- Fit all 1" arbor brake lathes

Length	Order No.
1/2"	GT-3125
Flexible	GT-9492



enlarged to show detail

Brass Wear Inserts For Ammco

- Sold individually
- | Dia. x Lgth. | Order No. |
|----------------|----------------|
| 3/16" x 1/8" | GT-3141 |
| 1/16" x 1/4" | GT-3142 |
| (most popular) | |
| 1/4" x 1/16" | GT-9836 |



Replacement Feed Screw Seal For Ammco

- 1 1/4" OD
- Order No. **3163**



Replacement Screw for Twin Cutter Tool Bit Holders

- Square Head Screw
- Order No. **GT-9249**

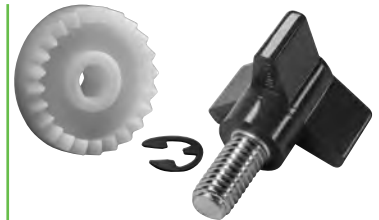

Small Ammco Replacement Parts

Description	Order No.
Locking Knob	6854
Cross Feed Shear Gear with C-Clip	7996



Ammco Rotor & Drum Feed Screw Bushings

Description	Order No.
Rotor Feed Bushing (early)	GT-10868
Rotor Feed Bushing (late)	GT-10868X
Drum Feed Bushing (all)	GT-4670
Lead Screw Bushing Adaptor	LSB-78529



GT-4670



GT-11227

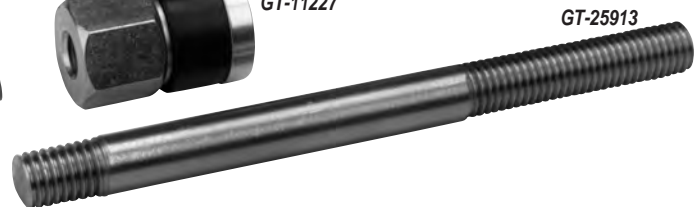

GT-25913

Tooling Hold Down Pieces For Ammco

Description	Order No.	Incl.
Stud Assembly	GT-25900	▼
6 1/2" Stud	GT-25913	x
Nut Assembly (must be used with 6 1/2" Stud)	GT-11227	x



Pastelub™ Synthetic High Temp Brake Lubricant

- OE recommended • High pressure resistant
- Recommended for the backs of brake pads
- Not for use on friction surfaces
- 2400°F Ultra high-temperatures range
- Patented "real synthetic" Swiss formula won't melt, rub or wash off brake parts • Gray • Net wt. 7 oz.
- No silicone or petroleum to weaken the carrier base
- Order No. **BPL-2400**



Ceramlub-2800™ Extreme High Temperature Lubricant

- Use on brake caliper slides, etc.
- Contains ceramic pressure solids and high concentrations of anti-corrosive agents
- Specifically designed for use on caliper slides, rubber seals & O-Rings
- A great complement to Pastelub™ Hi-Temp Lubricant
- Purple • Net wt. 7 oz.
- Order No. **CBL-2800**

CYLINDER HEAD REBUILDING
CLEANING, ASSEMBLY & SAFETY
SHORT BLOCK REBUILDING
FLYWHEELS
CRANKSHAFT/ROD REBUILDING
MISCELLANEOUS TOOLS & SUPPLIES

BRAKE SERVICE TOOLS

MEASURING TOOLS

V-TWIN & METRIC HARD PARTS

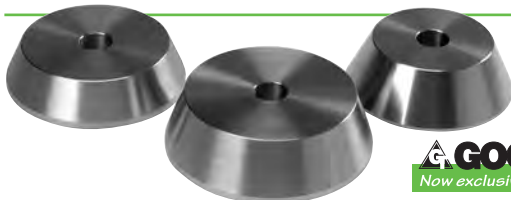

GOODTOOL
Now exclusively from Goodson

Heavy Duty Brake Lathe Centering Cones

- For brake lathes with 1" dia. arbors

Large Dia.: 5.125"	Large Dia.: 5.500"	Large Dia.: 6.125"
Small Dia.: 3.750"	Small Dia.: 4.500"	Small Dia.: 5.000"
Order No.: GT-5053	Order No.: GT-5052	Order No.: GT-5054

When using bell clamps and centering cones always be sure they are clean and free of any dirt or rust. Keep a light coating of oil on them to prevent rusting.

Never use a cone or a bell clamp for anything other than mounting a brake rotor or drum onto the brake lathe. Always use the largest bell clamp that will fit the rotor or drum for the best support.



Automotive Brake Lathe Bell Clamps

- For brake lathes with 1" dia. arbors

OD Size: 4.500"	OD Size: 5.700"
Arbor Size: 1.000"	Arbor Size: 1.000"
Order No.: GT-9490	Order No.: GT-3123

Heavy Duty Brake Lathe Bell Clamps

- For brake lathes with 1" dia. arbors

OD Size: 6.500"	OD Size: 7.750"
Arbor Size: 1.000"	Arbor Size: 1.000"
Order No.: GT-5055	Order No.: GT-5056

Heavy Duty Brake Lathe Spring

- Use to exert extra pressure
- Measures 2.515"OD x 2.217" ID x 4"L
- Order No. **GT-5059**



Drive Pulleys & Belts for Ammco

- Fit Ammco 3000, 4000, 4100, 7000 & 7100
- Serpentine design runs quieter and increases arbor speed by 175RPMs • Virtually eliminates vibration



New-Style (Serpentine)

Description	Order No.
Pulley Set (Includes 20¼" belt & 2 pulleys)	GT-5001
20¼" Belt	GT-5002
19" Belt	GT-5003

Original-Style (V-belt) Replacements

Description	Order No.
25" Belt (replaces OE 3161)	GT-3161
24" Belt (replaces OE 10241)	GT-10241

tech tips from the techxperts™ Install the drive pulley with the pin toward the right angle drive. The roll-pins drive against each other. A nylon sleeve prevents metal to metal contact.

Don't buy a new brake lathe ... expand your existing one to handle rotors up to 15"

Lead Screw Bushing

- Easy installation
- Increases lathe capacity to 15"
- Ideal for machining large rotors common on SUVs and large pick-ups
- Fits Ammco 3000 and 4000 Brake Lathes
- Order No. **LSB-78529**





"We pride ourselves on packaging our products carefully and professionally. We want you to receive your order quickly and in good condition."

- Brian, Goodson Receiving, 34 years of service

CYLINDER HEAD REBUILDING
CLEANING, ASSEMBLY & SAFETY
SHORT BLOCK REBUILDING
CRANKSHAFT/ FLYWHEEL GRINDING
MISCELLANEOUS TOOLS & SUPPLIES
BRAKE SERVICE TOOLING
MEASURING TOOLS
V-TWIN & METRIC HARD PARTS

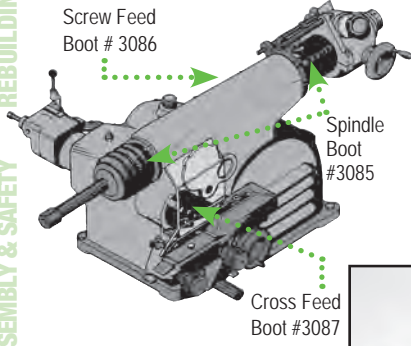

GOODTOOL
Now exclusively from Goodson



Replacement Boot Packs

- Keep extra boots on hand for routine maintenance or emergency replacement
- Fits Ammco 3000, 4000, 4100, 7000, 7700

Description	Order No.
Polyethylene Spindle Boot	3085
Screw Feed Dust Boot	3086
Cross Feed Dust Boot	3087
Boot Ring	23682
C-Clip	SBR-4435
Snap Ring	SBR-3159

tech tips
from the techxperts™



Get step by step instructions on replacing brake lathe boots

Check out the blog post (with pictures) on our website. Use your smart phone or other smart device to scan the code at left for instant access to the post.

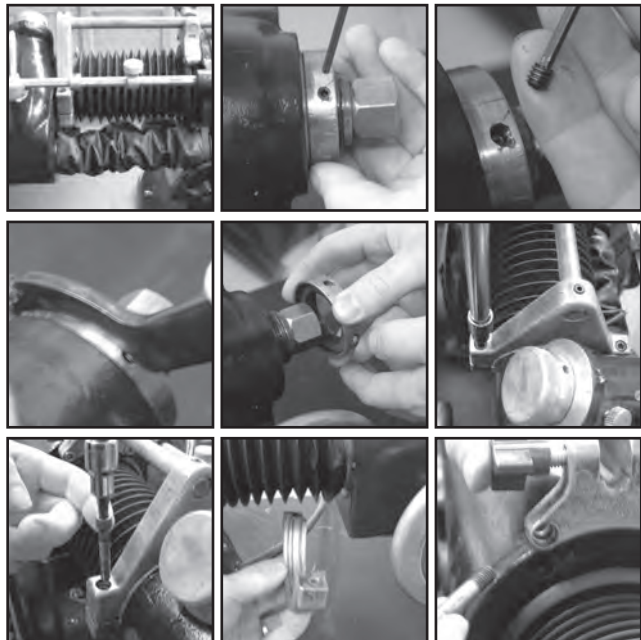

See page 83 for more Flex-Hones®

Brake Rotor Flex-Hones®

- Provide a non-directional finish
- Use with a 3/8" variable speed drill at 600-1000 RPM
- Zirconium abrasive
- Use dry

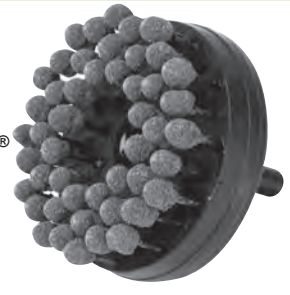

Type	Grit	Order No.
Fine	240	BRF-25F
Medium	120	BRF-25M
Coarse	60	BRF-25C

Order 3 or more Flex-Hones® (any combination) to Save 10% off Jobber!

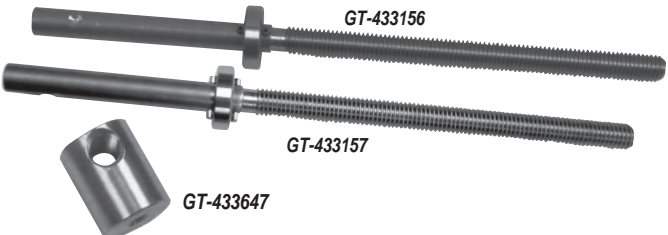

Assorted Accu-Turn Replacement Parts

Description	Order No.
Rotor Feed Screw Assembly (1/2" 20TPI)	GT-433156
Drum Feed Screw Assembly (1/2" 13TPI)	GT-433157
Rotor Feed Bushing (fine thread)	GT-433647
Drum Feed Bushing (not shown) (coarse thread)	GT-433646

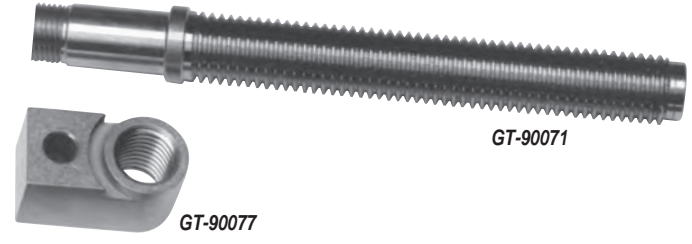

Rotor Feed Screws & Nuts For FMC & Bean

Description	Order No.
Rotor Feed Screw	GT-90071
Rotor Feed Nut	GT-90077



Brake Drum Grinding Wheels

- Aluminum-Oxide abrasive
- For Van Norman / Rels 204, 300, 302, 303, 333 & 404 Drum Grinders
- Size: 3" x 1/2" x 1"
- OE No.: 8522
- Shape: Recessed
- Order No. GDV-304



Precision Straight Edges

- 2 sizes to choose from
- Accuracy .005" per foot
- Precision ground one edge
- .375" thick high quality heat-treated steel construction
- Each straight edge is pre-drilled for easy wall storage

Description	Order No.
24" straightedge, 1 precision edge	DIS-24
36" straightedge, 1 precision edge	DIS-36



Rod Bolt Stretch Gauge

- Accurate to .001"
- Features a 1½" dial gauge
- Extra heavy-duty tension spring for repeatable accuracy
- For bolts from 1" to 2½" long

Description	Order No.
Rod Bolt Stretch Gauge	RBSG-3
Optional Contact Point	ERBG-3T
Replacement Pointer	RBSG-P

tech tips
from the techxperts™

Most engine rod failures aren't from faulty parts, they're from improper installation. When you're installing connecting rods, you need to

check the rod bolt stretch by performing a series of torquing and loosening and recording the readings.

Here's how:

1. Torque the bolts to 15 foot pounds and measure the stretch. Record the reading, then loosen the bolts.
2. Repeat at 15 foot pounds and record the reading.
3. Repeat, increasing to 30 foot pounds, record the reading.
4. Repeat, increasing to 60 foot pounds, record the reading.
5. Repeat at 60 foot pounds and record the reading.

Each time you loosen the bolts, measure to be sure that the rod bolts have returned to within .001" of the starting size. If you have a greater variation, get rid of the rod bolts and start with new ones.

When you're conducting final assembly, be sure you use the stretch specified by your rod manufacturer. Attach a rod bolt stretch gauge to the connecting rod bolt and zero it. Use an extra-long box wrench to tighten until the proper stretch is achieved.

Small Hole Gauge Set

- See if rebuilding or replacing is needed by checking guide wear
- Check guide bosses for proper interference fit during replacement
- Check and maintain correct stem-to-guide ID clearance
- 4-piece set has combined range of .125" to .500"
- Order No. **SHG-4**

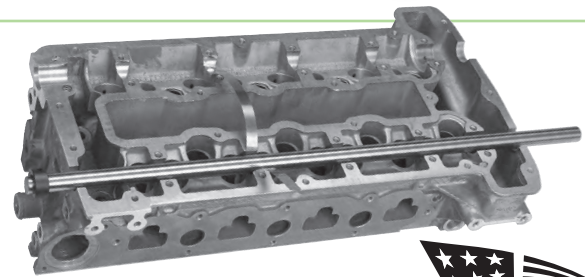
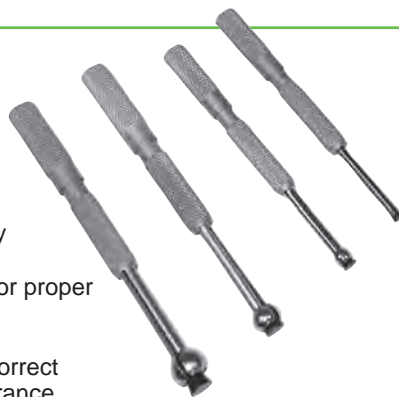

26" Round Warp Gauge

- Use with feeler gauges (below)
- ¾" diameter tool steel
- Includes anti-roll collar and eye bolt allowing you to hang it for safe, convenient storage
- Order No. **EWG-100**



12" Feeler Gauges

- Measure piston-to-wall clearance when honing, to find ring end gap and to check cylinder heads with a straight-edge
- Also useful for shimming while straightening heads and for machine set-ups

Complete Kit	Order No.	
Thick .0015"	FE-KIT	▼
.0020"	FE-0015	x
.0030"	FE-002	x
.0040"	FE-003	x
.0050"	FE-004	x
.0060"	FE-005	x
.0070"	FE-006	x
.0080"	FE-007	x
.0090"	FE-008	x
.0100"	FE-009	x
.0150"	FE-010	x
.0200"	FE-015	x
	FE-020	x

Mitutoyo

Split Ball Bore Gauge

- Dial gauge with large contact area
- Measures quickly & accurately to .0001"
- Works in threaded or knurled guide IDs
- Range: .280"-.400" • Easy to change contacts
- Order No. **MVG-34**



6 Piece Telescoping Gauge Set

- Compress spring plunger and lock by twisting handle
- Insert into bore and release plunger – it will expand to fit
 - Lock again and remove
 - Measure with a micrometer
 - Double plunger design for consistent measuring
 - Long-lasting finish
 - Size range: ¾" - 6"
- Order No. **MTG-6** Jobber



CYLINDER HEAD REBUILDING
CLEANING, ASSEMBLY & SAFETY
SHORT BLOCK REBUILDING
CRANKSHAFT/ FLYWHEEL GRINDING
MISCELLANEOUS TOOLS & SUPPLIES
BRAKE SERVICE TOOLING
MEASURING TOOLS
V-TWIN & METRIC HARD PARTS

full service
...fast



"From the time we answer the phone to when you receive your delivery, our goal is to get it right the first time and every time."
- Daniela, Goodson Advertising Department, 2 years of service



Build Your Own Valve Guide Gauge Set! Order the Valve Guide Gauge (P-300), Setting Fixture (P-610A) and the Valve Guide Probe you need.



Valve Guide Gauge Set

- The only way to be sure clearance is correct is to gauge it
- Checks all types of guides for size and roundness FAST
- Set up and measure valve guide IDs quickly and easily
- Complete set includes gauge, 3 probes (.312", .344" and .375"), hex wrench, setting fixture and metal storage case with spaces for all components
- Dial calibrated in .0002" increments

Description	Order No.	Incl.
Complete Valve Guide Gauge Set	P-310	▼
Valve Guide Gauge	P-300	x
Setting Fixture	P-610A	x
Valve Guide Probes		
Size	Range in.	mm
.236"	.224" to .264"	5.69 to 6.71
.250"	.238" to .278"	6.05 to 7.05
.281"	.269" to .309"	6.83 to 7.85
.312"	.300" to .340"	7.62 to 8.64
.344"	.332" to .372"	8.43 to 9.45
.375"	.363" to .403"	9.22 to 10.24
.438"	.426" to .466"	10.82 to 11.84

Additional probe sizes available by special order



Sunnen® AG-Series Precision Gauge

- Dial reads directly in "tenths" (.0001")
- Checks rod journal bore for distortion
- Measures size instantly
- Wear-compensated gauge points for permanent accuracy
- Rugged construction – all moving parts are enclosed in the housing
- Includes Point Sets listed below (optional sets are available, call for information)



Description	Order No.
.375" - 3.375" (9.5 - 85.7mm) Range Gauge	AG-300
Standard Point Set (.720" - 1.530" Range)	AG-210
Medium Point Set (1.50" - 2.25" Range)	AG-620
Large Point Set (1.932" - 2.687" Range)	AG-630
Sun-Dura® Gauge Cover (8"L x 8"H x 4"D)	GMC-AG300

Point sets will only fit AG-gauges higher than Serial No. 4000



Distributor Depth Gauge

Working on a Big Block or Small Block Chevy with a distributor? Avoid problem wear and potential failure caused by a distributor that fits too deep. This easy to use gauge measures the depth of engagement allowing you to compensate to create adequate clearance. Kit comes complete with a .500" diameter adaptor. An optional .491" shaft is also available.

Description	Order No.
Distributor Depth Gauge Kit	DDG-05
.491" Shaft	DDG-491

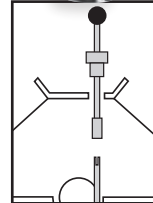

Fig. 1 Insert depth gauge in place of distributor. Bottom out in oil pump drive.

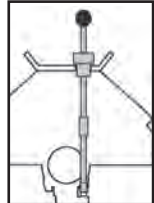

Fig. 2 Push down on the top collar, making contact with manifold.

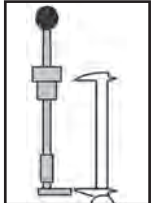

Fig. 3 Remove depth gauge from engine. Install adaptor in distributor tool. Measure and record depth.

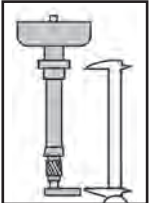

Fig. 4 Install adaptor in distributor drive. Measure as before and compare. Shim as needed to create clearance.

⚠ WARNING: Operating, servicing and maintaining a passenger vehicle or off-road vehicle can expose you to chemicals including engine exhaust, carbon monoxide, phthalates, and lead, which are known to the State of California to cause cancer and birth defects or other reproductive harm. To minimize exposure, avoid breathing exhaust, do not idle the engine except as necessary, service your vehicle in a well-ventilated area and wear gloves or wash your hands frequently when servicing your vehicle. For more information go to www.P65Warnings.ca.gov/products/passenger-vehicle.

CYLINDER HEAD REBUILDING
CLEANING, ASSEMBLY & SAFETY
SHORT BLOCK REBUILDING
CRANKSHAFT/ FLYWHEEL GRINDING
MISCELLANEOUS TOOLS & SUPPLIES
BRAKE SERVICE TOOLING
MEASURING TOOLS
V-TWIN & METRIC HARD PARTS

Sunnen® Dial Bore Gauges

Sunnen® Dial Bore Gauges



- Standard Sunnen® Dial Bore Gauges read out in tenths
- Also available in five-tenths and metric (special order)
- Diameter ranges from .495" to 6.000" (see chart for gauge ranges)
- All models below feature all-carbide gauging points, wear-proof ball crank and adjustable centralizers
- Includes molded storage case with all tools and wrenches required for setup and adjustment

Shock-Shield protects dial from hand heat and jarring to assure accurate reliable readings.

All standard Sunnen Dial Bore Gauges are TENTH READING. Metric and .0005" readouts are also available (special order). Dial can be indexed 90° for easy reading at any angle.

Adjustable centralizers for proper centering over the entire diameter range. One twist adjusts gauge tension so head goes into and out of any size hole smoothly.

Patented wear-proof ball crank assures repeatability over a long life.

Carbide indicating points are long wearing and replaceable.

Transfer Rod

Indexable Centralizer Points

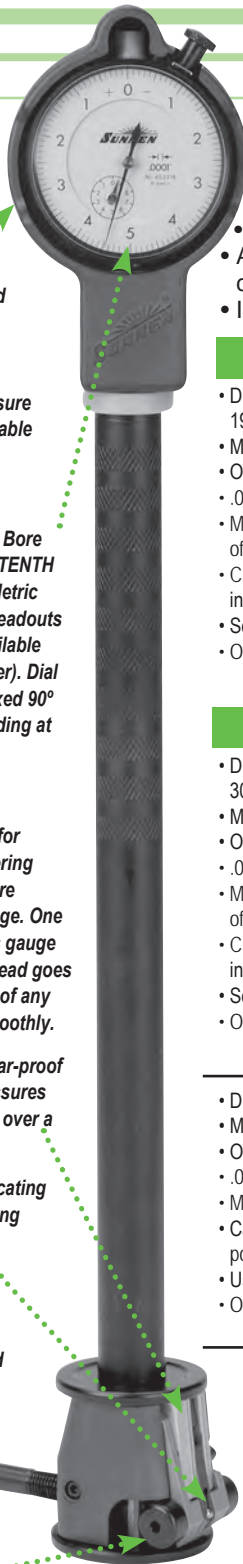

Non-Retractable Dial Bore Gauges

- Dia. Range: .495" to .750" (12.6 to 19.0mm)
- Max. Gauging Depth: 7.00" (175mm)
- Overall Length: 11.8125" (302mm)
- .0001" Reading
- Measures to within .200" of the bottom of a blind bore
- Carbide balls replaceable in the indicating fingers only
- Set with SCF-502 Setting Fixture
- Order No. **GA-4141**

- Dia. Range: 2.00" to 6.00" (50 to 150mm)
- Max. Gauging Depth: 12.00" (300mm)
- Overall Length: 17.00" (432mm)
- .0001" Reading
- Measures to within .500" of the bottom of a blind bore
- Carbide balls replaceable in indicating fingers and extension points
- Use CF-1126 Setting Fixture
- Order No. **GA-2121**

- Dia. Range: 2.00" to 6.00" (50 to 150mm)
- Max. Gauging Depth: 12.00" (300mm)
- Overall Length: 17.00" (432mm)
- .0005" Reading
- Measures to within .500" of the bottom of a blind bore
- Carbide balls replaceable in indicating fingers and extension points
- Use CF-1126 Setting Fixture
- Order No. **GA-2125**

Retractable Dial Bore Gauges

- Dia. Range: .740" to 1.19" (18.9 to 30.20mm)
- Max. Gauging Depth: 12.00" (300mm)
- Overall Length: 17.6875" (451mm)
- .0001" Reading
- Measures to within .270" of the bottom of a blind bore
- Carbide balls replaceable in the indicating fingers only
- Set with SCF-502 Setting Fixture
- Order No. **GR-6241**

- Dia. Range: 1.18" to 2.00" (30.0 to 50.8mm)
- Max. Gauging Depth: 12.00" (300mm)
- Overall Length: 17.75" (452mm)
- .0001" Reading
- Measures to within .335" of the bottom of a blind bore
- Carbide balls replaceable in indicating fingers and extension points
- Set with SCF-502 Setting Fixture
- Order No. **GR-9241**

- Dia. Range: 2.00" to 6.00" (50 to 150mm)
- Max. Gauging Depth: 12.00" (300mm)
- Overall Length: 17.00" (432mm)
- .0001" Reading
- Measures to within .500" of the bottom of a blind bore
- Carbide balls replaceable in indicating fingers and extension points
- Use CF-1126 Setting Fixture
- Order No. **GR-2121**

- Dia. Range: 2.00" to 6.00" (50 to 150mm)
- Max. Gauging Depth: 24.00" (600mm)
- Overall Length: 29.00" (737mm)
- .0001" Reading
- Measures to within .500" of the bottom of a blind bore
- Carbide balls replaceable in indicating fingers and extension points
- Use CF-1126 Setting Fixture
- Order No. **GR-2241**

- Dia. Range: 2.00" to 6.00" (50 to 150mm)
- Max. Gauging Depth: 24.00" (600mm)
- Overall Length: 29.00" (737mm)
- .0005" Reading
- Measures to within .500" of the bottom of a blind bore
- Carbide balls replaceable in indicating fingers and extension points
- Use CF-1126 Setting Fixture
- Order No. **GR-2245**

Dial Bore Gauge Setting Fixtures

- Models combine to cover a continuous range of .054" to 8" in .0001" increments
- Heavy stress-relieved cast iron bases
- Lapped carbide micrometer anvils
- Built-in magnifier
- Each setting fixture includes a master calibrating ring
- Size Setting Adaptor centers gauge probes between parallel reference surfaces on SCF-502 Setting Fixture

SCF-502 shown with GR-6241

CF-1126 shown with GR-2121

SCF-502 with CF-540 Size Setting Adaptor shown with GR-3000 Gauge

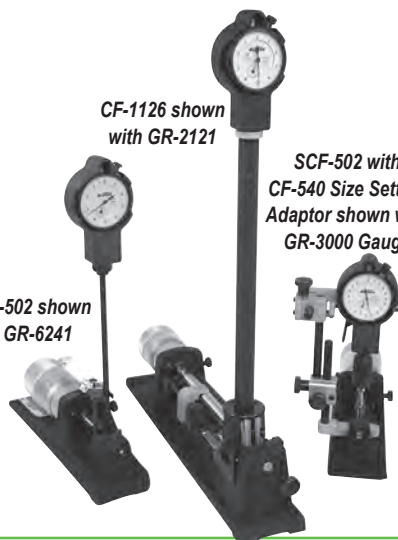

Range	Order No.
.054" to 2.00"	SCF-502
2.00" to 8.00"	CF-1126
Size Setting Adaptor	CF-540

Gauges & Setting Fixtures Sold Separately



CYLINDER HEAD REBUILDING
 ASSEMBLY & SAFETY
 CLEANING
 SHORT BLOCK REBUILDING
 FLYWHEEL GRINDING
 CRANKSHAFT/ MISCELLANEOUS
 TOOLS & SUPPLIES
 BRAKE SERVICE
 MEASURING TOOLS
 V-TWIN & METRIC HARD PARTS



Mitutoyo

Dial Bore Gauge Set

- Rugged bore gauge with protected dial
- Carbide tipped contact points
- .0001" (.001mm) graduations • Indication stability: .00008"
- Accuracy: .0002" • Shoe can be rotated for a fresh wear surface • Sets up with a standard micrometer (see page 128)

Range	Description	Order No.
2.0"-6.0"	11 anvils and 4 spacers	MMCB-06
Replacement Spacers for anvils 2" & larger	.020"	MMCB-06-020
	.040"	MMCB-06-040
	.080"	MMCB-06-080
	.120"	MMCB-06-120
Replacement Lens		MMCB-06LENS
Replacement Dial Indicator		MMCB-06IND
Replacement Dial Cover		MMCB-06COVER



0.0005" Graduation Dial Bore Gauge

- Includes: .050" travel indicator, 3 spacers (.100", .050" and .020"), 11 anvils and storage case
- Use for precise bore measurements
- Bore depth: 6" • Range: 2" to 6"

Description	Order No.
Dial Bore Gauge	EBG-265
11 Piece Replacement Spacer Set	EBG-ANVILS



Metric Dial Bore Gauge

- Carbide anvils
- Easy-to-read gauge
- Insulated grip with chrome plated handle
- Includes: extension holder and fitted case
- Range: 35 to 160mm
- Graduations: 0.01mm
- Order No. **MCBG-160**



0.7" to 1.5" Range Cylinder Dial Bore Gauge Set

- Carbide anvils • Easy to read gauge
- Measure cylinders up to 9.5" deep
- Graduations: 0.0005" • Self-centering • Insulated grip
- Chrome plated handle • Includes extension holder and case • Order No. **FBG-7**



Internal Electronic Caliper

- Ideal for measuring mating port runners and bowl diameters
- Hardened contact surfaces
- Robust housing with large LCD display
- Range: 0.5" to 6.0" • Reading: .01" (.3mm)
- Spring loaded locking nut
- Order No. **IEC-56**



1.4" to 6" Range Cylinder Dial Bore Gauge Set

- Carbide anvils • Easy to read gauge
- Measure cylinders up to 9.5" deep • Graduations: 0.0005"
- Self-centering • Insulated grip • Chrome plated handle
- Includes extension holder and case
- Order No. **FBG-146**

Mounts on Your Pilot



Valve Seat Height Gauge

Includes Dial Indicator

- Confirm seat height to fire deck location
- Adjusts for all popular seat diameters
- Accurate to .001"
- Seat contact probe aligns on valve seat while gauge rides along the fire deck
- Pilot aligns in valve guide (pilot sold separately)
- Adjustable to fit popular seat diameters from .750" to 3.00"

Description	Fits Pilot	Order No.
Valve Seat Height Gauge Kit	.375"	VSHG-375
Replacement Dial Indicator		EDI-1

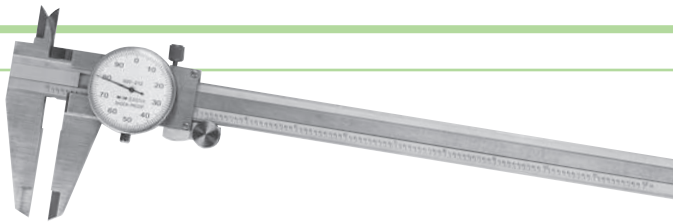

12" Direct Reading Dial Caliper

- .001" single revolution • Hardened measuring face
- Precision Ground • Micro-lapped for accuracy
- Adjusting slide for fine adjustment
- Take inside, outside and depth measurements
- Satin Chrome finish with engraved graduations
- Clamp for repetitive readings • Accurate to .001" per 6"
- Covered Rack • Deluxe fitted case
- Order No. **EDC-12**

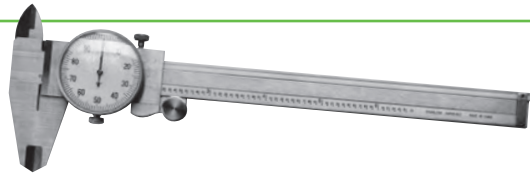

6" Direct Reading Dial Caliper

- Four way measurement - outside, inside, depth and step
- Hardened stainless steel with satin chrome finish
- Precision ground and lapped measuring surfaces
- Reads direct to .001" or with .100" graduations on beam
- Adjustable bezel with lock • Thumb roll with lock
- 1 1/8" jaw length • Large easy to read dial
- Covered rack • Deluxe fitted case
- Order No. **MDC-03**



6" Digital Caliper

- Accuracy: .0008" under 4" length / .0012" over 4" length
- .0005" (.01mm) resolution • Automatic floating zero
- Used to take inside and outside measurements
- Direct inch/metric conversion
- Large, high-contrast LCD display
- On/Off Button • Deluxe fitted case

Description	Order No.
Digital Caliper	EEDC-06
Replacement Battery	EDC-06B

Use with a one or more dial indicators

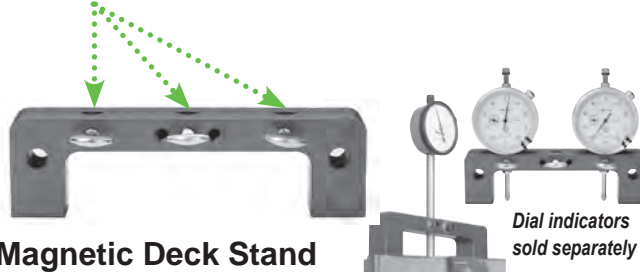

Magnetic Deck Stand

- Precision manufactured with 6 to 8 pounds of magnetic pull yet slides smoothly over the piston dome and deck
- Should only be used with dial indicators (sold separately) in upright position - perpendicular to the ground
- Order No. **MDBS-2**

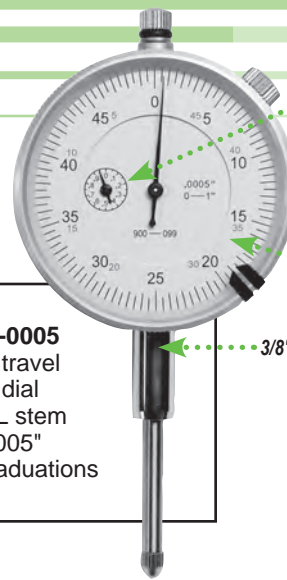

Revolution Counter
(included on most models)

Adjustable bezel
for zero settings

Shatter resistant crystal

- EDI-0005**
- 1" travel
 - 2" dial
 - 1"L stem
 - .0005" graduations

3/8" stem

All indicators
have lug back



- EDI-1**
- 1" travel • 2" dial
 - 1"L stem
 - .001" graduations



- MDI-2**
- 2" travel • 3" dial
 - 2"L stem
 - .001" graduations



- MDI-12**
- .125" travel
 - 2" dial
 - 12"L stem
 - .001" graduations



Starrett
Goodson
EXCLUSIVE

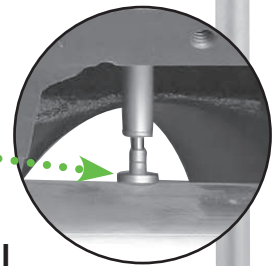

Dial Indicator Flat Anvil

- Use with dial indicator (sold separately) to make full contact on surface to be measured
- Especially useful when measuring deep inside blocks in combination with our magnetic deck stand (MDBS-2 at left)
- Order No. **MDI-12A**

CYLINDER HEAD
REBUILDING
CLEANING,
ASSEMBLY & SAFETY
SHORT BLOCK
REBUILDING
CRANKSHAFT/
GRINDING
MISCELLANEOUS
TOOLING
BRAKE SERVICE
MEASURING
TOOLS
V-TWIN & METRIC
HARD PARTS

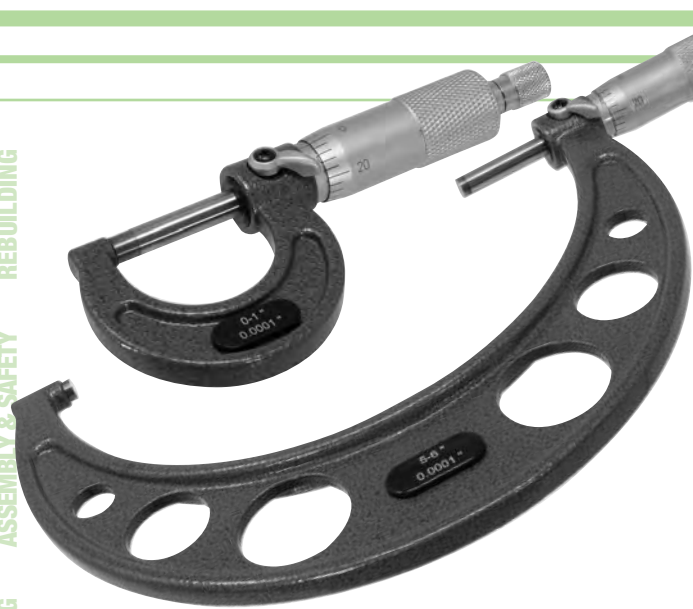

Premium Micrometers

- Precision ground carbide anvil parallel to within .0001"
- .0001" graduations
- Set includes wood storage case

Description	Range	Order No.	Incl.
Micrometer Set	(wood storage case)	EMS-06	▼
Individual Micrometers	0"-1" (no standard)	EMIC-01	x
	1"-2"	EMIC-12	x
Each Micrometer	2"-3"	EMIC-23	x
includes a Standard,	3"-4"	EMIC-34	x
Spanner Wrench & Case	4"-5"	EMIC-45	x
(except EMIC-01)	5"-6"	EMIC-56	x

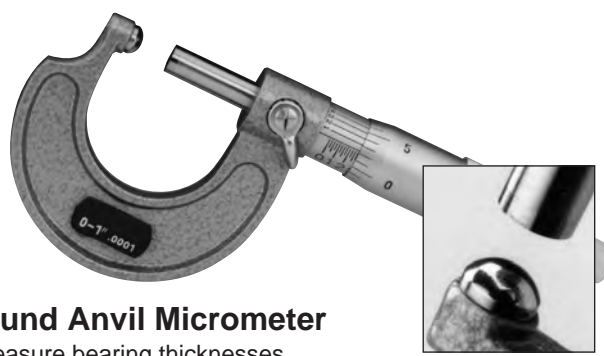

Round Anvil Micrometer

- Measure bearing thicknesses
- Ratchet spindle • 0-1" range • Precise to .0001"
- Order No **MIC-01-B**

Checking Standards

- Use to set up dial indicators in special application gauging and to check micrometer accuracy
- Made of hardened, ground and lapped tool steel
- Meet or exceed federal accuracy specifications



Length	Order No.
1"	MCS-1
2"	MCS-2
3"	MCS-3

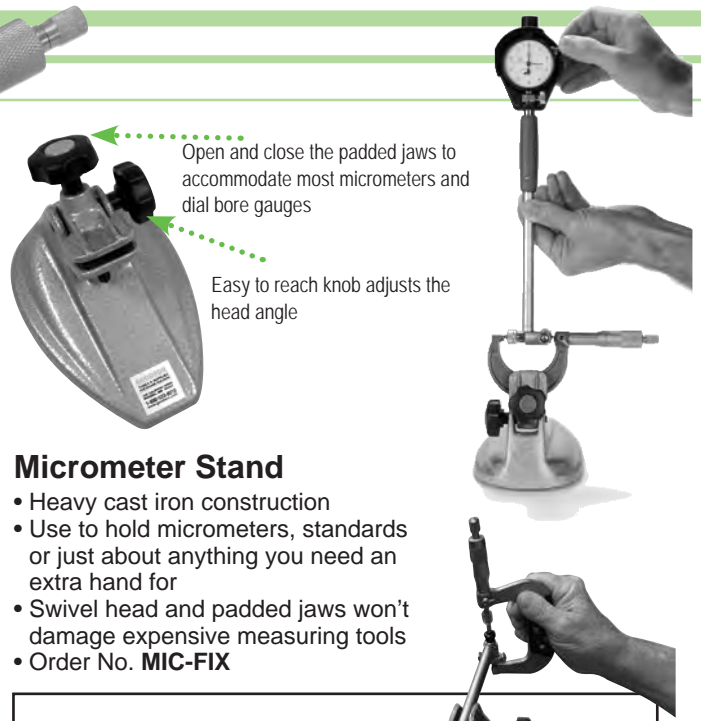

Open and close the padded jaws to accommodate most micrometers and dial bore gauges

Easy to reach knob adjusts the head angle

Micrometer Stand

- Heavy cast iron construction
- Use to hold micrometers, standards or just about anything you need an extra hand for
- Swivel head and padded jaws won't damage expensive measuring tools
- Order No. **MIC-FIX**

Use a Micrometer Stand When Setting Your Dial Bore Gauge

Read more about it on our blog. Scan the code with your smart phone or other smart device for quick access.



Use with Goodson Dial Indicators: EDI-0005, EDI-1 and MDI-12 (page 127)

Universal Magnetic Base Holders

- Fit any type of dial indicator with lug back
- Magnetic base features an on-off switch with magnetic pull of 110 pounds
- 5/8" diameter 7 1/4" high vertical column
- 3.45" x 1.97" x 2.187" base
- Available with or without fine adjustment feature

Description	Order No.
Universal Holder	MBR-1
With Fine Adjustment	MBR-1F

V-Twin On-the-Engine Valve Spring Compressor

Replace broken valve springs, install high performance valve springs, remove and replace valve guide seals all without disassembling the bike – just remove the gas tank and get to work. Use on Sportster, Evolution, Twin-Cam and most aftermarket V-Twins. Kit includes valve spring compressor, adaptor for compressing beehive springs, valve seal driver/installer and head pressurizing hose. Order No. **CF-HDIF**

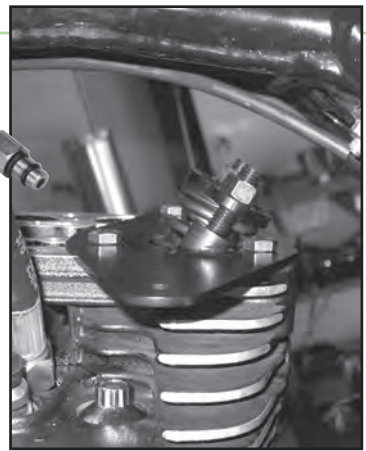

Pan/Shovel Spring Seat Cutting Tool

- Convert Pan & early Shovel to late style Shovel easily to attain higher lift
- Spacer stops the cutter at the correct height for uniform spring spacing
- Use with lower spring collars or stock late style lower spring collars (1980-1984) • OD: 1.680" • ID: 0.750"



Description	Order No.
Spring Seat Cutting Tool	VSS-1680HD
.375" Spring Pad Pilot	VP-375

Guide Driver for Reduced Diameter Top Valve Guides

The guide top fits into the groove between the driver and the bushing to center and drive the guide into place. Puts pressure on the step top of the guide, not the seal area. Required for installing 20-2120 & 20-2130 series guides on page 134. Order No. **VGD-315420**



Keeper Installation Tools

- Spring-loaded plunger
- For single & multi-groove keepers
- Reaches keeper grooves located farther from the valve tip • Ideal for use with **CF-500** (p. 43) or **PSB-5000** (p. 42)

Size	Order No.
5mm / .2031"	VKI-5
6mm / .2344"	VKI-6
7mm / .2812"	VKI-7
8mm / .3125"	VKI-8
Replacement Rubber Sleeve	VKI-56

One of the handiest keeper tools you'll ever find!

Keeper Magnet

- 6⁵/₁₆" long holder fits easily into deep bores
- Powerful .170" diameter earth magnet holds keepers securely when removing or installing
- Order No. **VKM-17**

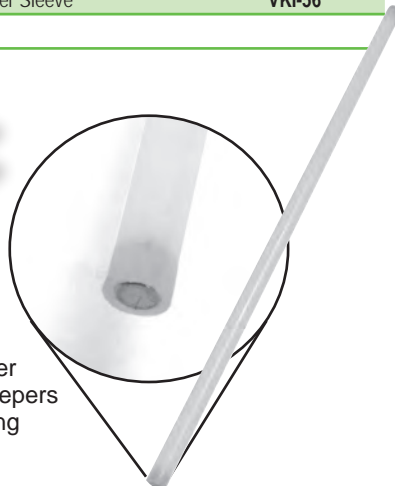

.421" Valve Seal Cutter

- Evo/Twin Cam
- Will shorten and re-chamfer the guide top, increasing seal-to-retainer clearance for higher lift camshafts
- Can also be used to modify .530" guides to .421" guides
- Guide OD: .421" • Pilot Size: .312"
- Use with 71010 seal (page 133)
- Order No. **VSC-420312**



Universal Seal Pliers

- Works on OHC and in-line engines with recessed springs
- Long, serrated jaws reach into confined areas and grip seals firmly
- Heat-treated steel with easy-grip handles
- Order No. **VSP-823**



CYLINDER HEAD REBUILDING ASSEMBLY & SAFETY CLEANING SHORT BLOCK REBUILDING FLYWHEEL GRINDING CRANKSHAFT/ MISCELLANEOUS TOOLS & SUPPLIES BRAKE SERVICE TOOLS MEASURING TOOLS V-TWIN & METRIC HARD PARTS

CYLINDER HEAD REBUILDING
CLEANING, ASSEMBLY & SAFETY
SHORT BLOCK REBUILDING
CRANKSHAFT/ FLYWHEEL GRINDING
MISCELLANEOUS TOOLS & SUPPLIES
BRAKE SERVICE TOOLING
MEASURING TOOLS
V-TWIN & METRIC PARTS



.415" Lift Panhead™
1948 to 1965
Valve Spring Kit for 3/8" Valve Stems

- OE Replacement
- Fits Intake Valve 20-4257 and Exhaust Valve 20-4195
- Heat-treated and shot peened for long life • Kits include 4 Retainers, 4 Springs, 4 Keepers & 4 Base Washers

Max Lift	Installed Height	Seat Pressure	Open Pressure	@ Lift	Order No.
.415"	1.375"	129 lbs.	272 lbs.	.415"	20-20430

.600" Lift Shovelhead™
1966 to 1977

Valve Spring Kit For 3/8" Valve Stems

- Lightweight Racing Kits include 4 Retainers, 4 Springs, 4 Keepers and 4 Base Washers • Lightweight, hard anodized 7075T-6 Retainers offset .070" for taller installed height • Base Washers counter-bored for a .665" OD seal
- Use with Intake Valve 20-4194 & Exhaust Valve 20-4195

Max Lift	Installed Height	Seat Pressure	Open Pressure	@ Lift	Order No.
.600"	1.510"	150 lbs.	385 lbs.	.600"	20-2110

.600" Lift Evolution™
1984 to 1999
Valve Spring Kit For 5/16" Valve Stems

- Heat-treated and shot peened for long life
- Lightweight Racing Kits include 4 Retainers, 4 Springs, 4 Keepers & 4 Base Washers
- Use with Intake Valve 20-4171 & Exhaust Valve 20-4170

Max Lift	Installed Height	Seat Pressure	Open Pressure	@ Lift	Order No.
.600"	1.810"	163 lbs.	361 lbs.	.600"	20-20132



.600" Lift Shovelhead™
1966 to 1977

Valve Spring Kit For 3/8" Valve Stems

- Springs heat-treated and shot peened for long life
- Lightweight Racing Kits include 4 Steel Retainers, 4 Springs, 4 Keepers and 4 Base Washers
- Use with Intake Valve 20-4194 & Exhaust Valve 20-4195

Max Lift	Installed Height	Seat Pressure	Open Pressure	@ Lift	Order No.
.600"	1.510"	150 lbs.	385 lbs.	.600"	20-20450



.655" Lift Evolution™
1984 to 1999
Valve Spring Kit For 5/16" Valve Stems

- Springs heat-treated and shot peened for long life
- Lightweight Racing Kits include 4 Retainers, 4 Springs, 4 Keepers and 4 Base Washers
- Use with Intake Valve 20-4171 & Exhaust Valve 20-4170

Max Lift	Installed Height	Seat Pressure	Open Pressure	@ Lift	Order No.
.655"	1.860"	190 lbs.	465 lbs.	.655"	20-20081



.415" Lift Shovelhead™
1966 to 1977
Valve Spring Kit For 3/8" Valve Stems

- Springs heat-treated and shot peened for long life
- OE Replacement Kit includes 4 Steel Retainers, 4 Springs, 4 Keepers and 4 Base Washers
- Use with Intake Valve 20-4194 & Exhaust Valve 20-4195

Max Lift	Installed Height	Seat Pressure	Open Pressure	@ Lift	Order No.
.415"	1.375"	129 lbs.	272 lbs.	.415"	20-20435



Ensure Your Valve Springs Are Set Correctly with a Valve Spring Tester from Goodson

See page 41



Compression Release Valves

- 2 per pack
- 10 x 1.0mm thread
- High temperature resistant knobs
- Shorter thread section makes installation easier with less drilling than required with OE-style



Application	Length	Thread	Order No.
Evolution	1.400"	.350"L	20-21250
Twin Cam	1.730"	.350"L	20-21255
OE Replacement	1.750"	.500"L	20-21260



.610" Max Lift Beehive Valve Spring Set for 5/16" Valves

- Advanced spring design with special attention to cam and spring harmonics, stress, mass and operating RPM
- Premium grade, super clean ground chrome silicon wire
- Kits include 4 Retainers, 4 Springs, 4 Keepers and 4 Base Washers • Supersedes HVS-6000S

Max Lift	Installed Height	Seat Pressure	Open Pressure	@ Lift	Order No.
.610"	1.860"	175 lbs.	400 lbs.	.610"	20-21300

.660" Max Lift Beehive Valve Spring Sets for 5/16" Valves

- 9° taper • Advanced spring design with special attention to cam and spring harmonics, stress, mass & operating RPM
- Premium grade, super clean ground chrome silicon wire
- Kits include 4 Retainers, 4 Springs, 4 Keepers and 4 Base Washers • Supersedes HVS-6500S

Max Lift	Installed Height	Seat Pressure	Open Pressure	@ Lift	Order No.
.660"	1.860"	178 lbs.	371 lbs.	.660"	20-21500

.610" Max Lift Beehive Valve Spring Sets for 7mm Valves

- Advanced spring design
- Premium grade, super clean ground chrome silicon wire
- Kits include 4 Retainers, 4 Springs, 4 Keepers 4 Viton Seals and 4 Base Washers • Supersedes HVS-6000-7SG

Max Lift	Installed Height	Seat Pressure	Open Pressure	@ Lift	Order No.
.610"	1.860"	175 lbs.	400 lbs.	.610"	20-21400

.660" Max Lift Beehive Valve Spring Sets for 7mm Valves

- 9° taper
- Advanced spring design
- Premium grade, super clean ground chrome silicon wire
- Kits include 4 Retainers, 4 Springs, 4 Keepers, 4 Viton Seals and 4 Base Washers • Supersedes HVS-6500-7SG

Max Lift	Installed Height	Seat Pressure	Open Pressure	@ Lift	Order No.
.660"	1.860"	178 lbs.	371 lbs.	.660"	20-21550

Evolution™ (04-99), Evo Sportster™ 883cc (96-03) XL™ 1100cc (86-87), Evo Sportster™ 1200cc (88-20), Twin Cam™ 88" (99-04) & Buell™ XB9-XB-12 (03-10)



Lightweight Racing Dual Spring Kits

- Exact match for installation heights and spring pressures
- Retainers designed for optimum rocker cover clearance
- Includes 4 heavy-duty 9° high-temperature steel keepers, 4 springs, 4 retainers and 4 base washers

Max Lift	Installed Height	Seat Pressure	Open Pressure	@ Lift	Order No.
Fit 5/16" Valve Stems High Temperature Steel Retainers and BaseWashers Seals Sold Separately					
.650"	1.860"	185 lbs.	440 lbs.	.650"	20-21650
.675"	1.860"	185 lbs.	450 lbs.	.675"	20-21600
Fit 7mm Valve Stems High Temperature Steel Retainers and BaseWashers Seals Included					
.650"	1.860"	185 lbs.	440 lbs.	.650"	20-23500
.675"	1.860"	185 lbs.	450 lbs.	.675"	20-23600
Fit 7mm Valve Stems Titanium Retainers and High Temperature Steel BaseWashers Seals Included					
.650"	1.860"	185 lbs.	440 lbs.	.650"	20-23550
.675"	1.860"	185 lbs.	450 lbs.	.675"	20-23650

CYLINDER HEAD
REBUILDING
CLEANING, ASSEMBLY & SAFETY
SHORT BLOCK
REBUILDING
FLYWHEEL GRINDING
CRANKSHAFT/
MISCELLANEOUS
TOOLS & SUPPLIES
BRAKE SERVICE
TOOLING
MEASURING
TOOLS
V-TWIN & METRIC
HARD PARTS

... another satisfied customer

"No complaints! Been in this business 40 years. Goodson is one of the best companies I've dealt with."

- Joe James, Brighton, CT - Goodson Customer since 2002

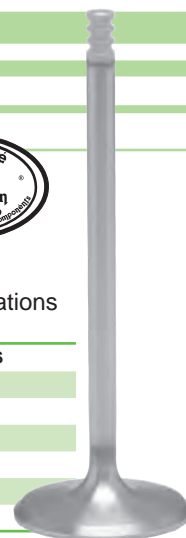

White Diamond® Hard Chrome Replacement Valves for Milwaukee-Eight™ Heads

- 1-piece forged with White Diamond® hard chrome stems for impervious wear resistance
- Inconel® 751 exhaust valves designed to outperform in the most extreme forced induction or racing applications
- Flow bench tested to optimize intake and exhaust profiles

Type	Head Dia.	Stem Dia.	Radius	Angle	OAL	Order No.	Material	Supersedes
Intake	1.614" (41.00mm)	0.2347"	0.235"	15°	4.035"	20-21060H	Chrome	-----
Intake	1.630" (41.40mm)	0.2347"	0.235"	10°	4.055"	20-21009H	Chrome	20-21009
Intake	1.654" (42.01mm)	0.2347"	0.235"	15°	4.032"	20-21061H	Chrome	20-21014
Exhaust	1.264" (32.11mm)	0.2342"	0.460"	24°	4.050"	20-21016H	Chrome	20-21016
Exhaust	1.284" (32.61mm)	0.2342"	0.460"	24°	4.050"	20-21017H	Chrome	20-21017
Exhaust	1.299" (32.99mm)	0.2342"	0.395"	0°	4.055"	20-21062K	Chrome	-----

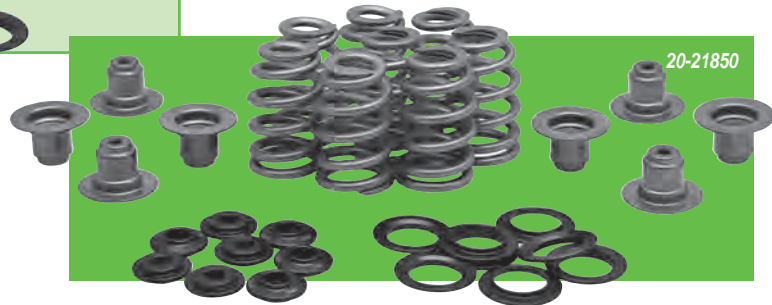

Milwaukee-Eight™ Beehive Spring Kits

- Includes 8 progressively wound ovate wire Beehive Springs, 8 Retainers, 8 Tophat Seals and 8 Spring Bases

Max Lift	Installed Height	Seat Pressure	Open Pressure	@ Lift	Order No.
Titanium Retainers					
.625"	1.500"	85 lbs.	280 lbs.	.625"	20-21800
Heat Treated Steel Retainers					
.625"	1.500"	85 lbs.	280 lbs.	.625"	20-21850

Milwaukee-Eight™ Beehive Valve Spring Kits

- Advanced spring design with special attention to cam and spring harmonics, stress, mass and operating RPM
- Premium-grade, super clean ground chrome silicon wire • Heat-treated and shot peened for long life

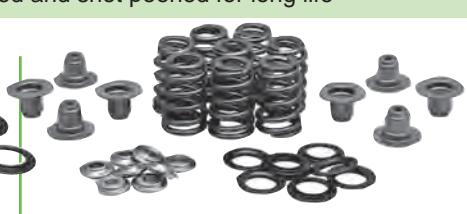
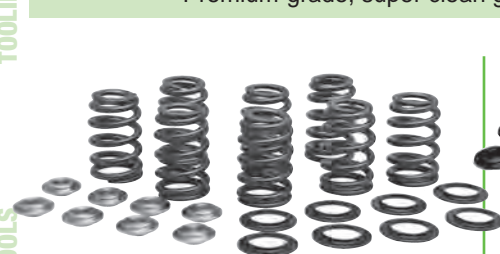

.465" Max Lift Beehive Valve Spring Kit With Titanium Retainers

- Includes 8 retainers, 8 springs and 8 base washers
- Installed Height: 1.410"
- Seat Pressure: 80 lbs.
- Open Pressure: 212 lbs. at .465"
- Order No. **20-21000**

.465" Max Lift Beehive Valve Spring Kit With Heat Treated Steel Retainers

- Includes 8 retainers, 8 springs and 8 base washers
- Installed Height: 1.410"
- Seat Pressure: 80 lbs.
- Open Pressure: 212 lbs. at .465"
- Order No. **20-21050**

.550" Max Lift Beehive Valve Spring Kit With Titanium Retainers

- Supersedes #20-21200
- Includes 8 retainers, springs, base washers and viton tophat seals
- Installed Height: 1.550"
- Seat Pressure: 85 lbs.
- Open Pressure: 257 lbs. at .550"
- Order No. **20-21205**

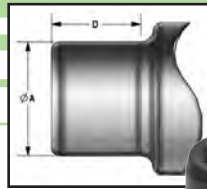

Solid Viton Seals With Metal Jacket & Choker Spring

• 16 Per Package

Stem Dia.	OAL	Seal OD	A	D	Order No.	Supersedes
7.0mm	0.510"	0.665"	0.560"	0.375"	71028	HVS-7MM
.312"	0.412"	0.566"	0.420"	0.275"	71010	HVS-421
.312"	0.514"	0.671"	0.530"	0.330"	71045	HVS-531
.375"	0.516"	0.661"	0.562"	0.375"	71011	—

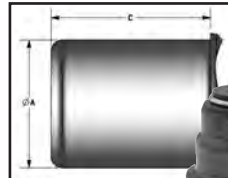

Solid Viton Seals With Metal Jacket & Integral Spring Base

• 16 Per Package

• Spring Shoulder Diameter: 0.970"

Stem Dia.	OAL	Seal OD	A	C	Order No.	Supersedes
7.0mm	0.974"	1.457"	0.560"	0.700"	71030	HV-7MMOE



Milwaukee-Eight™ Tophat Valve Seal

• 16 Per Package

Stem Dia.	OAL	Seal OD	A	C	Order No.	Supersedes
6.0mm	0.712"	1.170"	—	—	71046-16	—

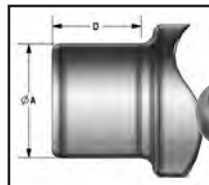

OE Style Seals Solid Teflon With Metal Jacket

16 Per Package

Stem Dia.	OAL	Seal OD	A	D	Order No.	Supersedes
.312"	0.385"	0.565"	0.420"	0.315"	71032	HSS-420
.312"	0.375"	0.630"	0.530"	0.295"	71033	HSS-530312
.343"	0.375"	0.630"	0.530"	0.365"	71034	HSS-530343
.375"	0.375"	0.660"	0.562"	0.315"	71035	HSS-562
.375"	0.400"	0.720"	0.625"	0.310"	71036	HSS-625

Need something not listed here?

We can order just about anything in the Kibblewhite catalog for you.

Call us at 1-800-533-8010 for more information.



Valve Seat Inserts

- For Harley-Davidson®
- Easy to machine
- Effectively dissipate heat for consistent valve sealing
- Hardness increases during engine break-in
- Radiused for easy installation



Replacement Valve Seats For Shovel Head 1200 & 1340

Application	OD	ID	Thick	Order No.	Supersedes
Exhaust	1.944"	1.575"	.400"	10-HC493	HVS-1944
Intake	2.135"	1.750"	.400"	10-HC542	HVS-2135

Overize Seats For Shovel, Evolution, Twin Cam & M8 – machining required

	OD	ID	Thick	Order No.	Supersedes
Fits M8	1.630"	1.180"	.385"	10-HC414	HVS-1630
	1.757"	1.410"	.430"	10-HC447	HVS-1757
	1.882"	1.520"	.410"	10-HC478	HVS-1882
	2.008"	1.610"	.440"	10-HC510	HVS-2008
	2.040"	1.700"	.425"	10-HC518	HVS-2040
	2.070"	1.610"	.460"	10-HC526	HVS-2070
	2.132"	1.800"	.460"	10-HC541	HVS-2132
	2.163"	1.750"	.455"	10-HC549	HVS-2163

For Iron Head Sportster

Application	OD	ID	Thick	Order No.	Supersedes
Exhaust	1.757"	1.371"	.315"	10-HC446	HVS-1757S
Intake	2.068"	1.750"	.315"	10-HC525	HVS-2068

Universal Repair Seat

	OD	ID	Thick	Order No.	Supersedes
Powdered	1.339"	1.024"	.375"	10-SC340	MVS-42
Metal	1.693"	1.299"	.434"	10-SC430	MVS-58
	1.819"	1.375"	.450"	10-HC462	HVS-1820
	1.945"	1.500"	.450"	10-HC494	HVS-1945
	2.257"	1.870"	.450"	10-HC573	HVS-2257

Nickel Chrome Valve Seats on Page 16

tech tips When installing seats preheat head to 400° and freeze the seat for easier installation. Press fit .006" to .008".



6061-T6 Aluminum Seal Drivers

These installation tools for OE style seals are manufactured from high strength 6061-T6 Aluminum for increased durability when compared to plastic installers.

Application	Color	Fits Seal Up To	Order No.
Evolution	Red	0.575"	20-20830
Pan/Shovelhead 74"	Black	0.673"	20-20833
Ironhead Sportster	White	0.638"	20-20832
Shovelhead 80"	Blue	0.758"	20-20831



CYLINDER HEAD REBUILDING & SAFETY
 SHORT BLOCK REBUILDING
 CRANKSHAFT/ FLYWHEEL GRINDING
 MISCELLANEOUS TOOLS & SUPPLIES
 BRAKE SERVICE TOOLS
 MEASURING TOOLS
 V-TWIN & METRIC HARD PARTS

... another satisfied customer

"Thank you for a good supply of tooling. Everyone there is very helpful. You don't always find that anymore."
 - John Bursick, Harts Machine Service, Cecil, OH, Goodson Customer since 1997

CYLINDER HEAD REBUILDING
 CLEANING, ASSEMBLY & SAFETY
 SHORT BLOCK REBUILDING
 CRANKSHAFT/ FLYWHEEL GRINDING
 MISCELLANEOUS TOOLS & SUPPLIES
 BRAKE SERVICE TOOLING
 MEASURING TOOLS
 V-TWIN & METRIC HARD PARTS

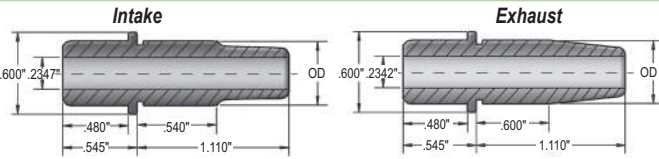

Milwaukee-Eight™ Valve Guides

• Use with 6mm seals (71046 or OE)

Intake				Manganese Bronze		Cast Iron	
OD	ID	OAL	Size	Part No.	Part No.	Supersedes	
.4750"	.2347"	1.655"	Std.	20-21020M	—	—	—
.4760"			+ .001"	20-21021M	—	—	—
.4770"			+ .002"	20-21022M	20-21022C	—	—
.4850"			+ .010"	20-21029M	20-21029C	—	—

Exhaust				Manganese Bronze		Cast Iron	
OD	ID	OAL	Size	Part No.	Part No.	Supersedes	
.4750"	.2342"	1.655"	Std.	20-21030M	20-21030C	—	—
.4760"			+ .001"	20-21031M	20-21031C	—	—
.4770"			+ .002"	20-21032M	20-21032C	—	—
.4850"			+ .010"	20-21039M	20-21039C	—	—

MSRP / Jobber

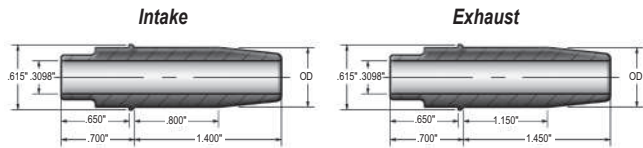

Evolution, Twin-Cam & Evo Sportster With 5/16" Valves (.420" Guide Top)

• Use with 71010 Viton Seals or 71032 OE Style Seals

Intake				Manganese Bronze		Cast Iron	
OD	ID	OAL	Size	Part No.	Part No.	Supersedes	
.5620"	.3098"	2.100"	Std.	20-2120M	20-2120C	—	—
.5630"			+ .001"	20-2121M	20-2121C	HVG-5600S	—
.5640"			+ .002"	20-2122M	20-2122C	HVG-5601S	—
.5720"			+ .010"	20-2129M	—	—	—

Exhaust				Manganese Bronze		Cast Iron	
OD	ID	OAL	Size	Part No.	Part No.	Supersedes	
.5620"	.3098"	2.150"	Std.	20-2130M	20-2130C	—	—
.5630"			+ .001"	20-2131M	20-2131C	HVG-5700S	—
.5640"			+ .002"	20-2132M	20-2132C	HVG-5701S	—
.5720"			+ .010"	20-2139M	—	—	—

MSRP / Jobber

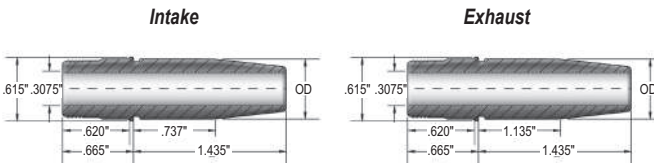

Evolution, Twin-Cam & Evo Sportster With 5/16" Valves (.530" Top Guides)

• Use with 71045 Viton Seals

Intake				Manganese Bronze		Cast Iron	
OD	ID	OAL	Size	Part No.	Part No.	Supersedes	
.5625"	.3075"	2.100"	Std.	20-20860M	—	HVG-5600	—
.5635"			+ .001"	20-20861M	—	HVG-5601	—
.5645"			+ .002"	20-20862M	—	HVG-5602	—

Exhaust				Manganese Bronze		Cast Iron	
OD	ID	OAL	Size	Part No.	Part No.	Supersedes	
.5625"	.3096"	2.100"	Std.	20-20870M	—	HVG-5700	—
.5635"			+ .001"	20-20871M	—	HVG-5701	—
.5645"			+ .002"	20-20872M	—	HVG-5702	—
.5725"			+ .010"	20-20879M	—	—	—

MSRP / Jobber

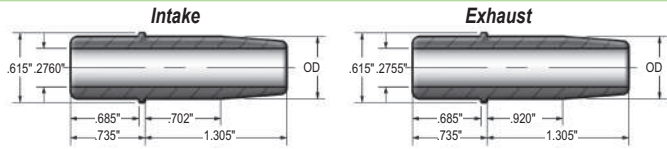

Twin Cam & Evo Sportster w/ 7mm Valves

• Use with 71028 (0.562") Viton Seals

Intake				Manganese Bronze		Cast Iron	
OD	ID	OAL	Size	Part No.	Part No.	Supersedes	
.5625"	.2760"	2.040"	Std.	20-20690M	—	HVG-6600	—
.5635"			+ .001"	20-20691M	—	HVG-6601	—
.5645"			+ .002"	20-20692M	—	HVG-6602	—
.5725"			+ .010"	20-20699M	—	—	—

Exhaust				Manganese Bronze		Cast Iron	
OD	ID	OAL	Size	Part No.	Part No.	Supersedes	
.5620"	.2755"	2.040"	Std.	20-20700M	—	HVG-6700	—
.5630"			+ .001"	20-20701M	—	HVG-6701	—
.5640"			+ .002"	20-20702M	—	HVG-6702	—
.5720"			+ .010"	20-20709M	—	—	—

MSRP / Jobber

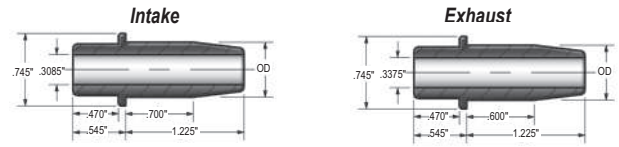

Sportster (1970-1983)

• Use with 71033 (intake) & 71034 (exhaust) OE-Style Seals

Intake				Manganese Bronze		Cast Iron	
OD	ID	OAL	Size	Part No.	Part No.	Supersedes	
.5650"	.3085"	1.770"	Std.	—	20-2320C	HVG-5100C	—
.5660"			+ .001"	—	20-2321C	HVG-5101C	—
.5670"			+ .002"	—	20-2322C	HVG-5102C	—

Exhaust				Manganese Bronze		Cast Iron	
OD	ID	OAL	Size	Part No.	Part No.	Supersedes	
.5650"	.3375"	1.770"	Std.	—	20-2330C	HVG-5200C	—
.5660"			+ .001"	—	20-2331C	HVG-5201C	—
.5670"			+ .002"	—	20-2332C	HVG-5202C	—

MSRP / Jobber

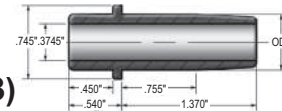

Shovel Head 80" (78-83)

• Use with 71036 OE Style Seals

Intake or Exhaust				Manganese Bronze		Cast Iron	
OD	ID	OAL	Size	Part No.	Part No.	Supersedes	
.6250"	.3745"	1.910"	Std.	20-2050M	20-2050C	HVG-5400	—
.6260"			+ .001"	20-2051M	20-2051C	HVG-5401	—
.6270"			+ .002"	20-2052M	20-2052C	HVG-5402	—

MSRP / Jobber

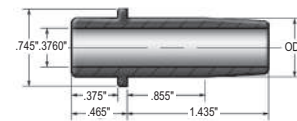

Shovel & Pan Heads

• Use with 71011 Viton seals or 71035 OE Style Seals

Intake or Exhaust				Manganese Bronze		Cast Iron	
OD	ID	OAL	Size	Part No.	Part No.	Supersedes	
.5650"	.3760"	1.900"	Std.	20-2020M	20-2020C	—	—
.5660"			+ .001"	20-2021M	20-2021C	—	—
.5670"			+ .002"	20-2022M	20-2022C	—	—
.5680"			+ .003"	20-2023M	20-2023C	—	—
.5750"			+ .010"	20-2029M	20-2029C	—	—

MSRP / Jobber

High Performance Valves



tech tips Always check and confirm running clearances when installing new valves.
from the techxperts™

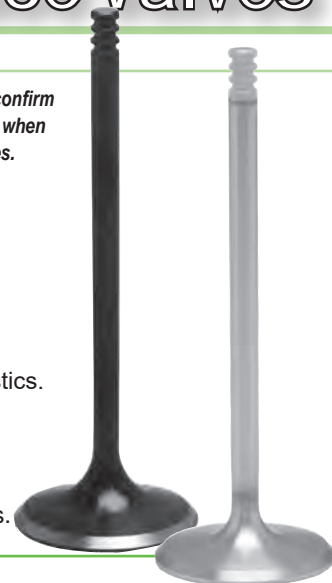

Black Diamond™ & White Diamond® Valves for Harley-Davidson® Engines

- **Light and strong with optimum airflow** A combination of stress analysis and flow bench testing for optimally balanced valve mass, strength and airflow characteristics.
- **Black Diamond™ Valves** One piece forged stainless steel valves impregnated by a special German process to improve wear properties and reduce friction. Provides resistance to corrosion and superior wear.
- **Chrome Diamond® Valves** One piece forged with White Diamond® hard chrome stems. Inconel® 751 exhaust valves are designed to perform even in the most extreme conditions. Flow bench tested to optimize intake and exhaust profiles.

Application	Type	Head Diameter	Stem Diameter	Tulip Radius	Tulip Angle	Overall Length	Order No.	Supersedes
Milwaukee-Eight	Intake	1.571" (39.90mm)	0.2347"	0.235"	10°	4.015"	20-21012H	20-21012
	Intake	1.614" (41.00mm)	0.2347"	0.235"	15°	4.035"	20-21060H	-----
	Intake	1.630" (41.40mm)	0.2347"	0.235"	10°	4.055"	20-21009H	20-21009
	Intake	1.654" (42.01mm)	0.2347"	0.235"	15°	4.032"	20-21061H	20-21014
	Exhaust	1.264" (32.11mm)	0.2342"	0.460"	24°	4.050"	20-21016H	20-21016
	Exhaust	1.284" (32.61mm)	0.2342"	0.460"	24°	4.050"	20-21017H	20-21017
Pan Head 1948-1965 Black Diamond™	Intake	1.750" (44.45mm)	0.3765"	0.234"	23°	3.800"	20-4257	-----
	Exhaust	1.750" (44.45mm)	0.3760"	0.234"	29°	3.820"	20-4195	-----
Sportster 1970-1983	Intake	1.935" (49.15mm)	0.3090"	0.256"	23°	3.620"	20-4196	HEV-5
	Intake	1.950" (49.53mm)	0.3090"	0.256"	23°	3.690"	20-4167	-----
	Exhaust	1.570" (39.88mm)	0.3384"	0.236"	29°	3.512"	20-4197	HEV-3
Shovelhead 74" & 80" 1966-1983	Intake	1.950" (49.53mm)	0.3765"	0.234"	23°	3.885"	20-4194	HEV-9
	Intake	2.000" (50.80mm)	0.3765"	0.234"	23°	3.885"	20-4256	-----
Shovelhead 74" & 80" 1966-1983	Exhaust	1.750" (44.45mm)	0.3760"	0.234"	29°	3.810"	20-4195	HEV-7
	Intake	1.950" (49.53mm)	0.3780"	0.234"	23°	3.885"	20-4294	-----
66-83 "Fat Stem"	Exhaust	1.750" (44.45mm)	0.3775"	0.234"	29°	3.810"	20-4295	-----
Evolution 1984-1999	Intake	1.840" (46.74mm)	0.3100"	0.236"	23°	4.445"	20-4171	-----
	Intake	1.940" (49.28mm)	0.3108"	0.675"	25°	4.440"	20-20910	HBV-1940
	Intake	1.900" (48.26mm)	0.3108"	0.675"	25°	4.440"	20-20915	HBV-1900
	Intake (Racing)	1.900" (48.26mm)	0.3100"	0.344"	28°	4.420"	20-4171R	HBV-1900S
	Intake	2.150" (54.61mm)	0.3108"	0.550"	24°	4.480"	20-20900	HCV-2150
	Exhaust	1.615" (41.02mm)	0.3096"	0.236"	29°	4.525"	20-4170	HEV-10
	Exhaust (Racing)	1.630" (41.40mm)	0.3096"	0.500"	40°	4.525"	20-4170R	-----
	Exhaust	1.650" (41.91mm)	0.3106"	0.750"	25°	4.515"	20-20920	HBV-1650
	Exhaust	1.610" (40.89mm)	0.3106"	0.750"	25°	4.510"	20-20925	HBV-1610D
	Exhaust	1.585" (40.26mm)	0.3106"	0.750"	25°	4.505"	20-20930	HBV-1585
Evo Sportster 883 to 1200cc	Intake	1.715" (43.56mm)	0.3100"	0.236"	23°	4.550"	20-2010	HBV-1720
	Exhaust	1.480" (37.59mm)	0.3096"	0.500"	40°	4.625"	20-2012	-----
Twin Cam 88"-103" 2005-2017	Intake	1.805" (45.85mm)	0.2760"	0.413"	1.700°R	4.420"	20-20322	HBV-1810-7TG
	Intake	1.900" (48.26mm)	0.2760"	0.344"	28°	4.420"	20-20323R	-----
	Exhaust	1.575" (40.00mm)	0.2755"	0.354"	22°	4.520"	20-20325	-----
	Exhaust	1.630" (41.40mm)	0.2755"	0.500"	34°	4.520"	20-20326R	-----
Buell® XB9™ 2003-2007	Intake	1.805" (45.85mm)	0.2760"	0.344"	28°	4.525"	20-20260	-----
	Intake	1.900" (48.26mm)	0.2760"	0.344"	28°	4.500"	20-20262	-----
Twin Cam, Sportster & Buell®	Intake	1.980" (50.29mm)	0.2757"	0.290"	23°	4.455"	20-20935	HBV-1980-7TG
	Intake	1.900" (48.26mm)	0.2757"	0.475"	24°	4.445"	20-20940	HBV-1900-7TG
Triple Groove	Exhaust	1.610" (40.89mm)	0.2755"	0.595"	25°	4.545"	20-20945	HBV-1610-7TG
	Exhaust	1.575" (40.05mm)	0.2755"	0.595"	25°	4.560"	20-20950	HBV-1575-7TG
Evo, Big Twin & Twin Cam	Intake	2.020" (51.31mm)	0.3108"	0.670"	25°	4.440"	20-20990	HBV-2020A
	Exhaust	1.700" (43.18mm)	0.3106"	0.600"	25°	4.535"	20-20960	HBV-1700A
S&S®, Screaming Eagle & Ultima®	Intake	2.020" (51.31mm)	0.3108"	0.645"	25°	4.510"	20-20965	HBV-2020S
SE® / JIMS®	Exhaust	1.610" (40.89mm)	0.3106"	0.750"	25°	4.565"	20-20970	HBV-1610S
	Exhaust	2.100" (53.34mm)	0.3108"	0.560"	24°	4.475"	20-20955	HBV-2100
Blank Valves	Black	2.100" (53.34mm)	0.3108"	-----	24°	5.700"	20-20980	HBV-1700BC
	Chrome	2.200" (55.88mm)	0.3108"	-----	25°	5.700"	20-20975	HCV-2200BC
Ready to machine	Black	2.100" (53.34mm)	0.3108"	-----	24°	5.700"	20-20980	HBV-1700BC
Ready to machine	Chrome	2.200" (55.88mm)	0.3108"	-----	25°	5.700"	20-20975	HCV-2200BC

CYLINDER HEAD
REBUILDING
CLEANING,
ASSEMBLY & SAFETY
SHORT BLOCK
REBUILDING
FLYWHEEL GRINDING
CRANKSHAFT/
TOOLS & SUPPLIES
MISCELLANEOUS
BRAKE SERVICE
TOOLING
MEASURING
TOOLS
V-TWIN & METRIC
HARD PARTS

RAPIDEX

A rapid-use index of product categories

Cylinder Head Rebuilding

Pilots.....	3-5
Valve Seat Work.....	6-24
Valve Refacing.....	25-29
Reamers.....	30-31
Valve Guide Resizing.....	32-34
Valve Guide Replacement.....	35-39
Valve Seal Work.....	40
Valve Spring Work.....	41-46
Cylinder Head Resurfacing.....	48-51
Crack Detection & Repair.....	52-55
Porting & Polishing.....	58-60

Cleaning, Assembly & Safety

Parts Storage & Organizers.....	61-63
Parts Baskets.....	63
Wire Wheels & Brushes.....	64-65
Cleaning.....	66-69
Last Blast Paint & Metal Markers.....	70
Assembly Lubes.....	71
Coolants & Lubricants.....	72-74

Index	75-82
Flex-Hones®.....	83

Short Block Rebuilding

Boring Bar Tooling & Supplies.....	84-85
Cylinder Honing.....	86-91
Rod Honing.....	92
Rod & Piston Work.....	93-97
Lifter Bore Tooling.....	99
Camshaft Work.....	100-101

Crankshaft/Flywheel Grinding

Crankshaft Grinding Wheels.....	102-103
Crankshaft Grinding & Polishing.....	105-109
Flywheel Grinding.....	110-113

Miscellaneous Tools

Diamond Dresser Tools.....	114-115
Miscellaneous.....	116

Brake Service Tooling

Brake Tips & Holders.....	117-118
Brake Lathe Silencers.....	119
Brake Lathe Replacement Parts.....	120-122

Measuring Tools

Straight Edges.....	123
Dial Bore Gauges.....	125-126
Calipers & Dial Indicators.....	127
Micrometers.....	129

V-Twin Hard Parts

Valve Springs.....	130-132
Seats & Seat Inserts.....	133
Valve Guides.....	134
Replacement Valves.....	135

© Copyright 2024, Goodson Mfg. Co., Inc. All copy and illustrations are copyrighted. Absolutely no mechanical or electronic reproduction or use of any part is allowed without our prior written permission. Goodson reserves the right to correct printing errors. Prices are subject to change without notice.

RW-GR-CAP
One-Size-Fits-Most
Snap-Back Cap



RW-CC
Goodson
logo on one
side and
"Goodson
Forever" on
the other



CA-100
Modeled by
Tim from
Production

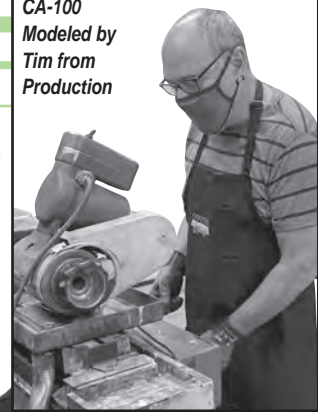

RW-CAP
Flex-Fit Cap with
closed back.
Available in two
sizes —
Small/Medium
and Large/X-Large
Modeled by Dylan from
Production



RW-GTB
Modeled by
Tracy & Craig
from Receiving

RW-GTW
Modeled by
Paige from
Customer
Service

GOODSON Gear

Sport your Goodson gear around the shop, at the track or just out and around!

Description	Color	Sizes	Order No.
Pre-Shrunk Cotton T-Shirts	White	Large	RW-GTW-L
		X-Large	RW-GTW-XL
		XX-Large	RW-GTW-XXL
	Black	Medium	RW-GTB-M
		Large	RW-GTB-L
		X-Large	RW-GTB-XL
		XX-Large	RW-GTB-XXL
Snap Back Cap	Black	adjustable	RW-GR-CAP
Flex-Fit Cap	Black	Small/Medium	RW-CAP-SM
	Black	Large/X-Large	RW-CAP-L
Shop Apron	Black	n/a	CA-100
Can Cooler	Black	n/a	RW-CC



Watch for this symbol throughout the catalog

We know pictures often tell the story better than words so we are making videos for many of the products in the Goodson product line. The symbol above indicates that there is a video available for that product. Where space allows we are including a QR code that will take you directly to the video. All you need to do is point your smartphone camera at the code and the link will open.



Mach-B Grinding Wheel Shaping & Resizing

From routine grinding wheel shaping and sizing to emergency work, ***Mach-B Can Do That!***

Mach-B Grinding Wheel Shaping & Resizing specializes in:

- Custom Grinding Wheel Shaping
- Custom Grinding Wheel Sizing
- Reducing Outside Diameters
- Increasing Inside Diameters
- ANSI Compliant Speed Testing
- Static Balance Testing
- Standard and Custom Profiles
- Grinding Wheel Slotting



Turn to Mach-B and Goodson for Fast Turnaround. Visit www.mach-b.com for more information.



Custom Abrasive Belts

- Any Length (up to 520")
- Any Width (up to 15")*
- Aluminum-Oxide
- Ceramic-Alumina
- Silicon-Carbide
- Zirconia-Alumina
- 36 to 600 Grit*

Abrasive Industrial Supplies Has You Covered!

Abrasive Industrial Supplies (AIS) is a division of Goodson specializing in stock and custom grinding, sanding and polishing belts. We make belts in-house and can make whatever size belt you need.

*Grit & width availability varies by abrasive grain.

Choose from a variety of abrasives in several grits and backings for a wide range of applications.

You can order directly from AIS by calling **1-800-433-8010** or visiting the website; www.abrasiveindustrialsupplies.com OR talk to your Goodson customer service rep.

Now that's ONE STOP SHOPPING!



Abrasive Industrial Supplies
A Division of Goodson Manufacturing



A TYROLUT Company

10
9
8
7
6
5
4
3
2
1

GOODSON

Tools and Supplies for Engine Builders

156 Galewski Drive
Winona, MN 55987

Easy Toll-Free Ordering by Phone
1-800-533-8010

Toll-Free Fax 24-Hours a Day
1-888-466-3909

Order Online!
www.goodson.com

Use this ruler to measure the approximate size of your parts.



fijntechniek fijnaart b.v.

Machines voor motoren revisie,
honen en ultrasoonreinigen

Service makes the difference!

Blaaksedijk 30 | 4793 RN Fijnaart | Nederland
tel. +31 (0)168 46 44 61 info@ftf.nl www.ftfmachines.com

Meet the Goodson Employee Owners

We're here to serve you!

